

CLS : CLOSE LIMIT SWITCH (250VAC 6A)
 OLS : OPEN LIMIT SWITCH (250VAC 6A)
 CTS : CLOSE TORQUE SWITCH (250VAC 6A)
 OTS : OPEN TORQUE SWITCH (250VAC 6A)
 ACLS : AUX. CLOSE LIMIT SWITCH (250VAC 6A)
 AOLS : AUX. OPEN LIMIT SWITCH (250VAC 6A)
 TP : THERMAL PROTECTOR (250VAC 15A)

	CLOSE	OPEN
CLS 1-2		
CLS 1-3		
OLS 1-2		
OLS 1-3		
ACLS 1-2		
ACLS 1-3		
AOLS 1-2		
AOLS 1-3		
CTS 1-3	* CLOSING TORQUE SWITCH INTERRUPTS CONTROL IF MECHANICAL OVERLOAD OCCURS DURING CLOSING CYCLE	
OTS 1-3	* OPENING TORQUE SWITCH INTERRUPTS CONTROL IF MACHANICAL OVERLOAD OCCURS DURING OPENING CYCLE	

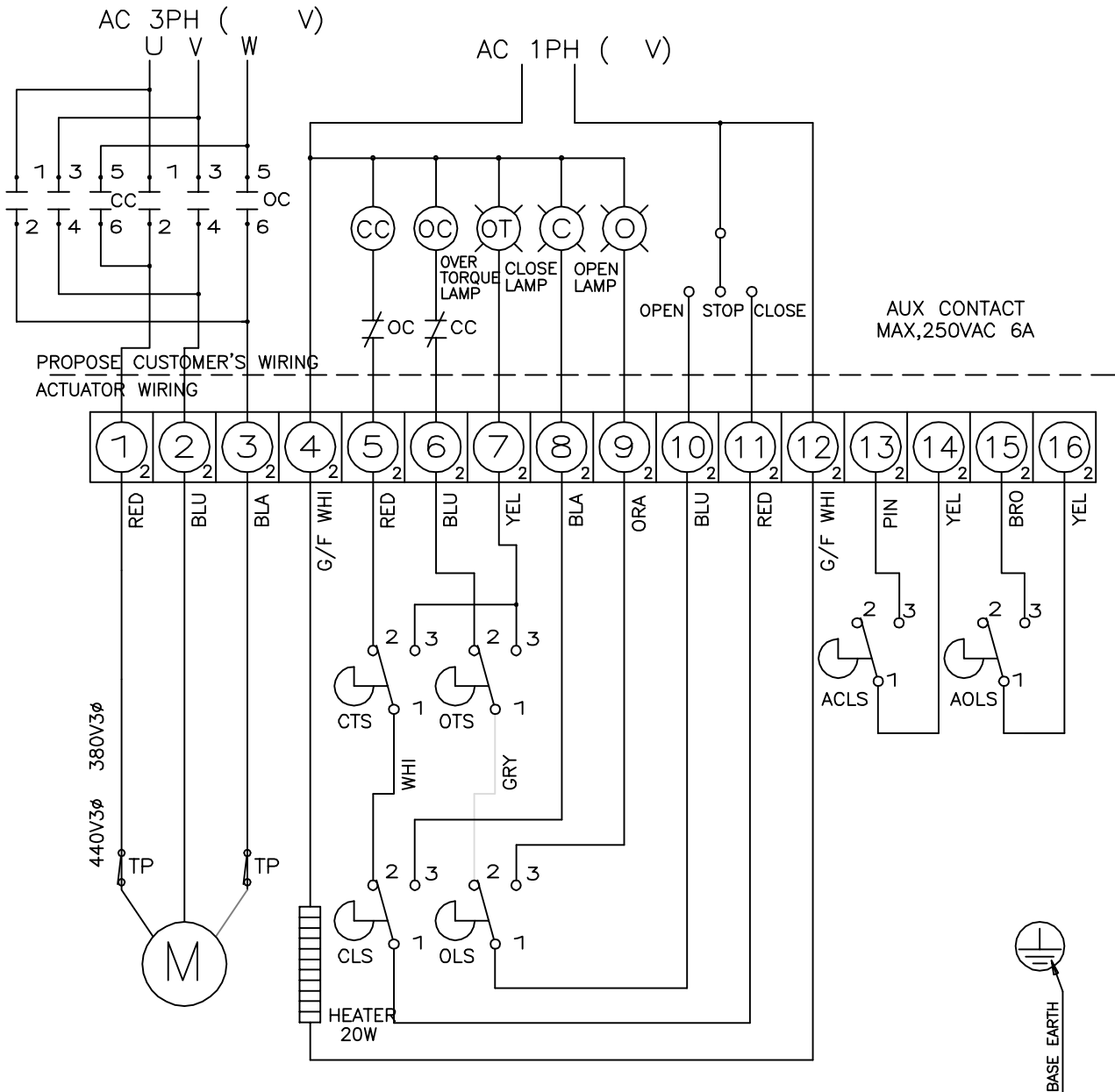

A050	1	A250	1	△					
A038	1	A200	1	SYM	E C N NO	CHANGES	DATE	SIGN	APPD
A028	1	A150	1	DRAW	H,J KWON	PART NAME	3PH WIRING DIAGRAM		
A019	1	A100	1	CHECK			ALS		
A015	1	A080	1	APPD					
APPLICATION		A060	1	DATE	'06.04.10	DWG NO.	NS-32000-D		