



1040 N. Meridian Rd., P.O. Box 1556, Youngstown, Ohio 44501
 Phone: (330) 799-3333 Toll Free: 1-800-677-1799 FAX: (330) 797-3215

www.trumbull-mfg.com

ADJUSTABLE CHAINWHEELS

Ductile Iron
To Operate Overhead Valves From The Floor.

Ductile Iron Chainwheels allow operation of valves in high, hard-to reach locations by means of a slight pull on the sprocket chain. Universal design allows Chainwheel to be clamped to handwheel, or pinned directly to valve stem.

All Chainwheels are furnished with plated steel attachment hardware for clamping to handwheel. When Chainwheel is to be pinned to valve stem, a ductile iron bushing will be provided which can be machined to suit valve stem dimensions. Bushing and Chainwheel will be pre-drilled with pin hole, and supplied with a stainless steel pin for customer mounting to valve stem. Drilling of valve stem by customer. See reverse side for illustration of bushing.

SPECIFICATIONS:

Trumbull Item No. for Chainwheel	Size No.	Diameter of Chainwheel	Boxed Weight	O.D. Range of Handwheels Chainwheel Will Fit	Trumbull Item No. for Galv. Chain	Chain Weight per 100'	Length of Chain Required (2x Drop)
367-1873	TR-0.0	4"	3.0#	2" to 4"	172-1650	10.0#	Plus 1 ft.
367-1874	TR-1.0	6"	5.0#	4-1/4" to 5-3/4"	367-1894	17.5#	Plus 1 ft.
367-1875	TR-1.5	7-1/2"	9.2#	6" to 7-1/2"	367-1894	17.5#	Plus 1 ft.
367-1876	TR-2.0	9"	12.9#	7-3/4" to 9"	367-1894	17.5#	Plus 1-1/2 ft.
367-1877	TR-2.5	12-1/2"	15.7#	9-1/4" to 12-1/2"	367-1895	30.0#	Plus 1-1/2 ft.
367-1878	TR-3.0	15-1/2"	22.0#	12-3/4" to 15-1/2"	367-1895	30.0#	Plus 2 ft.
367-1879	TR-3.5	19"	31.5#	15-3/4" to 19"	367-1895	30.0#	Plus 2-1/2 ft.
367-1880	TR-4.0	22"	41.7#	19-1/4" to 22"	367-1896	35.0#	Plus 3 ft.
367-1881	TR-4.5	26"	48.6#	22-1/2" to 26"	367-1896	35.0#	Plus 3-1/2 ft.
367-1882	TR-5.0	30"	61.0#	22-1/2" to 36"	367-1896	35.0#	Plus 4 ft.

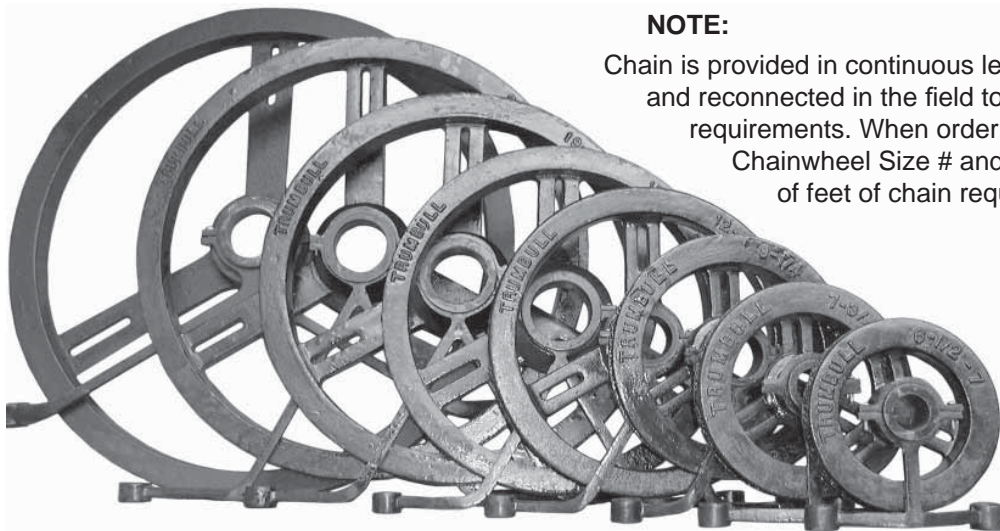

NOTE:

Chain is provided in continuous lengths. Easily cut and reconnected in the field to suit exact job requirements. When ordering, give the Chainwheel Size # and the number of feet of chain required.

NOTE: Also available in Type 316 Stainless Steel.

**Adjustable Chainwheel with Chain Guide
operates overhead valves from the floor.**



DIMENSIONS:

Chainwheel Size	TR-0.0	TR-1.0	TR-1.5	TR-2.0	TR-2.5	TR-3.0	TR-3.5	TR-4.0	TR-4.5	TR-5.0
Item#	367-1873	367-1874	367-1875	367-1876	367-1877	367-1878	367-1879	367-1880	367-1881	367-1882
Chainwheel Assembly Fits Handwheel O.D. Range	2" to 4"	4-1/4" to 5-3/4"	6" to 7-1/2"	7-3/4" to 9"	9-1/4" to 12-1/2"	12-3/4" to 15-1/2"	15-3/4" to 19"	19-1/4" to 22"	22-1/2" to 26"	22-1/2" to 36"
Chain Size	Size #2	Size 1/0			Size 4/0			Size 5/0		
Chain Item#	172-1650	367-1894			367-1895			367-1896		
Attachment Set Size	CD*	CD**	A		B	C				D
Boxed Weight	1.8 lbs.	4.2 lbs.	9.2 lbs.	12.9 lbs.	15.7 lbs.	22.0 lbs.	31.5 lbs.	41.7 lbs.	48.6 lbs.	61.0 lbs.
Bushing Size	none		Small		Medium		Large			
Bushing Bore, Min.	n.a.		5/8"		15/16"		15/16"			
Bushing Bore, Max.	n.a.		1-1/4"		1-7/8"		2-3/4"			
A - Overall Height w/Guide	5"	6-7/8"	8-3/4"	10-3/4"	12-5/8"	16"	19"	23"	27"	30"
B - Overall Width	4-1/4"	5-3/4"	8-9/32"	9-17/32"	11-5/16"	15-15/32"	18-7/16"	22-19/32"	26-1/2"	30"
C - Overall Depth	1-7/8"	2-3/8"	2-1/2"	2-1/2"	2-9/16"	2-9/16"	2-9/16"	2-5/8"	2-5/8"	3-5/16"
D - Slot Width in Arms	3/16"	3/8"	5/16"	5/16"	5/16"	7/16"	7/16"	7/16"	7/16"	9/16"
E - Inner Bolt Circle Diam.	1-1/2"	2-3/8"	3-1/8"	3-3/8"	3-3/4"	7-1/2"	9-13/16"	12-9/16"	16-7/8"	16-1/16"
F - Outer Bolt Circle Diam.	2"	3-7/16"	4-7/8"	5-15/16"	7-11/16"	11"	14-13/16"	17-9/16"	22-3/8"	25-11/16"
G - Hub Bore Diam.	7/16"	13/16"	1-1/2"	1-1/2"	2-1/8"	2-1/8"	3"	3"	3"	3"
H - Hub Recess Diam.	3/4"	1-7/16"	----	2-3/4"	3"	3-1/2"	5"	5"	5"	5"
I - Hub Recess Depth	3/4"	1-3/8"	----	3/8"	9/16"	9/16"	13/16"	7/8"	7/8"	1-1/2"

* Clamp Disk 0

** Clamp Disk 1

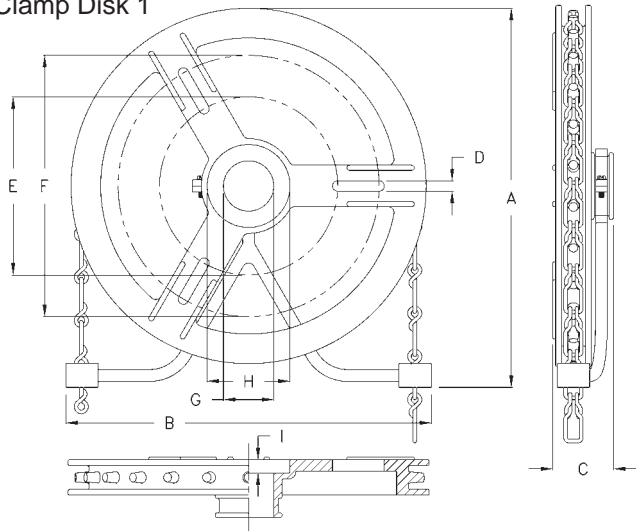

For Direct Mount Applications

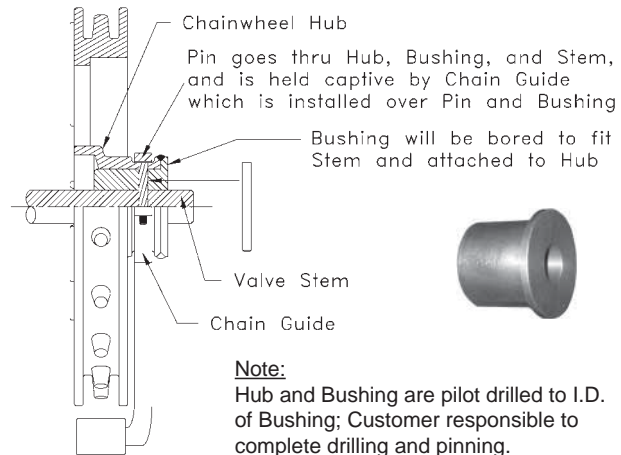

Machined Ductile Iron Bushing, shown with standard "min." round bore. Other bore sizes, shapes, tapers or keyways can be provided.

Attachment Sets

Chainwheel Sizes TR-1.5 thru TR-2.5 use two sets of Clamp Bases & Arms, plus one Band.

Chainwheel Sizes TR-3.0 thru TR-5.0 use three sets of Clamp Bases & Arms, and do not use a Band.

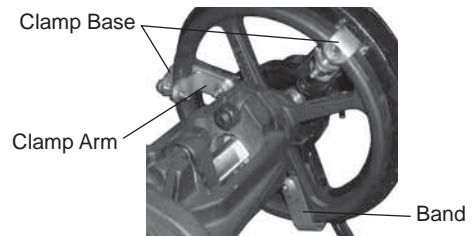
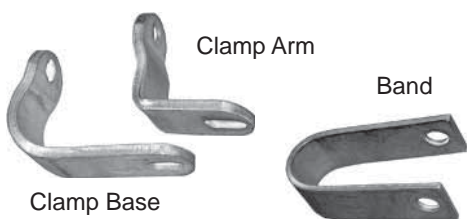



1040 N. Meridian Rd., P.O. Box 1556, Youngstown, Ohio 44501
 Phone: (330) 799-3333 Toll Free: 1-800-677-1799 FAX: (330) 797-3215

www.trumbull-mfg.com

UNIVERSAL CHAINWHEELS

Type 316 Stainless Steel

Pocket Type for TRUMBULL 316L welded machine chain

Trumbull Stainless Steel Chainwheels allow operation of overhead valves by means of a slight pull on the chain. Universal design allows Chainwheel to be clamped to handwheel, or pinned directly to valve stem.

Designed for corrosive environments, Trumbull Stainless Steel Chainwheels are Type 316 investment steel castings. Ideal in chemical processing, outdoor installations, or salt water environments.

All Chainwheels are furnished with attachment hardware for clamping to handwheel. See top of page G-22 for illustrations of clamping methods.

Pocket style chainwheels use smooth, welded link (proof coil) chain. See pages G-19 and G-20 for separate literature on Trumbull's ductile iron sprocket chainwheels using single loop chain, and bottom of page G-22 for comparison of both types.

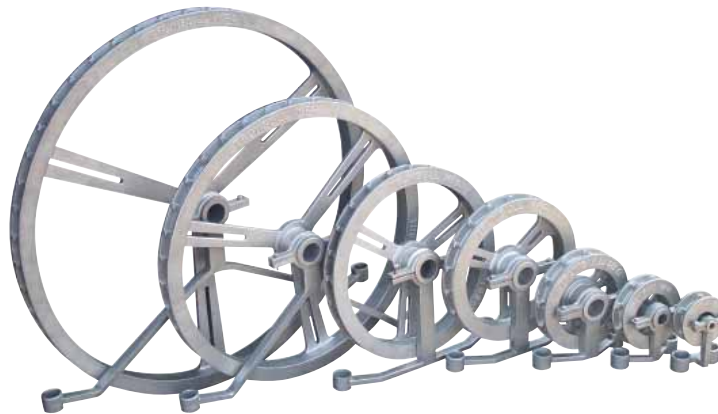

SPECIFICATIONS:

<u>Trumbull Item No.</u>	<u>Size No.</u>	<u>Diameter of Chainwheel</u>	<u>Range of Handwheels Chainwheel Will Fit**</u>	<u>Weight lbs.</u>	<u>Length of Chain Required (2x Drop)</u>
367-1825	TRS-4D*	4-1/8"	1-1/2" I.D. to 4-1/2" O.D.	4.6#	Plus 1 ft.
367-1830	TRS-6D*	5-7/8"	2-1/8" I.D. to 6-1/4" O.D.	8.4#	Plus 1 ft.
367-1833	TRS-8B	8"	7-1/2" O.D. to 10-1/2" O.D.	13.9#	Plus 1-1/2 ft.
367-1845	TRS-12B	11-5/8"	8-1/2" O.D. to 13-1/2" O.D.	19.1#	Plus 1-1/2 ft.
367-1850	TRS-15B	15-3/16"	9-1/2" O.D. to 17-1/2" O.D.	23.9#	Plus 2 ft.
367-1860	TRS-22B	22-1/4"	13" O.D. to 25" O.D.	32.6#	Plus 3 ft.
367-1870	TRS-29B	29-1/4"	17-3/4" O.D. to 32" O.D.	44.3#	Plus 4 ft.
367-1815	TRS Series 316L Stainless Steel Machine Chain, TRUMBULL Calibrated				
367-1816	TRS Series Connecting Link, Stainless Steel				

The ranges above are for Size "B" attachment stampings, furnished standard with TRS-8 thru TRS-29 chainwheels. Chainwheels can fit handwheel diameters outside these ranges by using optional hardware (see Table 1 on pg.G-22). Consult your sales rep for either shorter or longer attachment set stampings.

* D suffix denotes "Disc", used in lieu of standard clamping hardware; see top right of page G-22 for illustration.

**Optional hardware attachment sets are available to fit different ranges of handwheels (see Table 1 on page G-22).

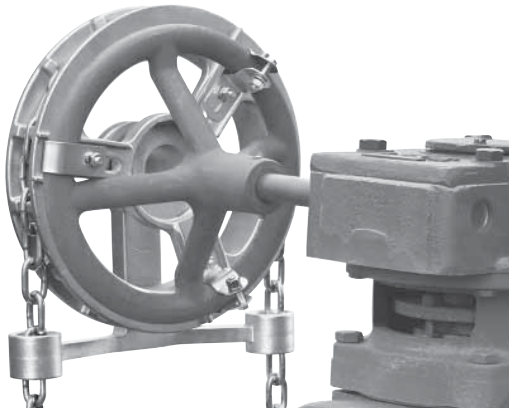

Attachment hardware for clamp-on installation. Furnished with TRS-8 thru TRS-29 chainwheels.

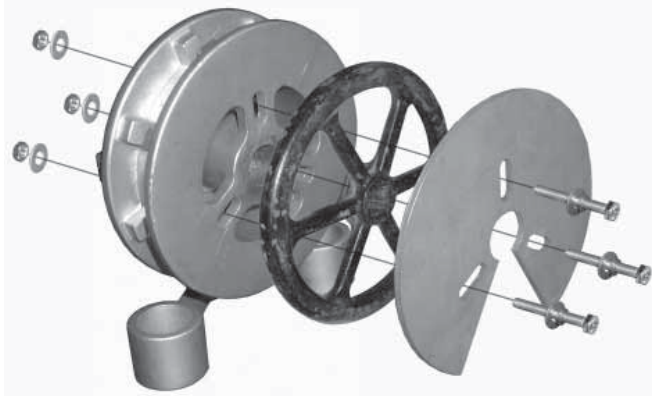

Clamping disc hardware for clamp-on installation. Furnished with TRS-4 and TRS-6 chainwheels. (Optional on the TRS-8.)

Optional bushing for direct mount installation is available. Consult Engineering for bushing and pin options.

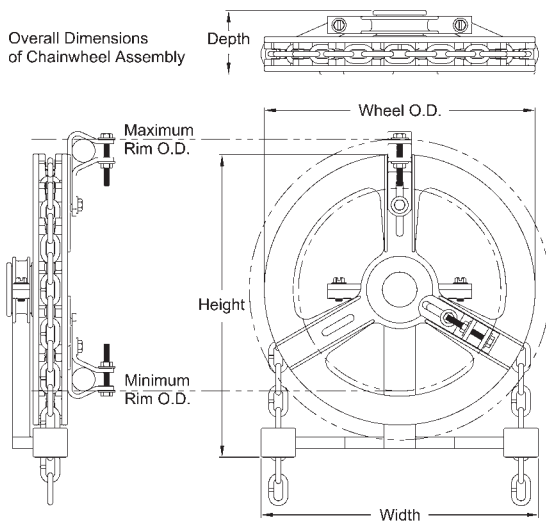

Overall Assembly Dimensions

Size	Wheel O.D.	Height	Width	Depth
TRS-4	4-1/8"	6-1/4"	4-5/8"	2-3/8"
TRS-6	5-7/8"	7-1/16"	6-3/16"	2-5/8"
TRS-8	8"	9"	8-7/16"	2-3/4"
TRS-12	11-5/8"	13-1/8"	12"	2-3/4"
TRS-15	15-3/16"	16-1/4"	15-5/8"	2-3/4"
TRS-22	22-1/4"	22-1/4"	22-5/8"	2-3/4"
TRS-29	29-1/4"	29-1/4"	29-1/2"	2-3/4"

TABLE 1:

Handwheel O.D. ranges with optional attachment sets.

Size	"A" Attachment Set		"C" Attachment Set	
	Min. O.D.	Max.O.D.	Min O.D.	Max O.D.
TRS-4	n.a.	n.a.	n.a.	n.a.
TRS-6	n.a.	n.a.	n.a.	n.a.
TRS-8	6"	8"	12-1/4"	15-1/2"
TRS-12	7"	11"	13-1/4"	18-1/2"
TRS-15	8"	15"	14-1/8"	23"
TRS-22	11"	22-1/2"	17-1/2"	30"
TRS-29	16"	29"	22-1/2"	37"

Note: Chainwheels furnished standard with "B" Attachment Sets; see page G-21 for range of fit.

For optional ranges, using "A" or "C" sets, see chart on right...

Handwheels with hubs projecting above the handwheel rim may cause interference with the attachment set stampings in some instances. Please consult Trumbull or send us a drawing of your handwheel to avoid attachment problems.

Illustration shows the difference between sprocket and pocket type wheels.

Pocket Type Wheel:

Straight link machine chain fits in pockets in the wheel.



Smooth chain links provide more comfortable operation.

Sprocket Type Wheel:

Single loop chain engages teeth in the wheel.

