

Snap Acting Relays

YT-500, YT-505, YT-510, YT-515

# USER'S MANUAL

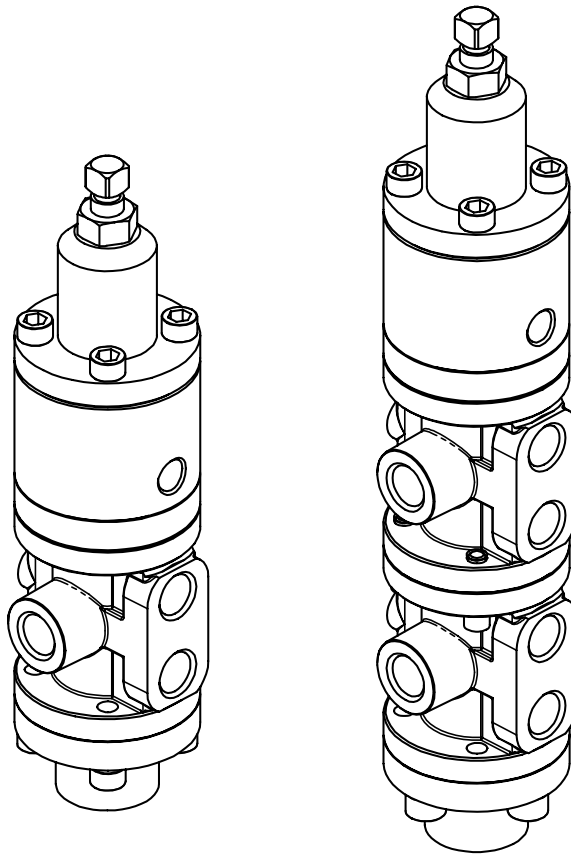

## Product Description

Snap Acting Relay, YT-500 (YT-505) and YT-510 (YT-515), senses supply pressure and changes the direction of the air flow when supply pressure is lower than setting pressure. It also provides "Fail-Position" function when the supply pressure gets lower especially when there is damages on pipelines.

## Product Characteristic

- It responses to very small changes and has high accuracy.
- Versatility can be enhanced by having different material and capacity.
- 100 mesh screen filters small dust entering.

## Label

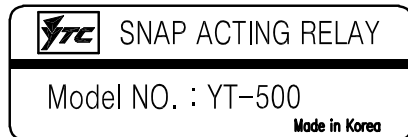

**Model NO.:** Indicates product's model, suffix, and options. (if any).

## Suffix Symbol

YT-500 (YT-505) and YT-510 (YT-515) follow suffix symbols as below.

YT-500 / YT-505 / YT-510 / YT-515 [1] [2]

[1] Acting Type	S : Single Acting D : Double Acting
[2] Connection Type	2 : NPT

## Specification

### ● YT-500 & YT-505

Category	YT-500		YT-505	
	Single	Double	Single	Double
Max Supply Pressure	Max. 10kgf/cm <sup>2</sup> (142psi)			
Signal	1.4~7kgf/cm <sup>2</sup> (100psi)			
Flow Capacity (Cv)	0.7			
In/Output Connection	NPT 1/4			
Signal Connection	NPT 1/8			
Linearity	±1% (F.S.)			
Hysteresis	1%			
Ambient Temperature	-20℃~70℃			
Material	Brass		Stainless Steel 316	
Weight	0.8kg	1.2kg	1.1kg	1.7kg

### ● YT-510 & YT-515

Category	YT-510		YT-515	
	Single	Double	Single	Double
Max Supply Pressure	Max. 10kgf/cm <sup>2</sup> (142psi)			
Signal	1.4~7kgf/cm <sup>2</sup> (100psi)			
Flow Capacity (Cv)	0.9			
In/Output Connection	NPT 3/8			
Signal Connection	NPT 1/4			
Linearity	±1% (F.S.)			
Hysteresis	1%			
Ambient Temperature	-20℃~70℃			
Material	Brass		Stainless Steel 316	
Weight	2.1kg	3.3kg	2.6kg	3.4kg

1. NPT size is only available due to YT-505 and YT-515's material.
2. Above specification is retrieved from YTC standard test. Actual specification can be different than mentioned above depends on the field's environment.
3. Please contact YTC or appropriate agent for replacement or for more detailed inquiry.

### Parts and Assembly

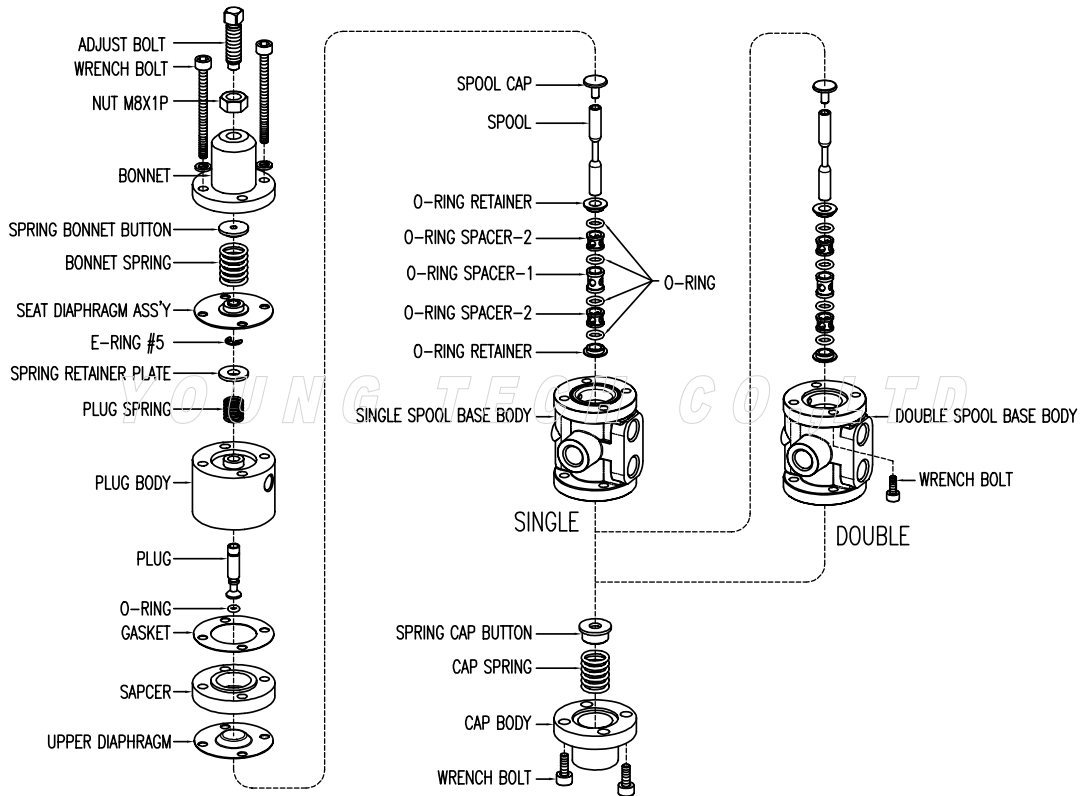

Please be knowledgeable of product's major parts and assembly steps for future maintenance.

### Operation Logic

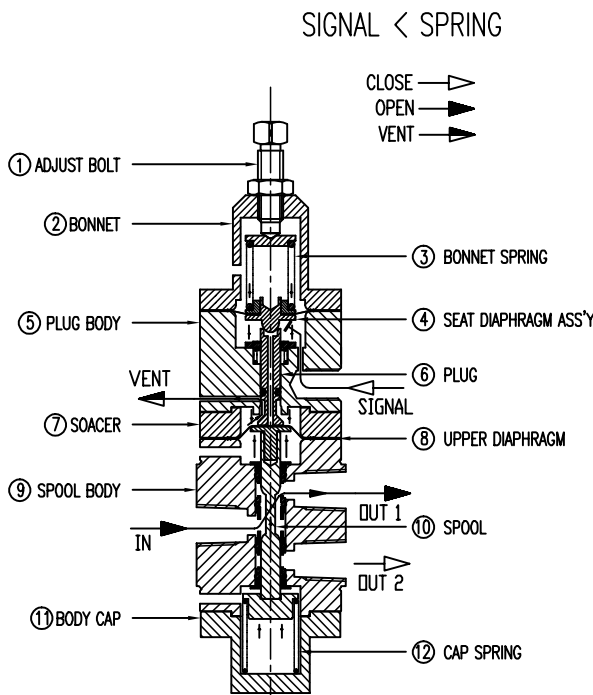

When signal (main) pressure is higher than setting pressure level, signal pressure pushes seat diaphragm(4) and is separated from the plug(6). Supply pressure is then exhausted through "OUT2" port by pushing spool(10). Opposingly, when signal (main) pressure is lower than setting pressure level, seat diaphragm(4) is being pushed downward and will attach to the plug(6). Then upper diaphragm(8) and spool(10) will rise, which will result supply pressure to exhaust through "OUT1" port.

Dimension (outer)

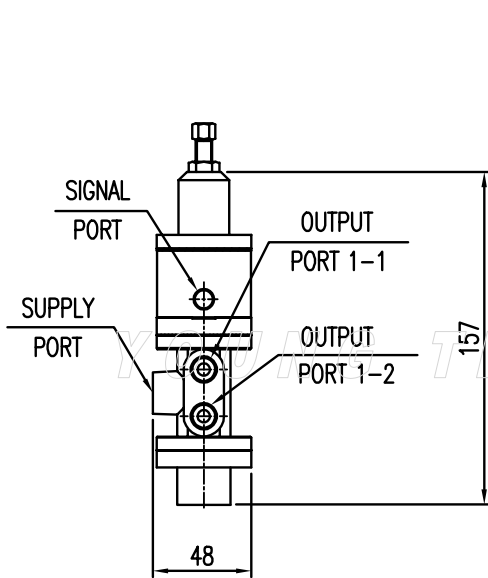

<YT-500S & YT-505S>

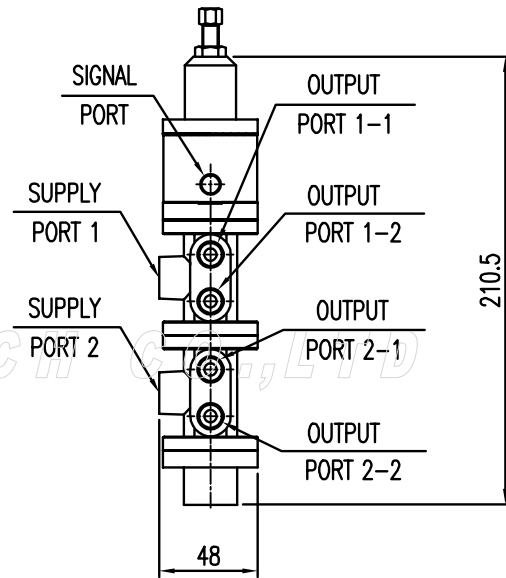

<YT-500D & YT-505D>

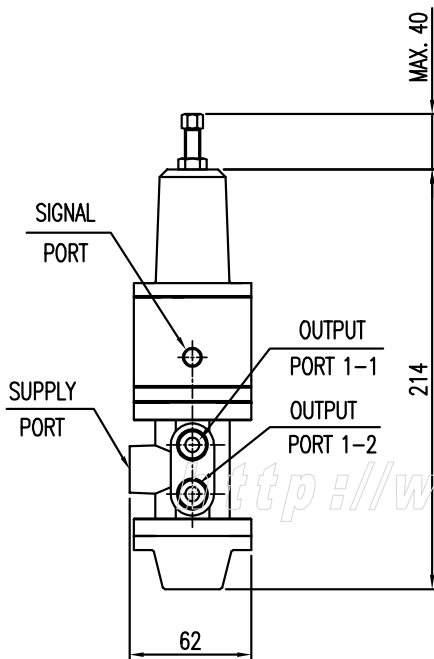

<YT-510S & YT-515S>

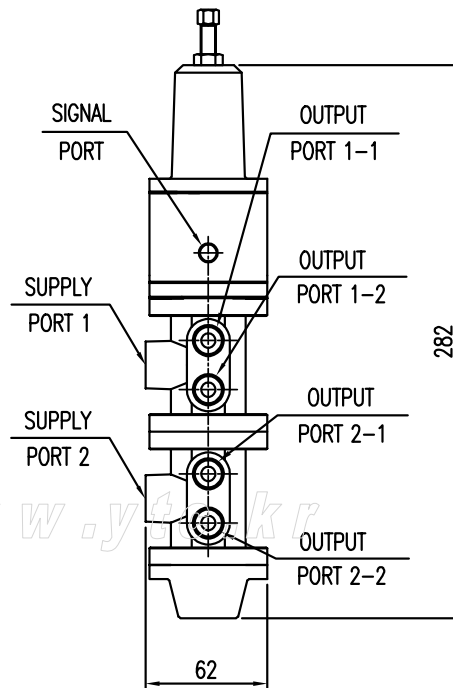

<YT-510D & YT-515D>

## Installing

### ⚠ Caution

When installing the product, please follow below procedures.

- Always wear safety equipments and follow safety procedures.
- Please operate within the range of specified capacity in the manual. If exceeded, the product can be damaged and may result serious damages and accident.
- Air must be clean, dry, and non-corrosive, which must pass filter.
- Please use pressure measurement device when setting pressure level.

## Pipe Connection

YT-500 (YT-505) and YT-510 (YT-515) can be installed without a bracket <Figure1>, which can be installed on through the pipeline. Before connecting with pipeline, please make sure pipeline is emptied, and the size of the pipeline is appropriate for required capacity. If YT-200 must be installed on the bracket, please make a bracket according to the product's dimension. <Figure 2>

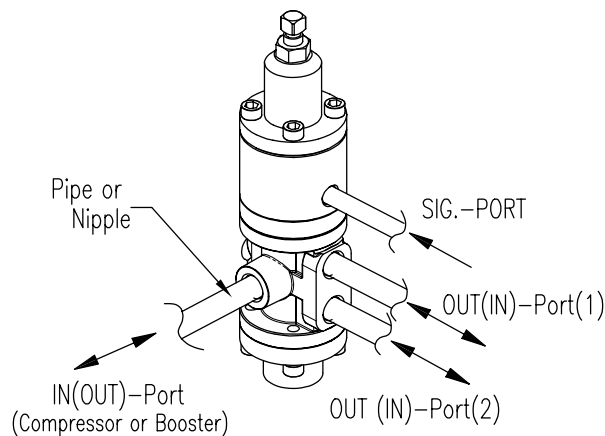

<Figure 1>

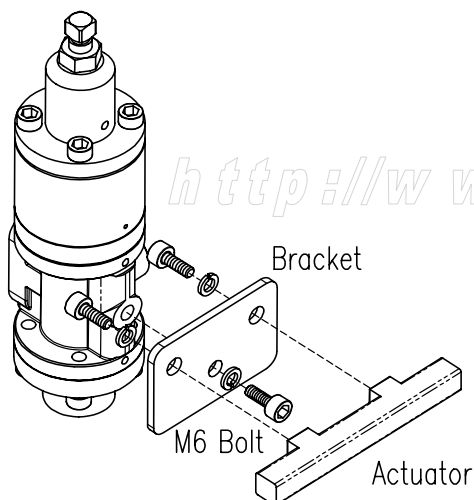

<Figure 2>

Install Example

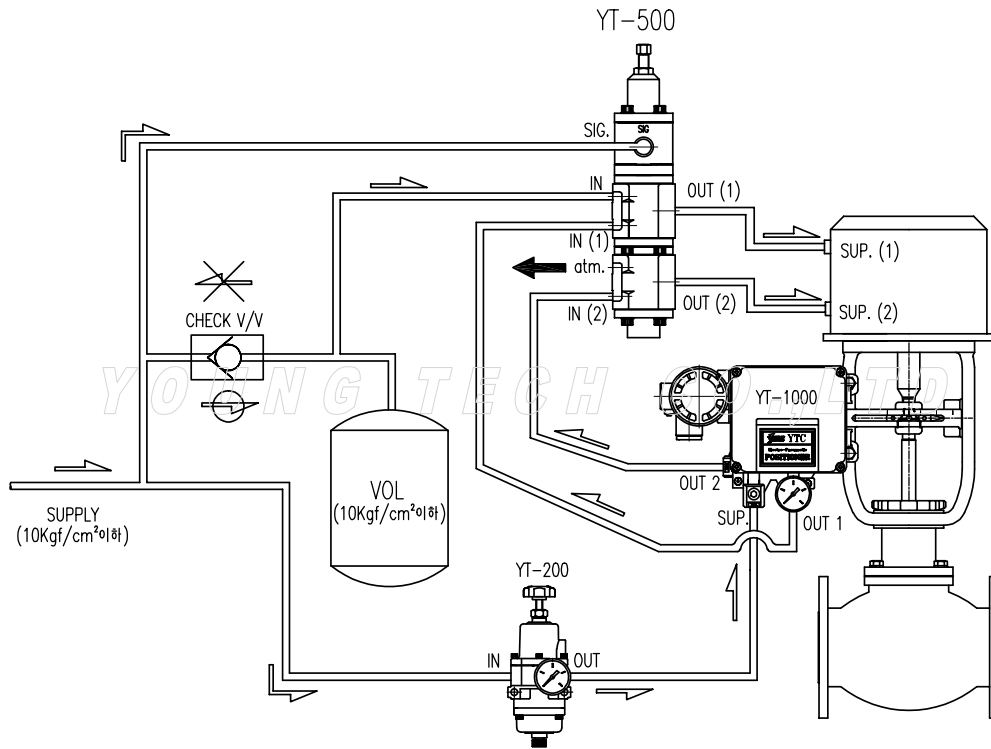

<Linear Actuator Type>

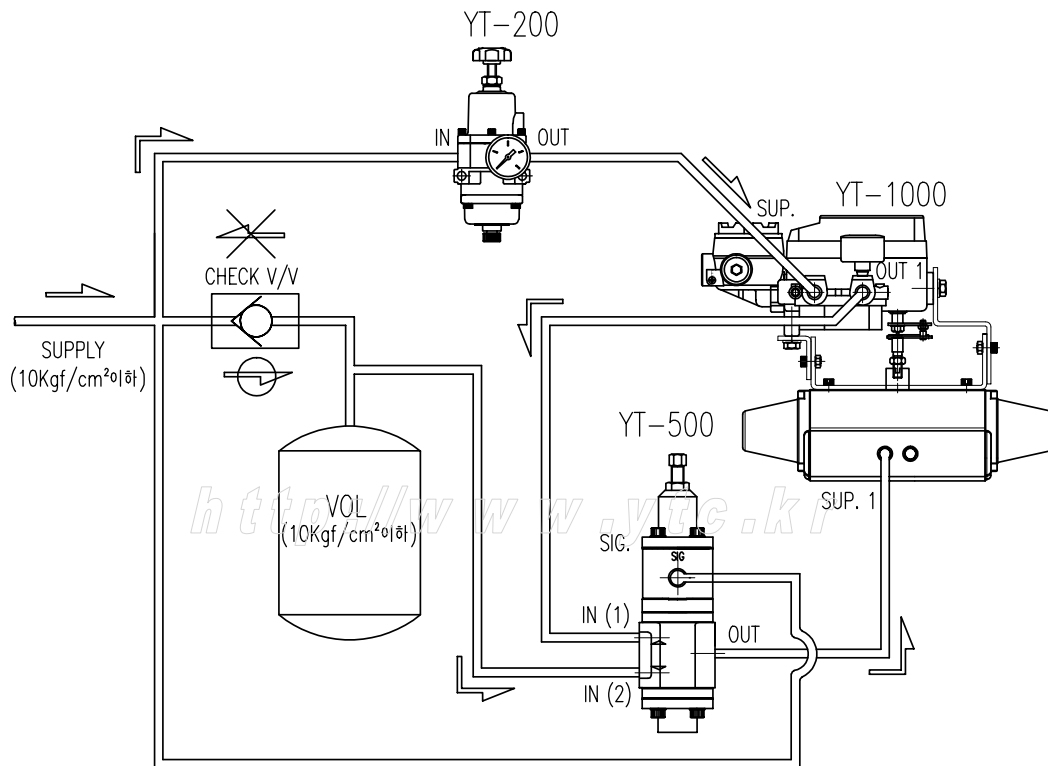

<Rotary Actuator Type>

## Maintenance

Please refer to below table (repair kit) and parts' name (pg 3). Before replacing any parts, please make sure to follow field's safety instruction and manual to avoid any accidents and damages to the product.

### Repair kit

Part Name	Qty
Seat Diaphragm Assembly	1 (ea)
Gasket	1 (ea)
Upper Diaphragm	1 (ea)
O-rings	10 (ea)

When using Repair Kit, all of the parts must be replaced at the same time. Partial replacing part may result shortening product's life cycle.

## Troubleshooting

▶ **No exhaustion to OUT1 port when signal pressure is lower than setting pressure level**

Please check if setting pressure is correctly set. If setting pressure is extremely high, please lower the setting pressure level. Default setting pressure level is 3 kgf/cm<sup>2</sup> when manufactured.

▶ **No exhaustion to OUT2 port when signal pressure is higher than setting pressure level**

Please check if setting pressure is correctly set. If setting pressure is too low, please increase the setting pressure level. Default setting pressure level is 3 kgf/cm<sup>2</sup> when manufactured.

▶ **Air pressure is exhausted through Bonnet holes**

Seat diaphragm assembly may be damaged. If it is damaged, please replace the seat diaphragm assembly.

▶ **Air pressure is exhausted through Body Plug**

Please check there is no substances between Seat Diaphragm Assembly and Plug or may be damaged. If damaged, please replace Seat Diaphragm or clean the area.



## Manufacturer Warranty

- For the safety, it is imperative to follow install instruction in the manual. It is not manufacturer's responsibility for any damages due to the user's negligence.
- It is not manufacturer's responsibility for any damages or accident due to user's alteration of the product and parts. If alteration or modification is necessary, please contact the manufacturer directly.
- Manufacturer warrants the product from the date of original retail purchase of the product for one (1) year, except as otherwise stated.
- Manufacturer warranty will not cover the products that the product have been subjected to abuse, accident, alteration, modification, tampering, negligence, misuse, faulty installation, lack of reasonable care, repair or service in any way that is not contemplated in the documentation for the product, or if the model or serial number has been altered, tampered with, defaced or removed; damages that occurs in shipment, due to act of God, failure due to power surge, and cosmetic damage. Improper or incorrectly performed maintenance or report voids this Limited Warranty.
- For detailed warranty information, please contact the corresponding local Young Tech Co., Ltd office or headquarter office in South Korea.

## Young Tech Co., Ltd

---

Address : #662-8 Pungmu-Dong, Gimpo-City, Kyunggi-Do, South Korea  
Telephone: +82-31-986-8545  
Fax: +82-31-986-2683  
Website: <http://www.ytc.kr>

---

User Manual and other information on the documents are subjected to change without any notice.  
Please visit website for most updated information. Printed Date: June, 2007