

L120 Series

Multi-turn electric  
valve actuators for  
a wide range of  
process applications



**Limitorque**

**Limitorque's L120 Series  
multi-turn actuators have  
a solid record of making  
valve control easier  
in a wide variety of  
demanding applications.**

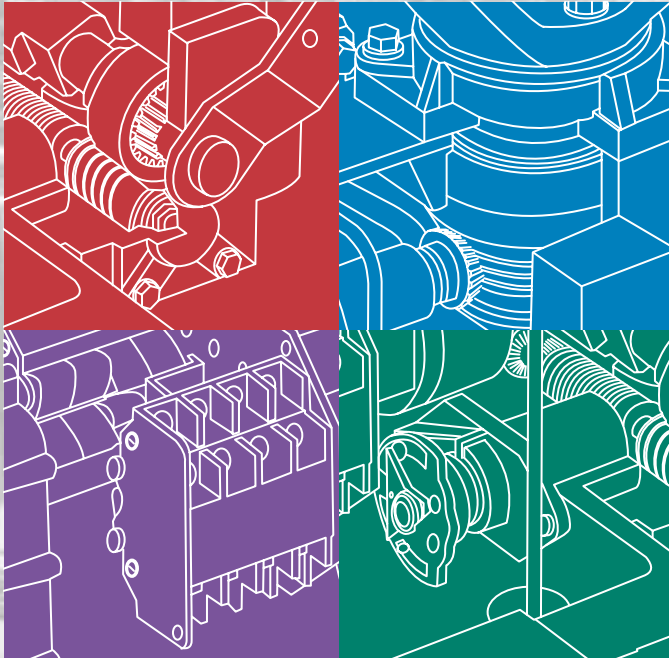

Proven performers under the most challenging circumstances, Limitorque's L120 actuators are ideal for valves requiring rotary or linear movement. With nine unit sizes, **L120 electric**

**actuators make**

**it easy** to meet or exceed your requirements for positive,

dependable valve

actuation.

Whether used with gate and globe valves, penstocks, or sluice gates, versatile L120 Series actuators operate without modification in any rising or non-rising stem application for

linear-action valves. When combined with a Limitorque WTR Series quarter-turn gear operator, L120 actuators can also be used to control butterfly, ball, and plug valves, as well as damper drives, flop gates, or any other device which requires rotary movement.

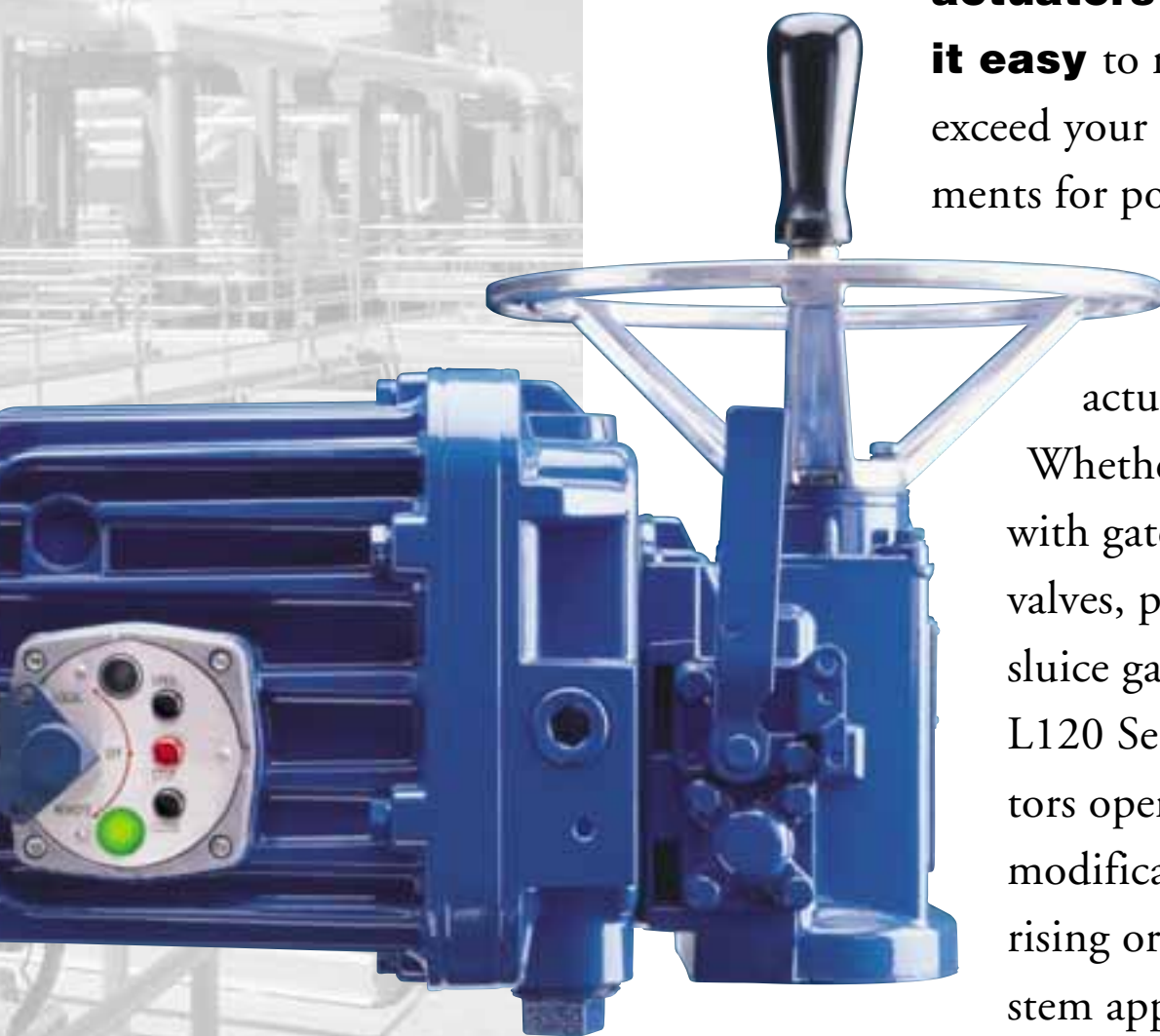



**Rugged, reliable, and versatile, L120 units are proven performers in the most challenging applications.**

Right now thousands of L120 actuators are operating in some of the world's most demanding conditions. In places where nothing less than day-after-day dependable operation is acceptable, L120 is the actuator of choice due to its years of demonstrated reliability—a record matched by no other actuator.

L120 units are specified for use in petrochemical, power generation, and water and waste treatment applications where failure of a single actuator can be extremely costly...even catastrophic.



**Low-maintenance requirements make the L120 Series ideally suited for water and waste treatment applications.**

**L120 units meet rigid safety requirements and are available in weatherproof, explosionproof, and submersible configurations.**



Solid design and durable construction qualify the L120 as an actuator without equal for applications involving harsh environmental conditions. Its successful record with challenging requirements and its compatibility with advanced process control systems make L120 actuators the best combination of proven and leading-edge technologies. Backed by comprehensive technical support services, product documentation, and spare parts availability, the L120 Series is an easy choice for flexible, dependable valve control.

**L120 makes valve control easier for some of the world's most demanding customers.**

**Petrochemical installations** such as refineries, pipelines, terminals, tank farms, cokers, and off-shore platforms rely on the L120's safety, endurance, and operational efficiencies. The L120 has network compatibility, explosionproof certification, and resistance to lightning, EMI, and fire.

**Power generation plants** value the L120's availability, controls versatility, and reliable performance. The L120's rugged design and construction quality stands up to vibration, high-pressure steam, and extreme temperatures.



**Integral control packages include plug-in interconnect boards that increase control functionality for stand-alone or networked units.**

**L120 actuators are automated in a DDC-100 digital control network at a petrochemical storage facility in Southeast Asia.**



**Water and waste treatment facilities**

benefit from L120's low-maintenance requirements and modulating control capabilities. Units meet AWWA standards and easily fit the industry trend toward modern controls networks. The wide range of options in the L120 Series allows specification needs to be met cost-effectively.





**Designed to provide positive, dependable actuation.**

The time-tested design and solid construction of the L120 Series allow these actuators to handle up to 60,000 foot-pounds (81,600 Nm) of torque, and up to 500,000 pounds (225,000 Kg) of thrust. Durable torque overload protection is provided in both directions of valve travel. Rugged enclosures are available in weatherproof, submersible, and explosionproof configurations.

L120 units can also be coupled to gearboxes such as Limitorque's B320, WTR, or HBC units for motorized operation of valves requiring quarter-turn or increased torque and/or thrust.

All L120 units are factory-lubricated and weatherproofed for service in temperatures ranging from -20°F to 150°F (-29°C to 65°C). Submersible and explosionproof versions of all L120 models are available for appropriate applications. Refer to pages 8 and 9 for L120 specifications.

## L120-190 Series

**The versatile midrange member of the L120 family delivers more than seven times the thrust of the smallest units in the line.**



## L120-85 Series

**This model and larger units are made of cast iron. Optional ductile iron construction is also available.**

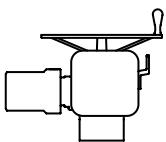

**L120-10 through 40 Series**

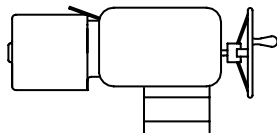

**L120-85 Series**

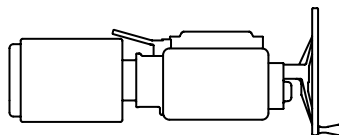

**L120-190 Series**

## L120-10 through 40 Series

These models utilize die-cast aluminum with an option for ductile iron construction to withstand the most rigorous applications.

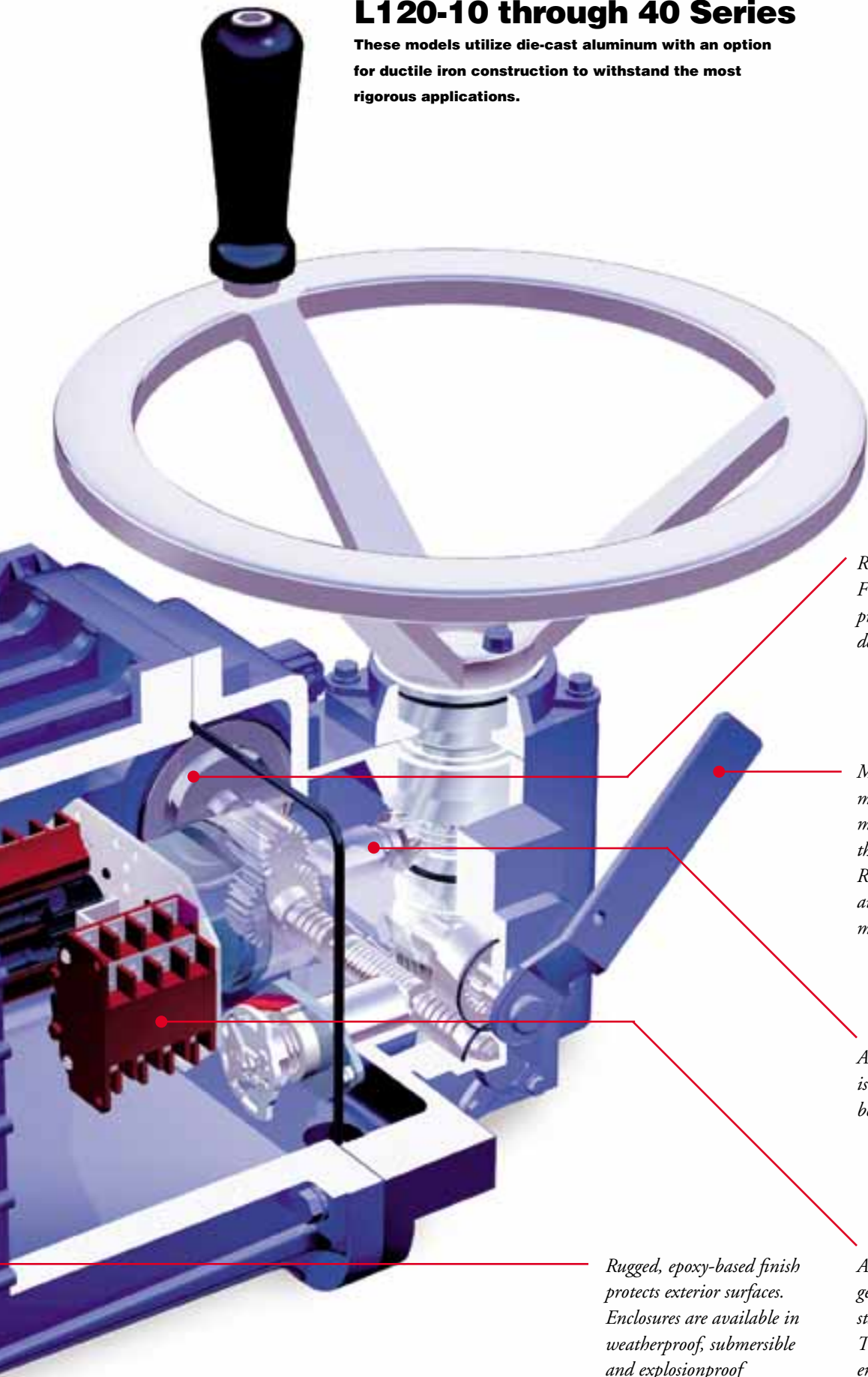

*Reliable motor includes class F insulation and thermal protection; it is specially designed for valve actuation.*

*Manual declutch lever mechanically disconnects the motor from the handwheel through the clutch assembly. Return to motor operation is automatic in all units when motor is energized.*

*All metallic gearing is lubricated. Anti-friction bearings are used throughout.*

*Rugged, epoxy-based finish protects exterior surfaces. Enclosures are available in weatherproof, submersible and explosionproof construction. Gaskets and seals throughout prevent exposure to the elements.*

*A four-position, 16-contact geared limit switch is standard on all models. The gear train is fully enclosed.*

**Compatible control options include pushbuttons, integral packages, and digital networks linked direct-to-host.**

Even though it has been at work for years, the L120 is at home in the most modern process control environments. It is compatible with a wide range of control options—from stand-alone units with local pushbuttons to open standards-based direct-to-host DDC-100 networks with up to 250 actuators.

**Human interfaces**

Control stations are available with a variety of buttons, indicating lights and selector switch options. Padlock capability and breakglass covers are available. The SW93 series control stations offer three buttons, two lights, and a padlockable three-position selector switch as standard for use with UEC controllers. Switch stations can be supplied in the compartment cover (standard) or for remote mounting.

**Control compartments**

Options for compartment sizes fit different control requirements. The smallest size is supplied to suit any application, unless another size is specified.

- **L120-10 through 190** Three sizes are available: standard size for NCU and BIC, plus some BIC configurations; minimum integral compartment size for clamshell, UEC integral controls, and L120-10 through 40 single-phase BIC; and maximum compartment size for some modutronic controllers and customized options which do not fit minimum compartment size.

- **L120-420 and larger** Two sizes apply: a standard compartment size for non-integral controls and an integral compartment size for integral controls.

**Control switches**

Typical SW stations offer basic control functions

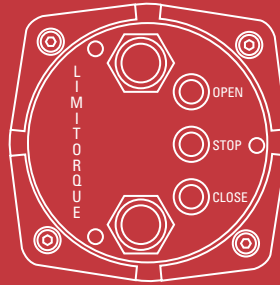

SW320

Advanced SW stations support UEC control functions

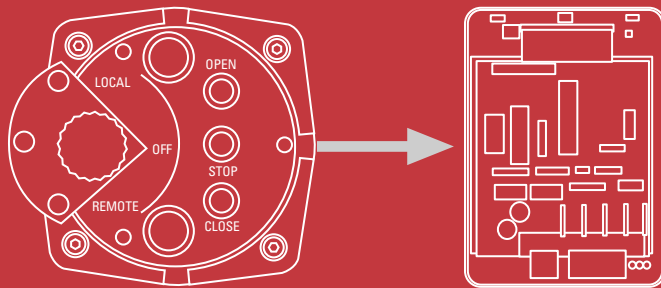

SW93

UEC

**L120 control compartments**

**Standard compartment**

- L120-10 through 190 for NCU and BIC controls
- L120-420 and larger for non-integral controls

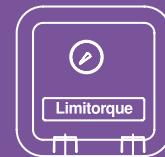

**Minimum integral compartment**

- L120-10 through 40 for single-phase BIC, clamshell and UEC controls
- L120-85 through 190 for clamshell and UEC controls

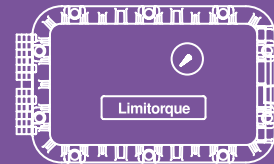

**Maximum integral compartment**

- L120-10 through 190 for some modutronic packages and other customized options
- L120-420 and larger for integral controls

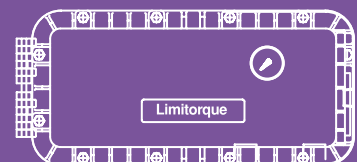



### Integral control packages expand L120 functionality.

Standard packages are provided on printed circuit boards to reduce the need for hard wiring. Local control stations offer a choice of pushbutton, light, and selector switch options. Control functions vary according to application requirements.

#### Integral package options:

- **No Controls Unit (NCU)** Control of open/close applications can be linked to a motor control center or PLC to keep equipment costs to a minimum.
- **Basic Integral Controls (BIC)** include integrated reversing contactor, transformer, fuses, and interlocks.
- **Integral Reversing Controls (IRC)** include BIC functionality plus plug-in interconnect board and increased options. IRC packages are mounted on hinged clamshell bracket for easy accessibility.
- **Modutronic Controls (BIC/MOD 20)** offer a choice of integral packages for positioning or process control functions in response to analog signals. Use with BIC and IRC packages.
- **The Universal Electronic Controller (UEC-3, UEC-3-MPC, UEC-3-DDC)** is supplied in high density polymer enclosure for increased isolation of electronic components. The UEC includes BIC functionality, plus advanced diagnostics and function configurability. Options include:
  - Modulating Position Control (MPC) and
  - Distributed Digital Control (DDC).

### Advanced features simplify control characteristics

#### No-controls unit (NCU)

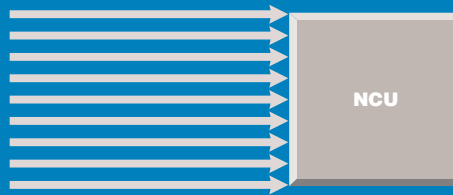

#### Basic integral control (BIC)

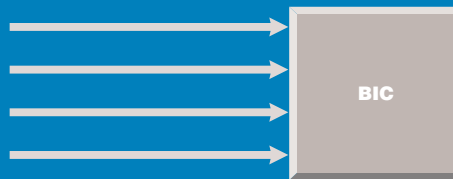

#### Universal Electronic Controller with Distributed Digital Control (UEC-3-DDC)

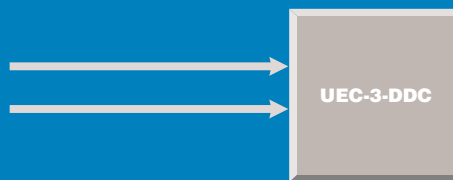

### L120/DDC-100 direct-to-host networks support up to 250 field units

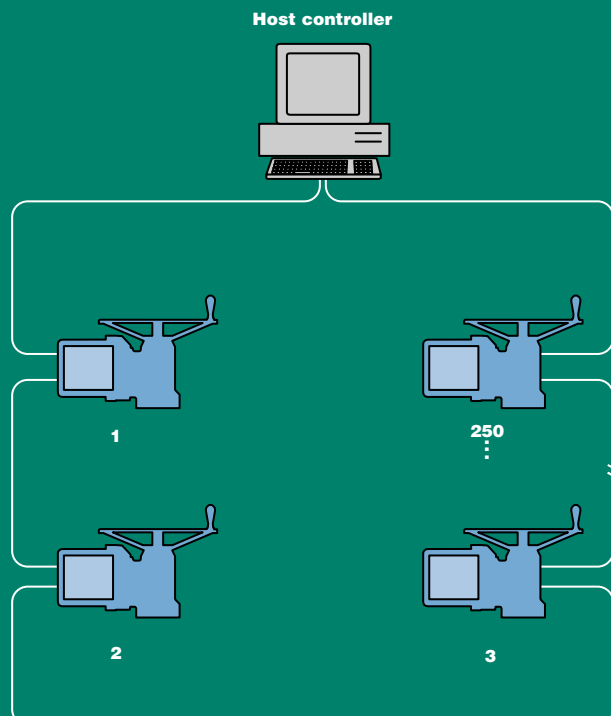

## L120 Specification

### Gear Housing

- Cast aluminum, L120-10 through 40; cast iron, L120-85 through 2000.
- Lubrication—Exxon EP-0 grease. L120-85 uses EP-00.
- Gear reduction—Double reduction type.
  - Worm gear (alloy bronze) and spur gear (heat-treated steel), L120-10 through 85.
  - Worm gear (alloy bronze) and spur gear (heat-treated steel), and worm (alloy steel) and helical gearing (heat-treated steel), L120-190 through 2000.

### Electrical compartment covers

- Cast aluminum, O-ring sealed.
- Hardware is nickel-plated carbon steel, L120-10 through 85, and L120-190 through 2000. Stainless steel optional for non-XP.

### Motor

- Available as 4 pole, 1800 RPM (60hz) or 1500 RPM (50hz); 2 pole, 3600 RPM (60hz) or 3000 RPM (50hz); 8 pole, 900 RPM (60hz) or 750 RPM (50hz).
- Squirrel cage induction for 3-phase and capacitor start-induction run for single-phase.
- Power supply—3-phase motors, suitable for 3/60/230, 3/60/460, 3/60/575, 3/50/380, or 3/50/415.
- Nominal duty is 15 minutes.
- Dynamic torque is nominal 20% of start torque.
- Class F insulation.
- Two Class B thermal contacts embedded within motor windings provide thermal protection.

### Limit switch

- Gear driven, cam operated, snap acting.
- 4 rotor/16 SPST contact switches (4 contacts per rotor—2 n/o and 2 n/c). Rotors may be set to open or close at any valve position.
- Contact rating is 600 volts per ICS-125.6. Current rated 6 amps resistive and 60 amps inrush at 120 VAC.
- Max drive sleeve turns (4-gear) rated 630 for L120-10; 740 for L120-20; 640 for L120-40; 900 for L120-85; 3110 for L120-190; 3300 for L120-420; 2850 for L120-800; 1210 for L120-2000.

### Torque switch

- L120-10 through 85: Heavy-duty inlaid silver contacts, 600 volts, and one SPST contact each for open/closed direction dedicated to actuator torque protection.
- L120-190 through 2000: 600 volts per ICS-125.6, 6 amps resistive and 60 amps inrush at 120 VAC. One SPST contact each for open/closed direction dedicated to actuator torque protection.

### Reversing contactor

- Available at 12-, 25- or 50-amp ratings, selected according to motor size.

### Enclosure

- WP units suitable for NEMA 4.
- XP units (L120-10 through 85).
  - (NCU and BIC 3-Phase) suitable for Class I, Groups B, C and D, Division 1 and 2 service and Class II, Groups E, F and G.
  - (Clamshell, UEC, MPC, DDC, BIC 1-Phase) suitable for Class I, Group D, Division 1 and 2 service and Class II, Groups E, F and G.
  - L120-190 through 2000, suitable for Class I, Groups C and D, Division 1 service and Class II, Groups E, F and G.

### Output drive B4

- Steel torque bushing, no internal machining. Torque bushing is flush with mounting base, not extended.

### Handwheel/declutch

- Fabricated steel, or ductile iron for side-mounted; cast aluminum for L120-10 top-mounted only. Handwheels are connected directly to drive sleeve (L120-10, 20 and 40). L120-85 operates through the worm set. Declutch lever is padlockable in motor position.

### Mounting base

- Supplied to MSS (English taps) standard. Optional ISO bases available.

### Paint

- TNEMEC 69/E-coating (electro-deposition) for L120-10 through 40; TNEMEC 69 high-build epoxoline II for L120-85 through 2000. Both coatings are suitable for 500-hour salt spray.

### Temperature rating

- Standard operating temperature range is from -20°F to 150°F. Optional extended range available.
- FM explosionproof rating -20°F to 140°F (-20°C to 60°C)

### Unit nameplate

- Limitorque name, point of manufacture, unit size, order number, serial number, space for customer tag information, CE 95 stamp. Nameplate located on back of unit opposite limit switch compartment.

### Motor nameplate

- ID number, start torque, run torque, enclosure type, RPM, volts, full load amps, locked rotor amps, insulation class, duty, space heater size, horsepower, service factor, phase, cycles, motor code, ambient temperature, connection diagram.

### XP nameplate

- L120-10 through 85:
  - NCU and BIC 3-Phase—Unit can be nameplated as Class I, Groups B, C and D, Divisions 1 and 2 and Class II, Groups E, F and G with Limitorque or FM. CSA label used for Group C only.
  - Clamshell, UEC, MPC, DDC, BIC (single-phase)—Nameplated as Class I, Group D, Division 1 and 2 and Class II, Groups E, F and G with Limitorque or FM.
  - Clamshell, UEC, MPC, DDC, BIC (3-phase)—Nameplated as Class I, Group C and D, Division 1 and 2 and Class II, Groups E, F and G with Limitorque or FM.
  - Cenelec IIB nameplate for L120-10 through 85 with standard and minimum integral compartment.
- L120-190 through 2000:
  - Nameplated as Class 1, Groups C and D, Division 1 and Class II, Groups E, F and G with Limitorque, FM or CSA label. If not specified, the Limitorque label will be used.
  - Cenelec IIB nameplate for L120-190 with standard and minimum integral compartment.

### Options

- **Flip-flop indication** Local position indicator shows open-intermediate-closed positions and is driven by gear limit switch rotors. Window in compartment cover shows indicator.
- **Local continuous position indication** Local position indicator shows continuous valve position in percentage open via dial, and is driven by dedicated gear set selected per application. Window in compartment cover shows indicator.
- **Local/remote indication** Includes local continuous position indicator with a 1000-ohm potentiometer. Potentiometers transmit valve position to remote location.
- **R/I converter** Sends remote valve position indication signal via 4-20mA signal. Internally-powered.
- **Side-mounted handwheel (L120-10 through 40)** Bevel gear attachment may be added to reduce effort required to operate handwheel, requiring more turns.
- **Handwheel spur (L120-190 through 2000)** May be added to reduce effort required to operate handwheel, requiring more turns.
- **5-gear limit switch** Used when the number of drive sleeve turns exceeds capacity of 4-gear limit switch. Provides 10 times the number of turns as 4-gear switch.
- **Double-pole torque switch** Provides an additional SPDT contact in each direction that actuates when set torque is exceeded. Used as indication of over-torque condition.
- **Ductile iron housing (L120-10 through 40)** Ductile iron for load-carrying components.
- **Spring compensation (L120S) (L120-190 through 2000)** SB-type spring-compensated stem nut used on high-speed, or high-temperature, torque-seated applications.

- **Position feedback for DDC** Communicates valve position to remote location via DDC-100 network. Includes local position indication, 1000 ohm potentiometer, and DDC analog channel. Used with DDC base unit.
- **External analog feedback for DDC** Allows external analog signals to be connected to DDC-100 field unit, converted to digital signals, and transmitted over DDC-100 network. Four signals may be accommodated. Includes DDC analog channel. Used with DDC base unit.
- **Positioning control for DDC** Permits positioning of valves over DDC-100 network. Positioning commands valve to any point of travel, in 1% increments. Includes local position indication, 1000 ohm potentiometer, and DDC-100 analog channel. Used with DDC base unit.
- **2-speed operation for UEC and DDC** Allows unit to be pulsed on and off, achieving slower operating speed for all or part of valve stroke. Default pulse rate is 2 seconds on, 10 seconds off, adjustable from 50ms to 12.75 seconds in 50ms increments. Configured via RS-232 link and dedicated software.

### Testing summary

Weatherproof enclosures meet NEMA 4, NEMA 4X, and IP67. Submersible actuators are suitable for NEMA 6 and IP68. Explosionproof enclosures fully conform to and are certified to be compliant to the following:

- Factory Mutual (FM)—Class I, Division 1 and 2, Groups B, C and D and Class II, Division 1 and 2, Group G.
- Canadian Standards Association (CSA)—Class I, Division 1, Groups C and D and Class II, Division 1, Groups E, F and G.
- CENELEC—EExd IIB.
- Japanese Industry Standards (J.I.S.)—JISd2G4.
- Australian (SAA)—EExd IIB.

Limitorque's factories are certified to ISO 9001 standards and maintain the highest quality of performance throughout the manufacturing processes.

L120 actuators meet the following seismic and vibration criteria: NTS Labs, Acton, MA, Test Report #31437-94M dated 3/28/94 to the following:

- Sine survey; 5 to 200 Hz @ 0.75 g.
- Sine cycling; 5 to 200 Hz to 5 Hz @ 0.75 g.
- Sine cycling; 2 to 35 to 2 Hz @ 1.0 g; 10 cycles.
- Sine dwells; 2 to 35 to 2 Hz @ 1/3 octave intervals, 5.0 g's @ 15 sec. dwells each frequency.

Note: Standards are applicable to most units.



## L120 series performance

(3-phase-50Hz/380, 400, and 415 Volt — 60Hz/230, 460, and 575 Volt)

Unit	Maximum Torque Capacity		Maximum Thrust Capacity		Output Speed Range (RPM)	
	Ft.-Lbs.	NM	Lbs.	Kg	60Hz	50Hz
L120-10	100	136	10000	4500	12-250	10-210
L120-20	200	272	20000	9000	12-250	10-210
L120-40	400	544	30000	13500	24-250	20-210
L120-85	850	1156	45000	20250	24-192	20-160
L120-190	1900	2584	75000	33750	24-196	20-160
L120-420	4200	5712	140000	63000	19-196	16-165
L120-800	8000	10880	250000	112500	12-168	10-140
L120-2000	20000	27200	500000	225000	12-60	10-50

## Maximum stem acceptance

Unit	Threaded Stem Nut		Bore		Keyway		Handwheel Gear Ratio	
	Inch	mm	Inch	mm	Inch	mm	STD	Optional
L120-10	1.25	32	1	25	1/4 x 3/32	8 x 6	1:1	4.2:1
L120-20	2.25	57	1.875	47	1/2 x 3/8	14 x 9	1:1	5.7:1
L120-40	2.625	66	2.125	52	1/2 x 3/8	16 x 10	1:1	12:01
L120-85	3.25	76	2.75	70	5/8 x 7/16	20 x 12	18:1–71:1 (see Note 1)	
L120-190	3.5	89	2.875	73	3/4 x 1/4	20 x 12	22:1	88:1
L120-420	5	127	4.25	108	1 x 3/4	28 x 16	28:1	170:1
L120-800	5	127	7	178	1 x 3/4	32 x 18	NA	24:168
L120-2000	6.25	159	8	203	1-1/4 x 7/8	40 x 22	270:1	772:1

## L120 weights (approx.)

Unit	Actuator		Add for		Add for		Add for		Add for	
	Lbs.	Kg	Lbs.	Kg	Lbs.	Kg	Lbs.	Kg	Lbs.	Kg
L120-10	90	41	20	9	32	14	7	3	3	1
L120-20	115	52	20	9	32	14	13	6	8	4
L120-40	160	72	20	9	32	14	22	10	16	7
L120-85	285	129	20	9	32	14	67	30	(Note 2)	
L120-190	600	272	85	39	(Note 2)		(Note 2)		(Note 2)	
L120-420	1195	541	215	98	(Note 2)		(Note 2)		(Note 2)	
L120-800	1415	641	215	98	(Note 2)		430	195	(Note 2)	
L120-2000	2550	1155	215	98	(Note 2)		826	375	(Note 2)	

Note 1: Same as overall ratio.

Note 2: Consult factory for weight.

Note 3: Performance ratings and dimensions are also available for the L120-6000. Please consult factory.

## Mounting base and drive sleeves

	Previous Designation	Description
Type B4	Drive 1	Bore and key bushing for torque-only applications
Type A1	Drive 2	Threaded for thrust applications
Type BL	Drive 3	Splined steel bushing for rising rotating stem valves

### L120-10, 20 and 40

Drive sleeve	L120-10		L120-20		L120-40	
	inches	mm	inches	mm	inches	mm
Type B4 bore	1.00	24.5	1.88	47.8	2.13	54.1
Type B4 key	1/4 x 3/32		1/2 x 3/16		1/2 x 3/16	
Type B4 stem nut	2.87	73	3.12	79	3.37	86
Type A1 threaded stem	1.25	32.8	2.25	57.2	2.63	66.8
Type A1 stem length	2.83	60	3.25	83	3.86	98
Type BL splined	6 and 38 splines		6 and 38 splines		6 splines	
Type BL spline length	4.5	114	4.5	114	4.5	114

Mounting base	MSS	ISO	MSS	ISO	MSS	ISO
Pilot diameter	2.312	70	3.750	100	3.750	100
Mounting holes (Note 1)	(4)3/8-16x.88	(4)M10x1.5x22.4	(4)5/8-11x1.25	(4)M16x2x32	(4)5/8-11x1.25	(4)M16x2x32
Between centers	4.016	102	5.5	140	5.5	140
Mounting base diameter	4.92	125	7.00	178	7.00	178

### L120-85, 190 and 420

Drive sleeve	L120-85		L120-190		L120-420	
	inches	mm	inches	mm	inches	mm
Type B4 bore	2.75	69.9	2.88	73.2	4.25	108
Type B4 key	5/8 x 7/32		3/4 x 1/4		1 x 3/8	
Type A1 threaded stem	3.0	76	3.5	89	5	127
Type A1 stem length	7	177.8	8.25	209.6	9.38	238.3

Mounting base	MSS	ISO	MSS	ISO	MSS	ISO
Pilot diameter	5	130	7	230	8.5	215.9
Mounting holes (Note 1)	(4)3/4-10x1.0	(4)M20x2.5x26(s)	(8)3/4-10x1.13(s)	(8)M20x2.5x32	(8)7/8-9x1.75	(8)M30x3.5x1.75
Between centers	6.5	165.1	11.75	298	14	355.6
Mounting base diameter	8.25	209.6	13.5	343	16	406.4

### L120-800 and 2000

Drive sleeve	L120-800		L120-2000	
	inches	mm	inches	mm
Type B4 bore	4.5	108	6.25	159
Type B4 key	1 x 1/2	N/A	1.24 x .438	N/A
Type B4 stem nut	11	279.4	12	304.8
Type A1 threaded stem	5	127	6.25	159
Type A1 stem length	2	50.8	3.125	79.4
Type A1 base to drive sl.	15.5	393.7	18.6	472.4

Mounting base	MSS	ISO	MSS	ISO
Pilot diameter	9	300	13	330
Mounting holes (Note 1)	(8)1.25-7x2.00	(8)M36x4x64	(12)15-6x3	N/A
Between centers	16	406	18	457.2
Mounting base diameter	18.8	477.5	21	533.4

Note 1: Mounting holes straddle centerline.

Note 2: L120-85, 190 and 420 are suitable for both torque and thrust applications. L120-800 is suitable for thrust as standard; torque units are optional. L120-2000 is suitable for torque as standard; thrust units are optional.

**L120 actuators offer easy control of all types of valves.**

**Direct mounting** The L120 Series can be directly coupled with valves for torque-only applications. For thrust applications, a separate thrust base is used.

**L120/B320** Rising stem valves may be operated by an L120 coupled to a B320 bevel gear operator. Thrusts up to 325,000 pounds/147,420 Kg and torque up to 12,000 foot pounds/16,270 NM can be accommodated.

**L120/WTR** The L120 Series may be coupled to a WTR worm gear reducer for operation of quarter-turn valves such as butterfly, balls, plugs, and dampers.

**Mounting bases**

**Thrust actuator drive bases**

Type A1 (drive 2)—Alloy bronze (torque and thrust)

**Torque-only actuator bases**

Type B4 (drive 1)—Standard steel bushing

Type BL (drive 3)—Splined steel bushing for rising or rotating stem valves

**Valve mounting options**



L120 mounted to wedge gate

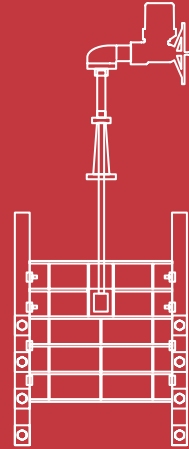

L120/B320 mounted to sluice gate



L120/WTR mounted to butterfly valve



L120/WTR mounted to damper

**Mounting bases (L120-10 through 40)**

**Type A1:** Alloy bronze nut add-on thrust base

**Type B4:** Standard steel bushing add-on torque-only base

**Type BL:** Splined steel bushing add-on torque-only base for rising stem rotating valves



Type B4 (drive 1)



Type A1 (drive 2)



Type BL (drive 3)

**Combinations for torque reduction applications**

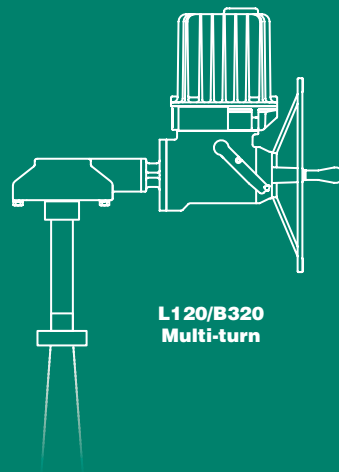

L120/B320 Multi-turn

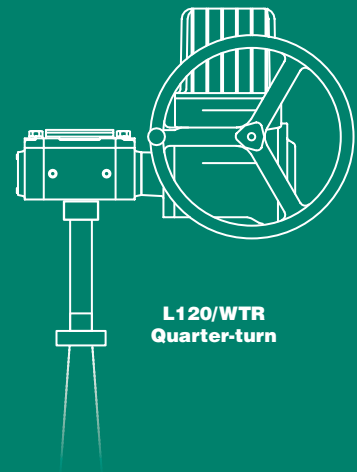

L120/WTR Quarter-turn



## Standard compartment, L120-10 through 40

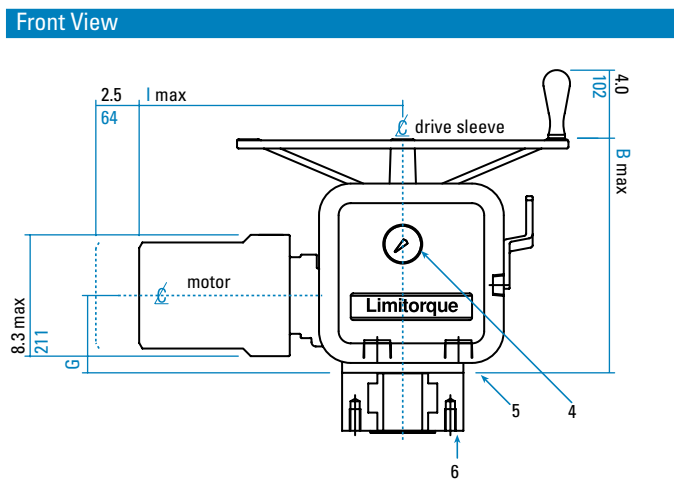
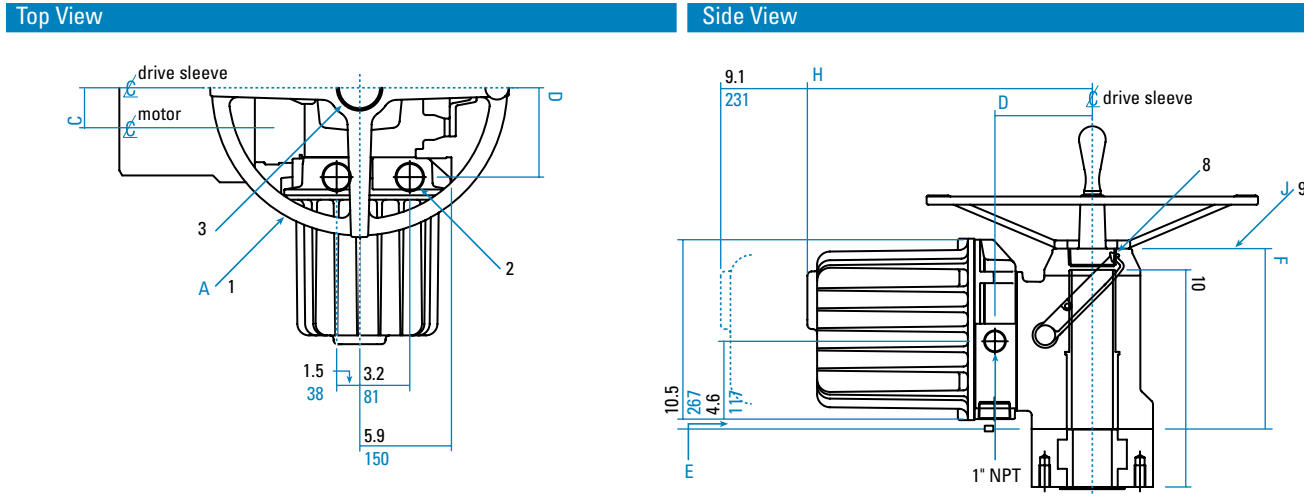

Inches

	A	B	C	D	E	F	G	H	I	J
L120-10	12	12.1	1.6	4.7	1.10	8.5	4.0	15.4	14.2	1.25
L120-20	18	13.6	2.6	5.7	0.51	10.6	4.4	16.4	16.0	2.5
L120-40	24	16.1	2.5	6.2	1.21	12.0	5.2	17.0	18.9	3

Millimeters

	A	B	C	D	E	F	G	H	I	J
L120-10	305	307	41	119	28	216	102	391	361	32
L120-20	457	345	66	145	13	269	112	417	406	64
L120-40	607	409	64	158	30	305	132	432	480	76

Item 1: **A** dimension is the standard diameter handwheel.

Item 2: 1-1/2 NPT (2) places farside.

Item 3: **J** NPT (type A1 (drive 2) only).

Item 4: Position indicator.

Item 5: Mounting base location for types B4 (drive 1) and BL (drive 3).

Item 6: Mounting base location for type A1 (drive 2).

Item 8: Declutch lever is padlockable in motor operation.

Item 9: Reference location of **J** NPT for stem cover.

Item 10: Maximum rising stem without stem cover.

Note: Actuator turns clockwise to close (left hand thread). If other rotation is required, it must be specifically requested.

## Minimum integral compartment, L120-10 through 40

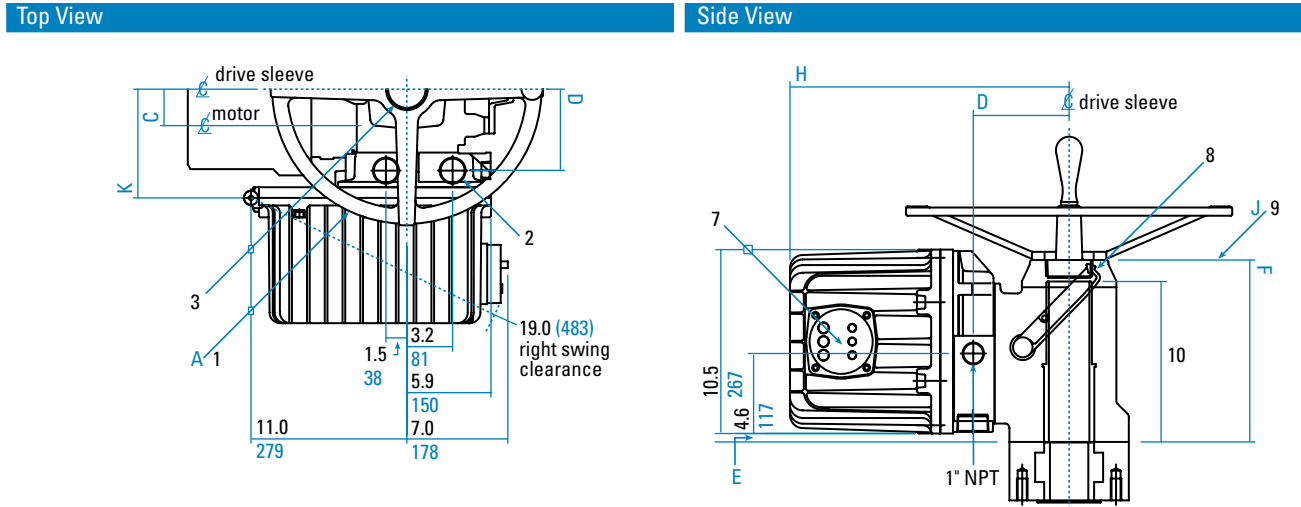

### Front View

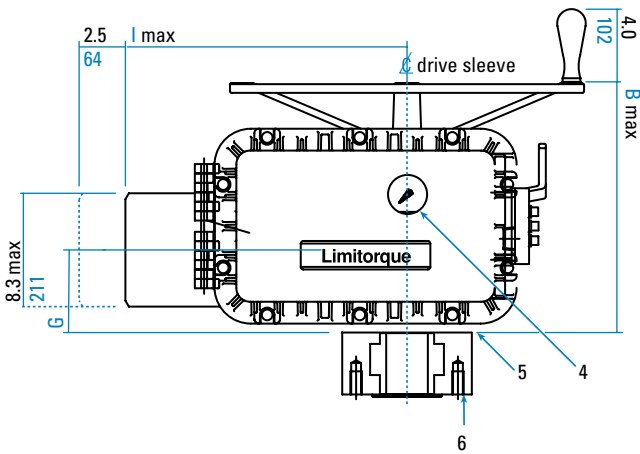

### Inches

	A	B	C	D	E	F	G	H	I	J	K
L120-10	12	12.1	1.6	4.7	1.10	8.5	4.0	15.4	14.2	1.25	6.6
L120-20	18	13.6	2.6	5.7	0.51	10.6	4.4	16.4	16.0	2.5	7.6
L120-40	24	16.1	2.5	6.2	1.21	12.0	5.2	17.0	18.9	3	8.1

### Millimeters

	A	B	C	D	E	F	G	H	I	J	K
L120-10	305	307	41	119	28	216	102	391	361	32	168
L120-20	457	345	66	145	13	269	112	417	406	64	193
L120-40	607	409	64	158	30	305	132	432	480	76	206

Item 1: A dimension is the standard diameter handwheel.

Item 2: 1-1/2 NPT (2) places farside.

Item 3: J NPT (type A1 (drive 2) only).

Item 4: Position indicator.

Item 5: Mounting base location for types B4 (drive 1) and BL (drive 3).

Item 6: Mounting base location for type A1 (drive 2).

Item 7: Pushbutton station control elements. See wiring diagram for quantity and function.

Item 8: Declutch lever is padlockable in motor operation.

Item 9: Reference location of J NPT for stem cover.

Item 10: Maximum rising stem without stem cover.

Note: Actuator turns clockwise to close (left hand thread). If other rotation is required, it must be specifically requested.

## Maximum integral compartment, L120-10 through 40

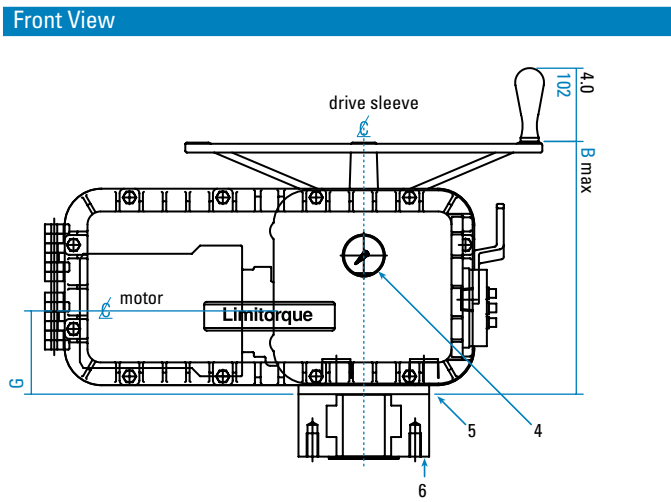
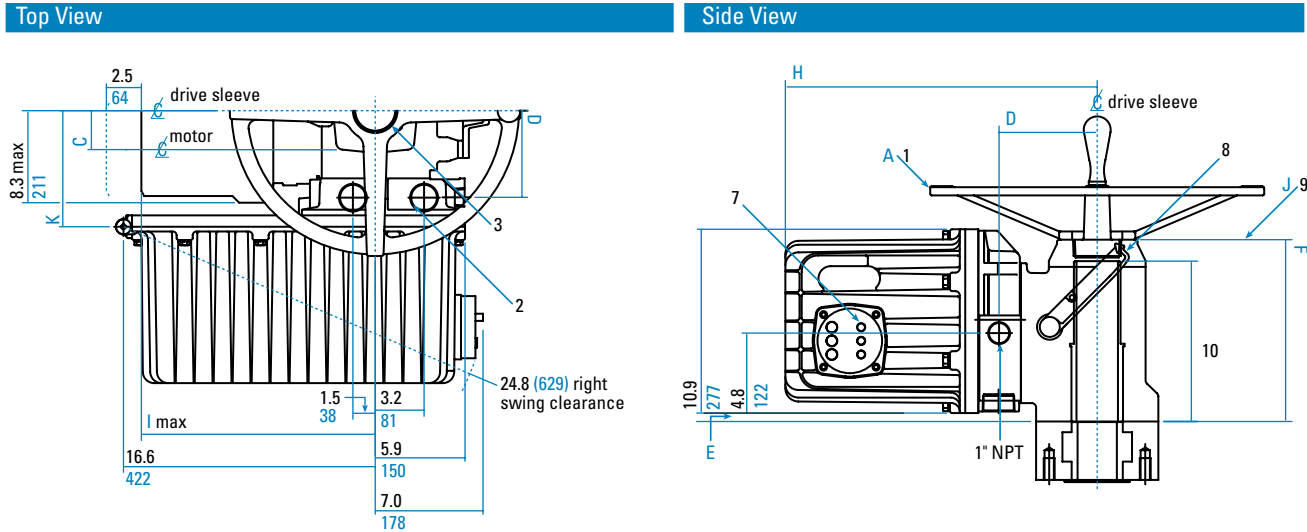

Inches

	A	B	C	D	E	F	G	H	I	J	K
L120-10	12	12.1	1.6	4.7	0.0	8.5	4.0	16.8	14.2	1.25	5.8
L120-20	18	13.6	2.6	5.7	0.35	10.6	4.4	17.8	16.0	2.5	6.8
L120-40	24	14.0	2.5	6.2	1.01	12.0	5.2	18.4	18.9	3	7.4

Millimeters

	A	B	C	D	E	F	G	H	I	J	K
L120-10	305	307	41	119	0	216	102	427	361	32	147
L120-20	457	345	66	145	9	269	112	452	406	64	173
L120-40	610	356	64	158	26	305	132	467	480	76	188

Item 1: **A** dimension is the standard diameter handwheel.

Item 2: 1-1/2 NPT (2) places farside.

Item 3: **J** NPT (type A1 (drive 2) only).

Item 4: Position indicator.

Item 5: Mounting base location for types B4 (drive 1) and BL (drive 3).

Item 6: Mounting base location for type A1 (drive 2).

Item 7: Pushbutton station control elements. See wiring diagram for quantity and function.

Item 8: Declutch lever is padlockable in motor operation.

Item 9: Reference location of **J** NPT for stem cover.

Item 10: Maximum rising stem without stem cover.

Note: Actuator turns clockwise to close (left hand thread). If other rotation is required, it must be specifically requested.



**Minimum Integral Compartment, L120-85 (shown) and 190, MSS (Note 3) and ISO bases (Note 4)**

**Top View**

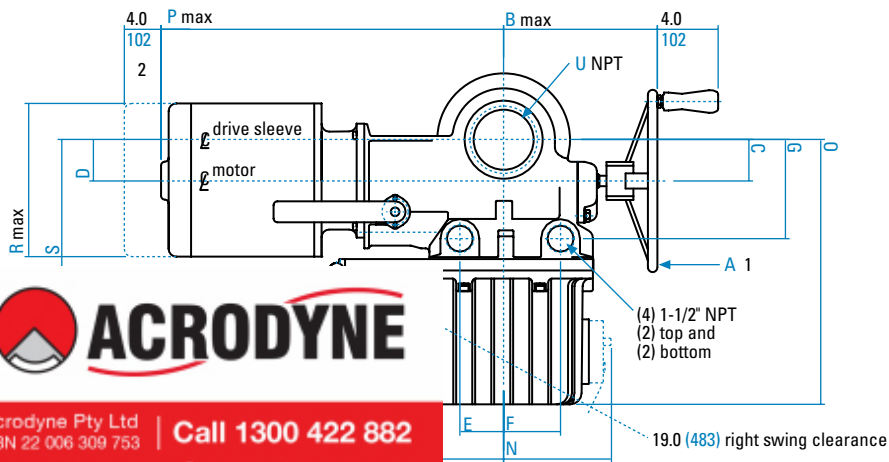

Acrodyne Pty Ltd  
 ABN 22 006 309 753 | Call 1300 422 882  
[www.acrodyne.com.au](http://www.acrodyne.com.au)

**Front View**

**Side View**

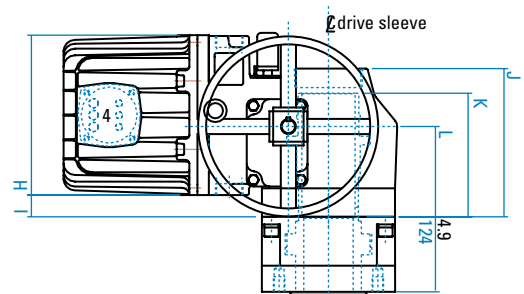
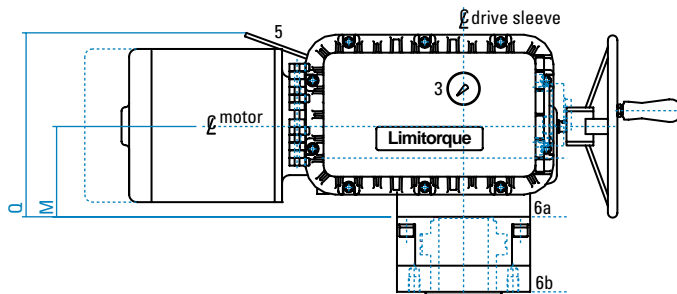

**Inches**

	A	B	C	D	E	F	G	H	I	J	K	L	M	N	O	P	Q	R	S	T	U
L120-85	12	10.1	2.7	2.7	2.8	3.8	6.5	10.5	1.4	9.8	8.1	5.9	5.9	7.0	17.4	25.7	12.1	10.5	8.6	11.0	4
L120-190	18	15.5	4.4	4.4	5.1	5.5	8.2	10.8	0.8	13.3	11.1	8.3	6.6	5.5	18.1	32.2	14.7	12.5	9.6	8.0	5

**Millimeters**

	A	B	C	D	E	F	G	H	I	J	K	L	M	N	O	P	Q	R	S	T	U
L120-85	305	257	69	69	71	97	165	267	36	249	206	150	150	179	442	653	307	267	218	279	102
L120-190	457	394	112	112	130	140	208	274	20	338	282	209.6	168	140	460	818	373	318	244	203	127

- Item 1: A dimension is the standard diameter handwheel.
- Item 2: Space for motor removal.
- Item 3: Position indicator.
- Item 4: Pushbutton station control elements. See wiring diagram for quantity and function.
- Item 5: Declutch lever is padlockable in motor operation.
- Item 6a (L120-85 only): Mounting location for base type BL (drive 1).
- Item 6b (L120-85 only): Mounting location for base type A1 (drive 2).
- Note 1: Actuator turns clockwise to close (left hand thread). If other rotation is required, it must be specifically requested.
- Note 2: Larger units are also available (L120-420, 800, and 2000). Above drawings may apply with some variations.
- Note 3: Provided with NPT taps and imperial dimensions per MSS standard.
- Note 4: Provided with metric taps and dimensions per ISO standard.

# Limitorque

Australian Distributor for Limitorque

