

# PEAKTRONICS

## SVC-102

### Solenoid Valve Controller

The Peaktronics SVC-102 Solenoid Valve Controller is a compact module that is intended for controlling pneumatic or hydraulic actuators. The SVC-102 is very well suited for applications where space is at a minimum.

The SVC-102 is used for proportional positioning of the actuator. An external command signal of 0-5V, 0-10V, 4-20mA, or 1-5V is compared to a feedback signal from a potentiometer. This in turn will energize one of the AC outputs (*open* or *close*) to power an AC solenoid valve (up to 2A), which then moves the actuator until the feedback signal matches the command signal. At that time, the controller's AC output is turned off and the actuator stops. If the command signal is lost or disconnected, the unit interprets this as a zero command signal, and therefore moves the actuator to the position associated with the zero adjustment.

Non-interactive Zero and Span adjustments allow easy field calibration, and the Deadband adjustment allows control of faster actuators. The unit includes a red LED indicator (for the *open* output), a green LED (for the *close* output), and an on-board replaceable fuse.

The unit is available in versions for 117VAC  $\pm 10\%$  (SVC-102), 234VAC  $\pm 10\%$  (SVC-102A), and 24VAC  $\pm 10\%$  (SVC-102B) and provides optical isolation between the input signal and the AC outputs. Its solid construction body makes it rugged and easy to mount (two #6 through holes are provided). Screw terminals and a wiring diagram on the unit allow for easy field installation.

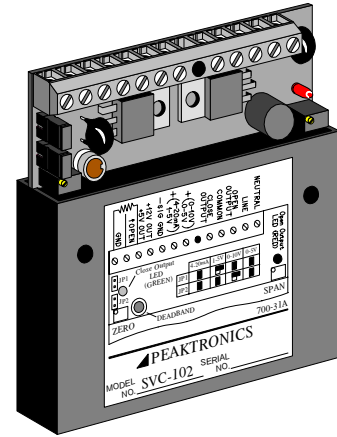

SVC-102  
SVC-102A  
SVC-102B

## ADDITIONAL FEATURES

- Miniature size fits in the smallest actuators.
- +12V output for powering a command input 4-20mA transmitter, or a position feedback transmitter (either 4-20mA or 0-5/10V).
- Operating temperature range of 0 to 60°C

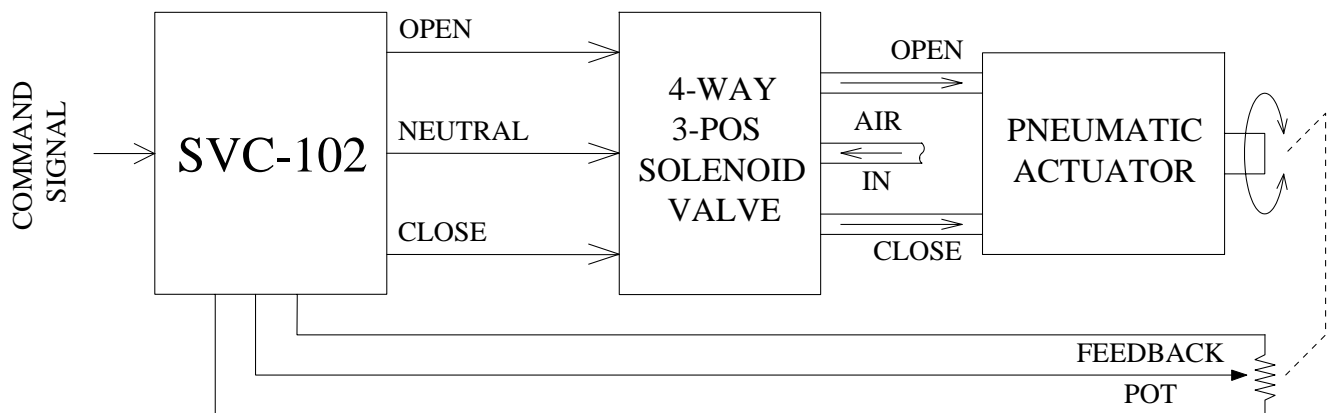

TYPICAL PNEUMATIC MODULATING ACTUATOR

# OUTLINE

SVC-102 117VAC  
 SVC-102A 234VAC  
 SVC-102B 24VAC

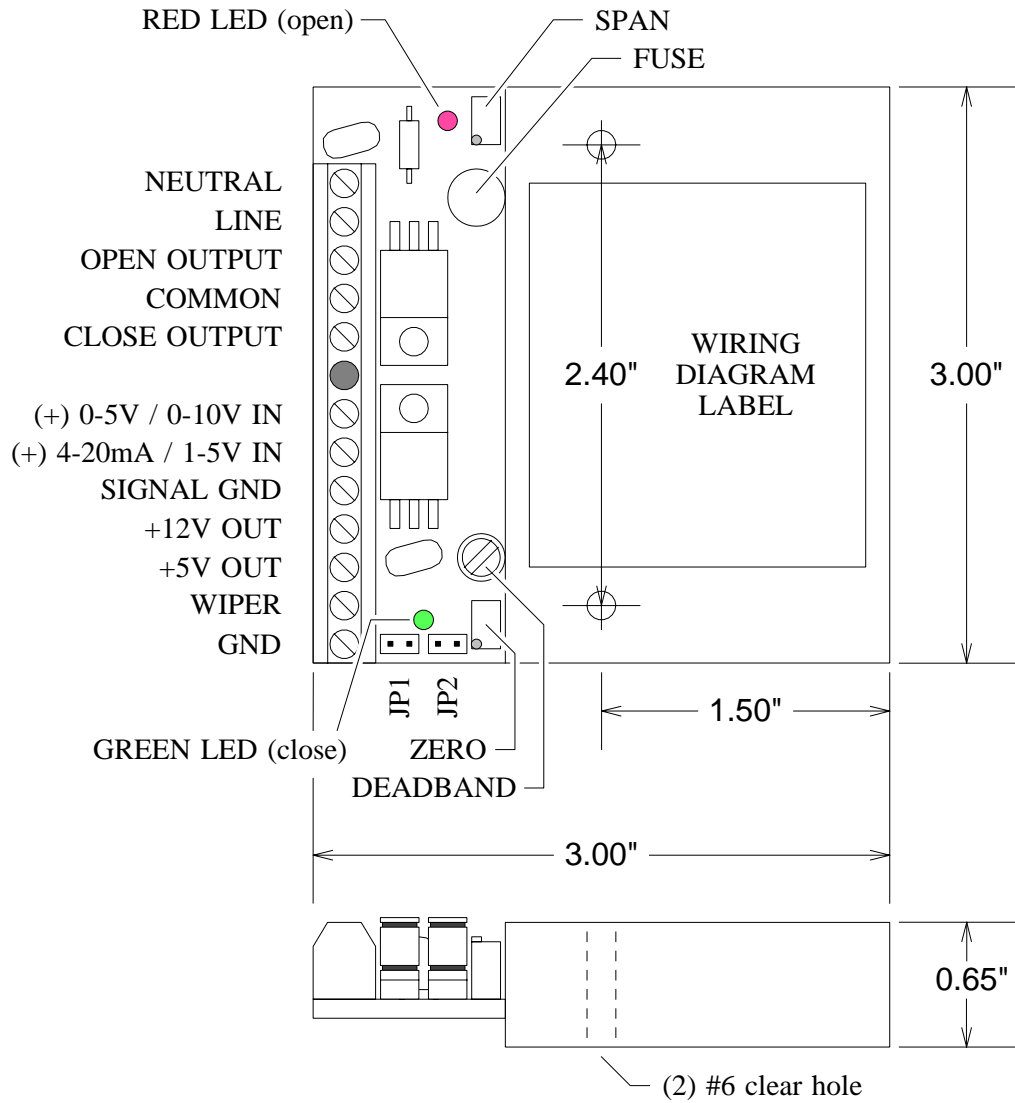

INPUT SIGNAL		
INPUT SIGNAL RANGE	JP1	JP2
0-5V	■	■
0-10V	■	□■
4-20mA	■	■
1-5V	■□	■

## BLOCK DIAGRAM

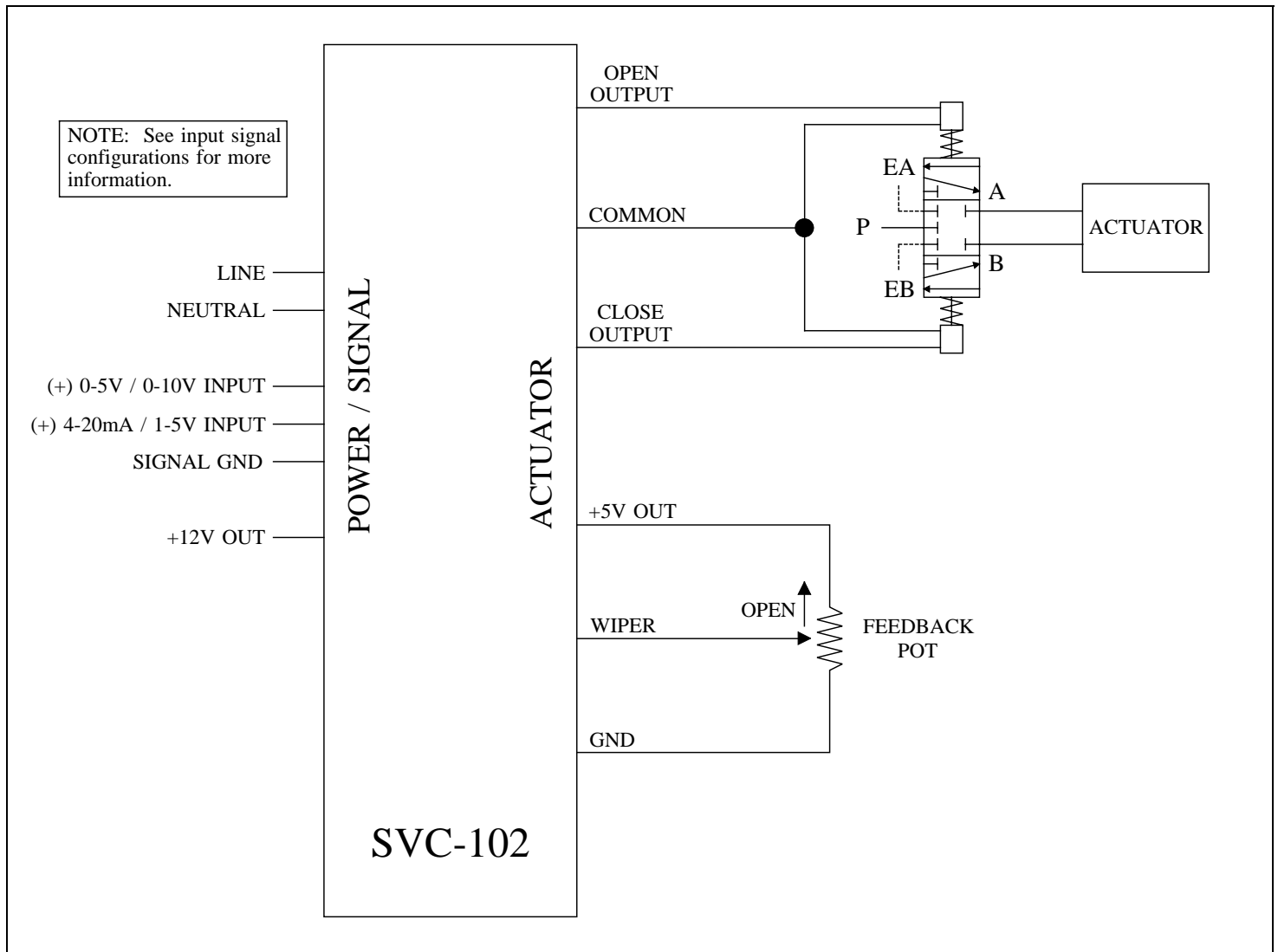

## DESCRIPTION

The SVC-102 comes in three versions to accommodate different voltage applications. The SVC-102 is rated for 117 VAC  $\pm 10\%$ ; the SVC-102A is rated for 234 VAC  $\pm 10\%$ , and the SVC-102B is rated for 24 VAC  $\pm 10\%$ . The unit is equipped with screw terminals, allowing for easy field wiring. The unit also has a label that provides convenient information for wiring and locating the adjustments. Two mounting holes are provided that allow easy mounting with standard #6 screws. See Outline information for more details.

**CAUTION !** These units are intended to be mounted in an appropriate enclosure to avoid electrical shocks. High voltages are present on the outside of the unit when power is applied. AC power should be disconnected prior to any wiring of these units. A heater and thermostat should be used where condensation may occur.

## POWER

Power is connected to the terminals marked LINE and NEUTRAL. The unit does not have an earth ground connection; earth ground should be connected to the body of the actuator. The fuse installed on the unit is rated for maximum output current that can be safely delivered by the solenoid outputs. Replacement fuses must not exceed the maximum rating of 2A in order to prevent damage to the unit.

## SOLENOIDS and FEEDBACK POT

The solenoids and feedback potentiometer are connected as shown in the block diagram. The OPEN terminal should be connected to the solenoid that moves the actuator toward the *open* position, and conversely, the CLOSED terminal is connected to the solenoid that moves the actuator toward the *closed* position. The COMMON terminal is the neutral or common wire to both solenoids. These outputs are also suitable for driving relays which in turn can control various types of motors (see Wiring Diagrams). However, these outputs **cannot** drive motors directly - damage to the unit may occur!

The feedback potentiometer wiper must be connected to the WIPER terminal. One end of the potentiometer is connected to the +5V OUT terminal, and the other is connected to the GND terminal. The potentiometer should be connected so that when the actuator moves towards the *open* position, the potentiometer's resistance between the WIPER and GND terminals will increase. This can also be measured as a voltage - the voltage between the WIPER and GND terminals should increase when the actuator moves towards the *open* position. If the potentiometer is wired incorrectly, the typical response of the unit will be to run the actuator to the full open or closed position, regardless of the command signal input, and the corresponding output indicator remains on.

The feedback potentiometer should be mounted to provide a proper feedback signal through the entire range between the *open* and *closed* positions. For best results, position the actuator to the midway point between the *open* and *closed* positions; then adjust the feedback potentiometer for approximately 2.5 VDC (or 1/2 of the potentiometer's resistance) between the WIPER and GND terminals.

Since the feedback potentiometer is crucial for proper operation of the SVC-102, the following items should be carefully observed:

- 1 - Potentiometer resistance should be a value from 1K to 10K ohms.

- 2 - The potentiometer should be a linear taper type.
- 3 - The potentiometer must be properly wired to provide the correct feedback signal.
- 4 - The potentiometer must be properly and securely mounted in order to provide a reliable feedback signal.

## COMMAND SIGNAL

An appropriate command signal, either 0-5V, 0-10V, 4-20mA, or 1-5V, should be connected to the appropriate terminal (as shown in the Block Diagram) while using the SIGNAL GND terminal as the return *signal ground*. The SVC-102 must be configured for the type of command signal that is to be used. Jumper plugs JP1 and JP2 should be properly installed (as shown in the Outline) prior to operating the unit.

## +12V OUT

The +12V OUT terminal provides an auxiliary +12VDC output that can be used to power a command input 4-20mA transmitter, or a position feedback transmitter (either 4-20mA or 0-5/10V). Note that only one transmitter can be powered by the SVC-102. When powering a 4-20mA transmitter with the +12V OUT, care should be taken to insure that the total resistance of all devices connected in the 4-20mA loop does not exceed 300 ohms. See Wiring Diagrams for various applications.

## OUTPUT INDICATORS

The SVC-102 has on-board indicators that identify when one of the solenoid outputs is turned on. When the open output is turned on, the red LED indicator will turn on, and when the close output is turned on the green LED indicator will turn on (see Outline).

It is possible that the SVC-102 will indicate that one of the solenoid outputs is turned on when the actuator is not in motion. This occurs when the actuator reaches its mechanical limit before attaining the position represented by the command signal. However, it should be noted that when the indicator is on, power is applied to the solenoid output.

## CALIBRATION

The non-interactive zero and span adjustments of the SVC-102 allows for easy calibration once the unit is installed. After insuring that the solenoid outputs and feedback potentiometer are wired to provide a proper feedback signal, as described under "SOLENOIDS and FEEDBACK POT", follow these steps to calibrate the unit (see Outline for the location of the adjustments):

- 1 - Apply AC power to the unit, and set the command input signal to minimum:

0V for 0-5V input type  
 0V for 0-10V input type  
 1V for 1-5V input type  
 4mA for 4-20mA input type

- 2 - Adjust the "Zero" adjustment so that the actuator moves to the desired *closed* position. If the desired position cannot be achieved, check that the feedback potentiometer provides a feedback signal as described under "SOLENOIDS and FEEDBACK POT".
- 3 - If the actuator is hunting for position, turn the "Deadband" adjustment clockwise until hunting stops. If the actuator is not hunting for position, turn the "Deadband" adjustment counterclockwise until the actuator begins to hunt; then turn the "Deadband" adjustment slightly clockwise until hunting stops.

**WARNING!** Actuator, solenoid, or feedback potentiometer failure may occur if the "Deadband" adjustment is set to allow continuous hunting. This can cause excessive wear of all moving mechanical parts. Hunting can also cause the solenoids to become hot and thereby raising internal temperatures of the solenoid coils beyond their rated limit. Note that the maximum operating temperature of the SVC-102 is 60°C.

- 4 - Set the command signal input to maximum:

5V for 0-5V input type  
 10V for 0-10V input type  
 5V for 1-5V input type  
 20mA for 4-20mA type

- 5 - Adjust the "Span" adjustment so that the actuator moves to the desired *open* position. If the desired position cannot be achieved, check that the feedback potentiometer is able to provide an appropriate signal.

**NOTE:** The "Zero" adjustment is an offset setting rather than an absolute setting. Should the "Zero" adjustment be changed, the "Span" adjustment should be checked for the desired *open* position. Setting of the "Span" adjustment has no affect on the "Zero" adjustment.

- 6 - To check proper operation and linearity, set the command signal to halfway:

2.5V for 0-5V input type  
 5V for 0-10V input type  
 3V for 1-5V input type  
 12mA for 4-20mA input type

Verify that the actuator's position is midway between the *open* and *closed* positions.

## REVERSE ACTING CALIBRATION

When converting a direct acting actuator to a reverse acting actuator, two changes in wiring must be made:

- 1 - Reverse the feedback potentiometer wires connected to +5V OUT and GND.
- 2 - Reverse the solenoid output wires connected to OPEN OUTPUT and CLOSE OUTPUT.

**NOTE: DO NOT** reverse the input signal polarity. Also, make sure that both wiring changes are made - if only one is made, the actuator will run to either full *open* or full *closed*.

After the wiring changes have been made, refer to **CALIBRATION** for setting the zero and span adjustments.

## SPECIFICATIONS

### POWER REQUIREMENTS

SVC-102: 117VAC  $\pm 10\%$ , 50/60 Hz  
SVC-102A: 234VAC  $\pm 10\%$ , 50/60 Hz  
SVC-102B: 24VAC  $\pm 10\%$ , 50/60 Hz  
12 VA typical (not including output load)  
Fuse Type: 2A TR5 Slo-Blo (replaceable)

### COMMAND SIGNAL INPUT

Input Impedance  
0-5 VDC Input: 5K ohms  
0-10 VDC Input: 10K ohms  
4-20 mA Input: 250 ohms  $\pm 1\%$   
1-5 VDC Input: 1M ohms minimum

### FEEDBACK SIGNAL INPUT

Input Voltage: 0 to 5 VDC  
External Feedback Potentiometer: 1K ohm to 10K ohms

### +12V OUTPUT

12VDC @ 15mA maximum  
10VDC @ 28mA maximum

### SOLENOID OUTPUTS

Off-state Leakage Current:  $< 5\text{mA}$   
Maximum Load Current @ 60°C: 2A

### CONTROL ADJUSTMENTS

Zero: adjustable throughout feedback signal range  
Span: adjustable throughout command signal range  
Deadband: adjustable from 0.12% to 2.1% of full feedback range

### ENVIRONMENTAL

Operating Temperature Range: 0 °C to 60 °C  
Storage Temperature Range: -40 °C to 85 °C  
Relative Humidity Range: 0 to 90 % (noncondensing)

## WIRING DIAGRAMS

### Input Signal Configurations

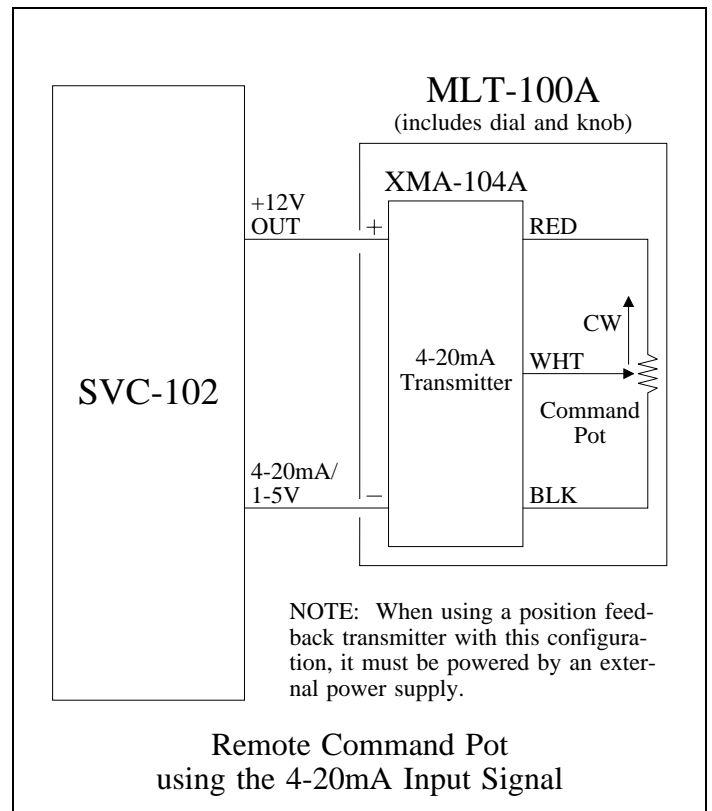
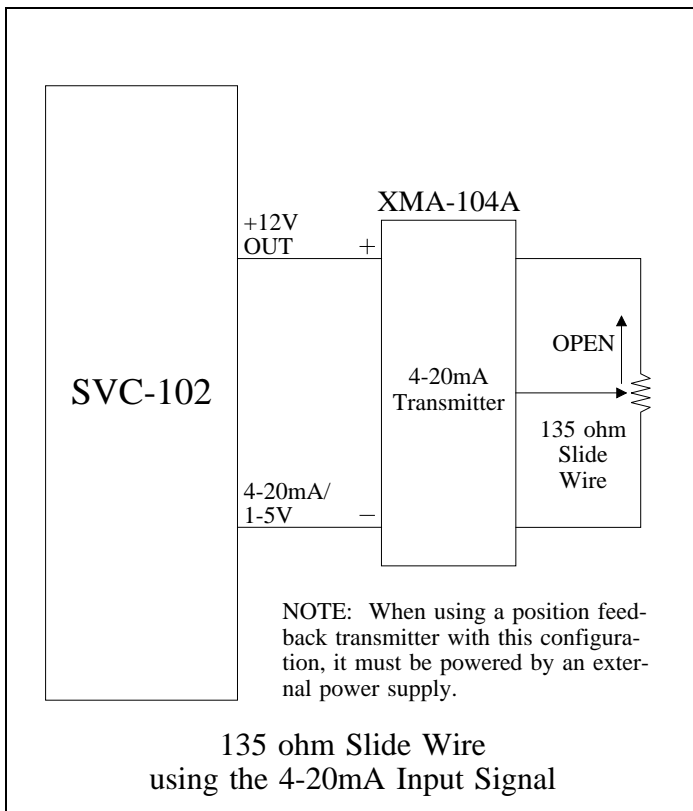
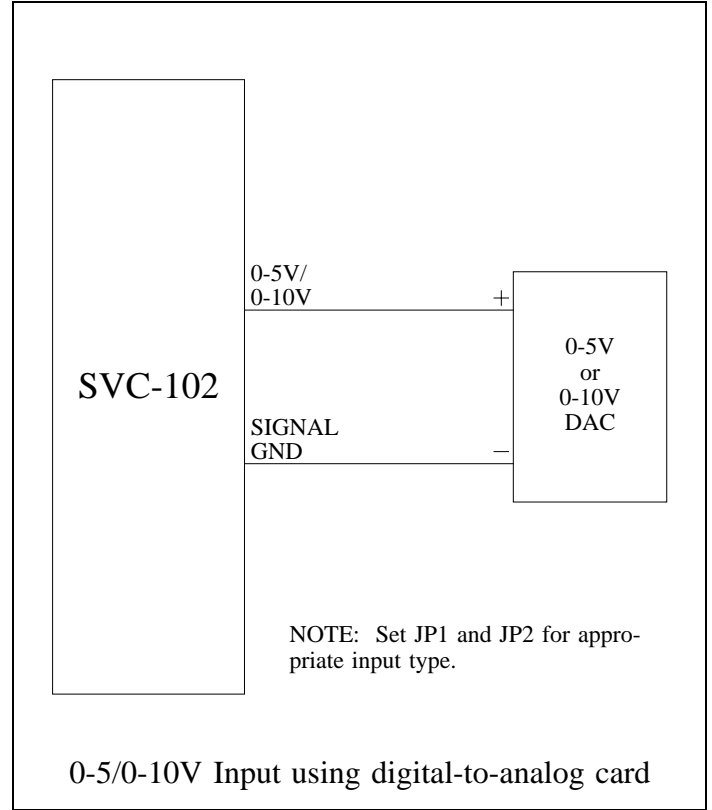
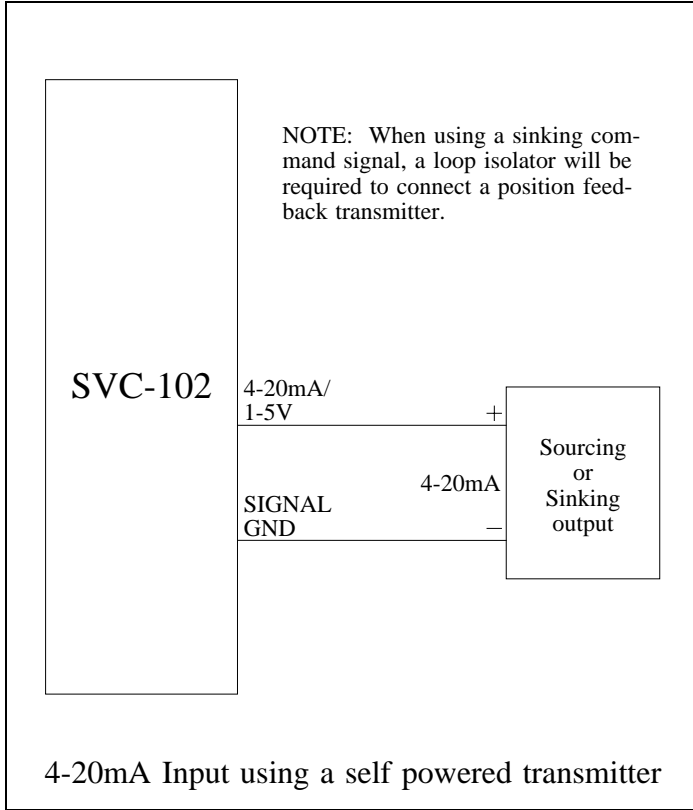

## WIRING DIAGRAMS

### Special Applications

