

▲ PEAKTRONICS

SVC-100

Solenoid Valve Controller

The Peaktronics SVC-100 Solenoid Valve Controller is used to provide proportional positioning of pneumatic actuators by controlling two external AC solenoid valves, which in turn control the air to the *open* and *close* ports on the actuator. An external command signal of 0-10V, 1-5V, or 4-20mA is used to compare to a feedback signal from a potentiometer. The *open* or *closed* AC output will energize, which powers the appropriate solenoid, until the feedback signal matches the command signal, at which time the controller's AC output is turned off and the actuator stops.

With a loss of command signal in the 1-5V or the 4-20mA input range, the SVC-100 offers three useful options: fail-in-place, *open* output on, or *closed* output on. All input and output options are easily field configurable with jumper plugs. The only other adjustments consist of Deadband and non-interactive Zero and Span trimmers, which allows for easy field calibration.

The SVC-100 is available in versions for 117VAC $\pm 10\%$, 234VAC $\pm 10\%$, or 24VAC $\pm 10\%$ power and gives the user optical isolation between the input signal and the AC outputs. The unit includes a red LED indicator (for the *open* output), a green LED indicator (for the *close* output), an on-board fuse, and two removable screw terminal strips (for easy servicing).

The SVC-100 (117VAC), SVC-100B (234VAC), and SVC-100D (24VAC) come mounted on Snaptrack[®]. The SVC-100A (117VAC), SVC-100C (234VAC), and SVC-100E (24VAC) come with standoff mounts for direct mounting to a subplate or bracket; each unit also includes an insulating sheet.

Snaptrack[®] is a registered trademark of Augat/RDI.

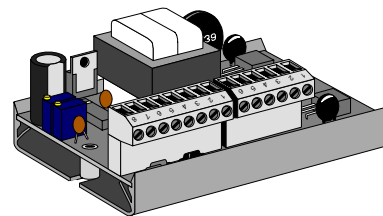

SVC-100
SVC-100B
SVC-100D

SVC-100A
SVC-100C
SVC-100E

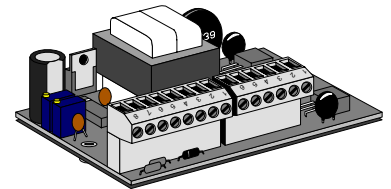

ADDITIONAL FEATURES

- Multiple units are easily connected in parallel to a common command signal.
- Built-in utility power supplies for powering a command pot, 4-20mA input or output transmitter, and the feedback potentiometer.

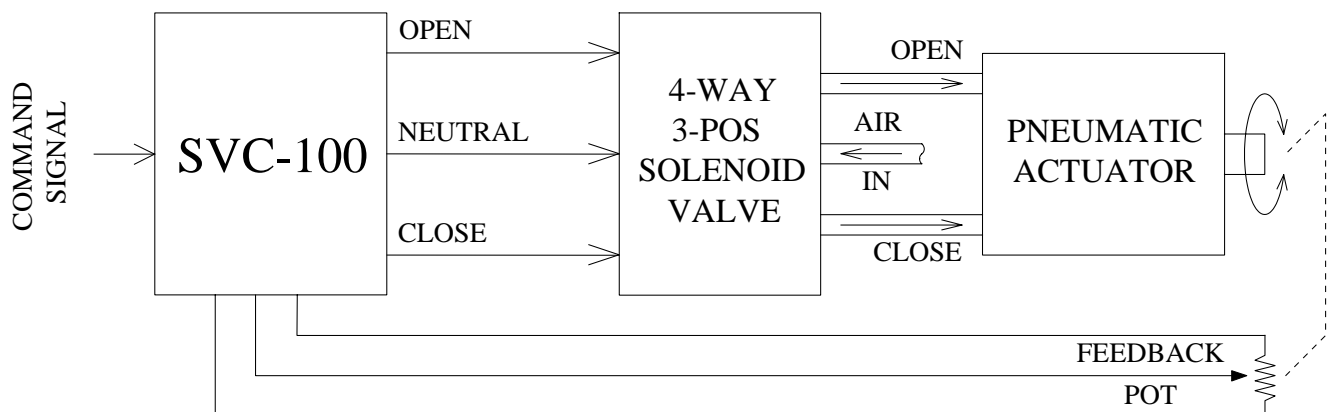

TYPICAL PNEUMATIC MODULATING ACTUATOR

OUTLINE

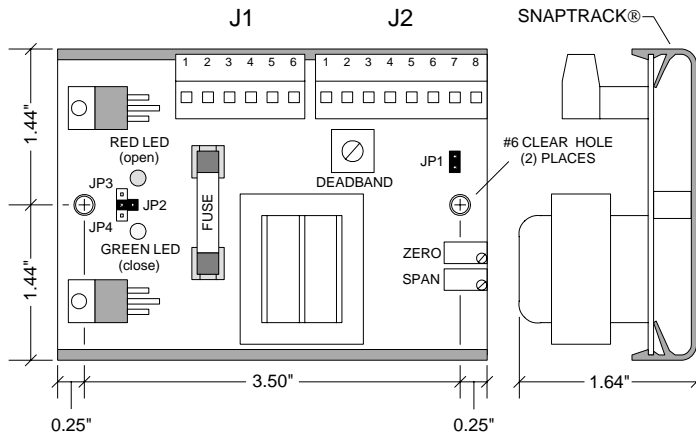

SVC-100 117VAC
SVC-100B 234VAC
SVC-100D 24VAC

ELECTRICAL CONNECTIONS

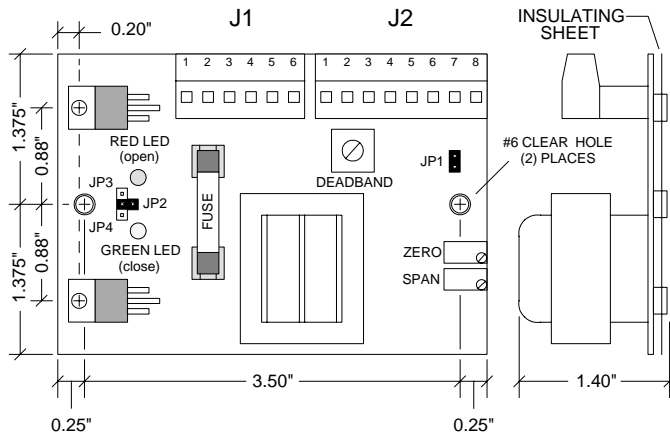
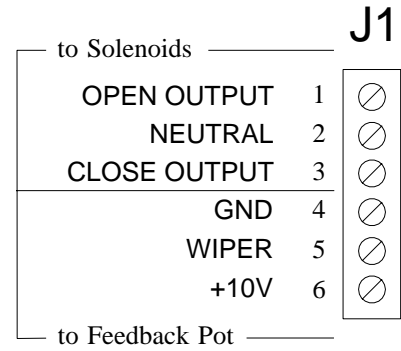

SVC-100A 117VAC
SVC-100C 234VAC
SVC-100E 24VAC

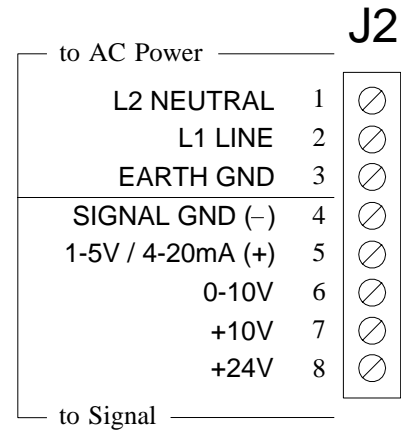

INPUT SIGNAL	
INPUT SIGNAL RANGE	JP1 JUMPER PLUG
0-10V	INSTALL
1-5V	REMOVE
4-20mA	INSTALL

LOSS OF INPUT SIGNAL	
OUTPUT STATE	JUMPER PLUG
BOTH OFF	JP2
OPEN ON	JP3
CLOSE ON	JP4

NOTE: Do not install JP2, JP3, or JP4 when using the 0-10V input signal range.

BLOCK DIAGRAM

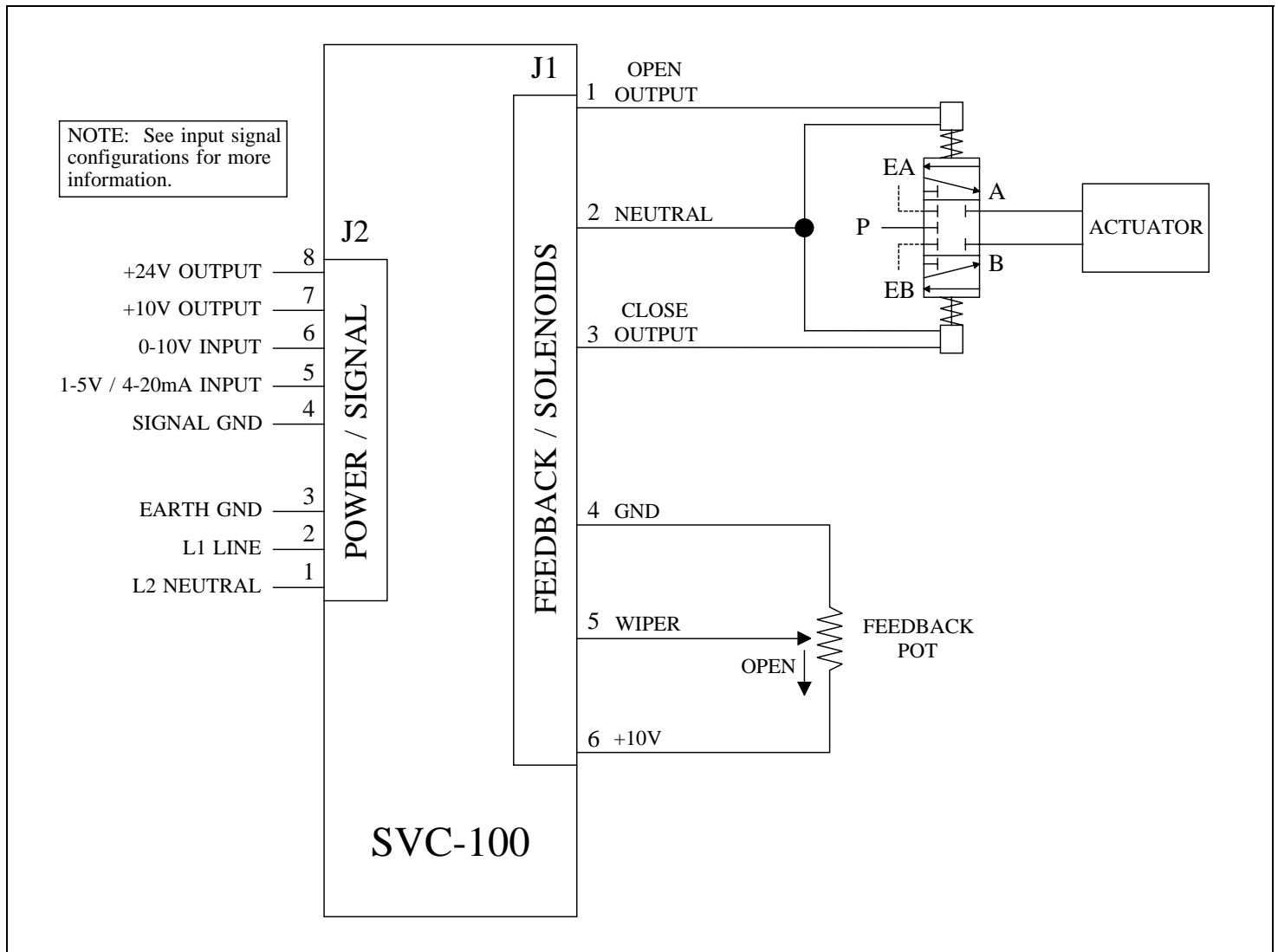

DESCRIPTION

The SVC-100 Solenoid Valve Controller comes in different configurations to suit various applications. The SVC-100 (117VAC), the SVC-100B (234VAC), and the SVC-100D (24VAC) are mounted on snaptrack which allows for easy mounting into electrical enclosures. The SVC-100A (117VAC), the SVC-100C (234VAC), and the SVC-100E (24VAC) have standoffs for direct mounting to a bracket (insulating sheet is included).

The SVC-100 is intended to operate two external solenoid valves which control the air supply to the open and close ports of a pneumatic actuator. A command signal of either 0-10V, 1-5V, or 4-20mA is used to control the position of the actuator shaft. A feedback potentiometer is used

to track the position of the actuator shaft, and in turn the SVC-100 will turn on the appropriate solenoid output in order to maintain the position dictated by the command signal.

While the unit is intended for use with solenoid valves, the SVC-100 is also suitable for controlling relays which in turn can control either DC motors, AC motors, or even 3-phase AC motors (see Wiring Diagrams for details).

CAUTION ! The SVC-100 is intended to be mounted in an appropriate enclosure to avoid electrical shocks. AC power should be removed prior to any wiring of the unit, and a heater and thermostat should be used where condensation may occur.

POWER / SIGNAL (J2)

Power is connected to pins 1, 2, and 3 as shown in the block diagram. The 2A on-board fuse is rated for maximum output current that can be safely delivered by the solenoid outputs. Replacement fuses must not exceed this rating in order to avoid damage to the unit.

An appropriate command signal, either 0-10V, 1-5V, or 4-20mA, should be connected to pin 5 or 6 (as shown in the Block Diagram) while using pin 4 as the return *signal ground*. The SVC-100 must be configured for the type of command signal that is to be used - jumper plug JP1 must be installed whenever a 4-20mA or 0-10V input is used (see Outline).

Pin 7 of J2 provides an auxiliary +10V output which can be used to connect a command potentiometer. By connecting one end of a potentiometer to pin 7, the other end to pin 4, and the wiper to pin 6, a local control knob can be implemented. Pin 8 provides an auxiliary +24VDC output which can be used to power an input or output 4-20mA transmitter.

FEEDBACK / SOLENOIDS (J1)

The solenoids and feedback potentiometer are connected to J1 as shown in the block diagram. Pin 1 should be connected to the solenoid valve that moves the actuator toward the *open* position, and conversely, pin 3 is connected to the solenoid valve that moves the actuator toward the *closed* position. Pin 2 is the neutral or common wire to both solenoids. These outputs are also suitable for driving relays which in turn can control various types of motors (see Wiring Diagrams). However, these outputs **cannot** drive motors directly - damage to the unit may occur!

The feedback potentiometer wiper must be connected to pin 5 of J1. One end of the potentiometer is connected to pin 4, and the other is connected to pin 6. The potentiometer should be connected so that when the actuator moves towards the *open* position, the potentiometer's resistance between pins 4 and 5 will increase. This can also be measured as a voltage - the voltage between pins 4 and 5 should increase when the actuator moves towards the *open* position. If the potentiometer is wired incorrectly, the typical response of the unit will be to run the actuator to the full open or closed position (the appropriate output indicator will remain on) regardless of the command signal input.

The feedback potentiometer should be mounted to provide a proper feedback signal through the entire range between the *open* and *closed* positions. For best results, position the actuator to the midway point between the *open* and *closed* positions; then adjust the feedback potentiometer for approximately 5VDC (or 1/2 of the potentiometer's resistance) between pins 4 and 5 of J1.

Since the feedback potentiometer is crucial for proper operation of the SVC-100, the following items should be carefully observed:

- 1 - Potentiometer resistance should be a value from 1K to 10K ohms.
- 2 - The potentiometer should be a linear taper type.
- 3 - The potentiometer must be properly wired to provide the correct feedback signal.
- 4 - The potentiometer must be properly and securely mounted in order to provide a reliable feedback signal.

OUTPUT INDICATORS

The SVC-100 has on-board indicators that identify when one of the solenoid outputs is turned on. When the open output is turned on, the red LED indicator will turn on, and when the close output is turned on the green LED indicator will turn on (see Outline).

It is possible that the SVC-100 will indicate that one of the solenoid outputs is turned on when the actuator is not in motion. This occurs when the actuator reaches its mechanical limit before attaining the position represented by the command signal. However, it should be noted that when the indicator is on, power is applied to the solenoid output.

LOSS OF INPUT SIGNAL

When the 1-5V or 4-20mA type command signal is used, the SVC-100 can detect that the input signal has been disconnected. The unit can be configured to respond to the loss of command signal in one of three ways: turn both outputs off (to remove the air supply to the actuator), turn on the open output (to move the actuator to the full *open* position), or turn on the close output (to move the actuator to the full *closed* position). To select the desired response to a loss of input signal, install jumper plug JP2, JP3, or JP4 as shown in the Outline information. Power should be disconnected when installing or removing these jumpers.

For applications using the 0-10V input signal type, the unit **cannot** detect a loss of signal. **Do not** install jumper plugs JP2, JP3, and JP4 for these applications.

CALIBRATION

The non-interactive zero and span adjustments of the SVC-100 allow for easy calibration once the unit is installed. After insuring that the feedback potentiometer and solenoid outputs are wired to provide a proper feedback signal, as described under "FEEDBACK / SOLENOIDS (J1)", follow these steps to calibrate the unit (see Outline for the location of the adjustments):

- 1 - Apply AC power to the unit, and set the command input signal to minimum:

0V for 0-10V input type
 1V for 1-5V input type
 4mA for 4-20mA input type

- 2 - Adjust the "Zero" adjustment so that the actuator moves to the desired *closed* position. If the desired position cannot be achieved, check that the feedback potentiometer provides a feedback signal as described under "FEEDBACK / SOLENOIDS (J1)".
- 3 - If the actuator is hunting for position, turn the "Deadband" adjustment clockwise until hunting stops. If the actuator is not hunting for position, turn the "Deadband" adjustment counterclockwise until the actuator begins to hunt; then turn the "Deadband" adjustment slightly clockwise until hunting stops.

WARNING! Actuator, solenoid, or feedback potentiometer failure may occur if the "Deadband" adjustment is set to allow continuous hunting. This can cause excessive wear of all moving mechanical parts. Hunting can also cause the solenoids to become warm and thereby raising internal temperatures of the enclosure housing the solenoids. Note that the maximum operating temperature of the SVC-100 is 60°C.

- 4 - Set the command signal input to maximum:

10V for 0-10V input type
 5V for 1-5V input type
 20mA for 4-20mA type

- 5 - Adjust the "Span" adjustment so that the actuator moves to the desired *open* position. If the desired position cannot be achieved, check that the feedback potentiometer is able to provide an appropriate signal.

NOTE: The "Zero" adjustment is an offset setting rather than an absolute setting. Should the "Zero" adjustment be changed, the "Span" adjustment should be checked for the desired *open* position. Setting of the "Span" adjustment has no affect on the "Zero" adjustment.

- 6 - To check proper operation and linearity, set the command signal to halfway:

5V for 0-10V input type
 3V for 1-5V input type
 12mA for 4-20mA input type

Verify that the actuator's position is midway between the *open* and *closed* positions.

REVERSE ACTING CALIBRATION

When converting a direct acting actuator to a reverse acting actuator, two changes in wiring must be made:

- 1 - Reverse the feedback potentiometer wires connected to J1-4 and J1-6.
- 2 - Reverse the motor output wires connected to J1-1 and J1-3.

NOTE: DO NOT reverse the input signal polarity. Also, make sure that both wiring changes are made - if only one is made, the actuator will run to either full *open* or full *closed*.

After the wiring changes have been made, refer to **CALIBRATION** for setting the zero and span adjustments.

SPECIFICATIONS

POWER REQUIREMENTS

SVC-100, SVC-100A: 117VAC \pm 10%, 50/60 Hz
SVC-100B, SVC-100C: 234VAC \pm 10%, 50/60 Hz
SVC-100D, SVC-100E: 24VAC \pm 10%, 50/60 Hz
3.6 VA typical (not including output load)
Fuse Type: 2A 3AG Slo-Blo

COMMAND SIGNAL INPUT

0-10 VDC Input
Input Impedance: 11K ohms minimum
External Command Potentiometer: 1K ohm
1-5 VDC Input
Input Impedance: 1M ohms minimum
Loss of Command Signal Threshold: \leq 0.75V
4-20 mA Input
Input Impedance: 250 ohms \pm 1%
Loss of Command Signal Threshold: \leq 3mA

FEEDBACK SIGNAL INPUT

Input Voltage: 0 to 10 VDC
External Feedback Potentiometer: 1K ohm to 10K ohms

POWER SUPPLY OUTPUTS

Input or Output Transmitter Power (J2-8): 24VDC @ 20mA max
Command Signal Potentiometer Power (J2-7): 10VDC @ 10mA max
NOTE: *Do not* connect these outputs to other power supplies.

SOLENOID OUTPUTS

Off-state Leakage Current: $<$ 5mA
Maximum Load Current @ 60°C: 2A

CONTROL ADJUSTMENTS

Zero: adjustable throughout feedback signal range
Span: adjustable throughout command signal range
Deadband: adjustable from 0.12% to 2.4% of span

ENVIRONMENTAL

Operating Temperature Range: 0 °C to 60 °C
Storage Temperature Range: -40 °C to 85 °C
Relative Humidity Range: 0 to 90 % (noncondensing)

WIRING DIAGRAMS

Input Signal Configurations

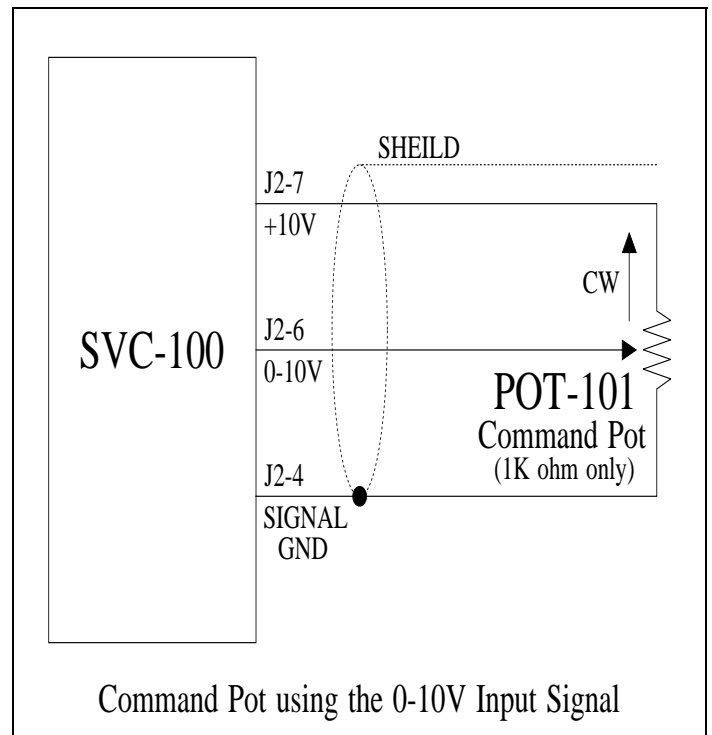
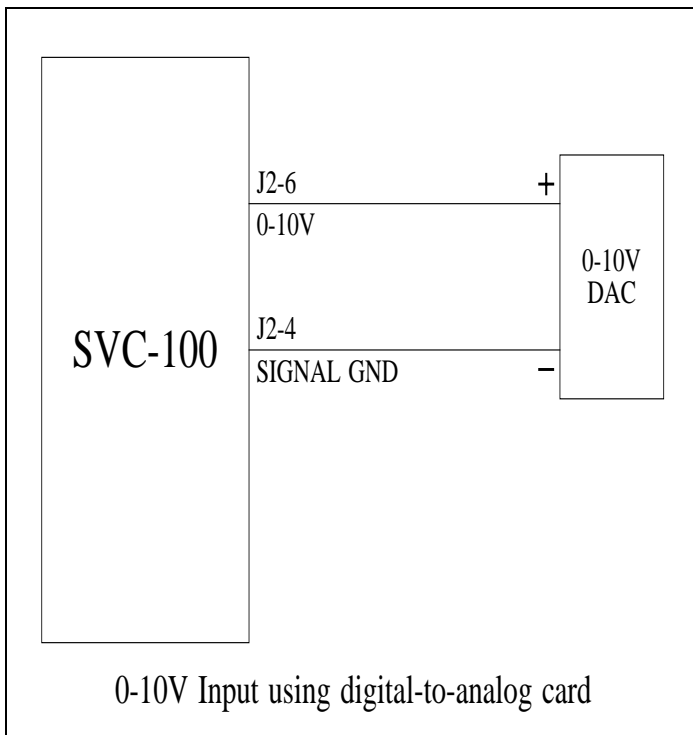
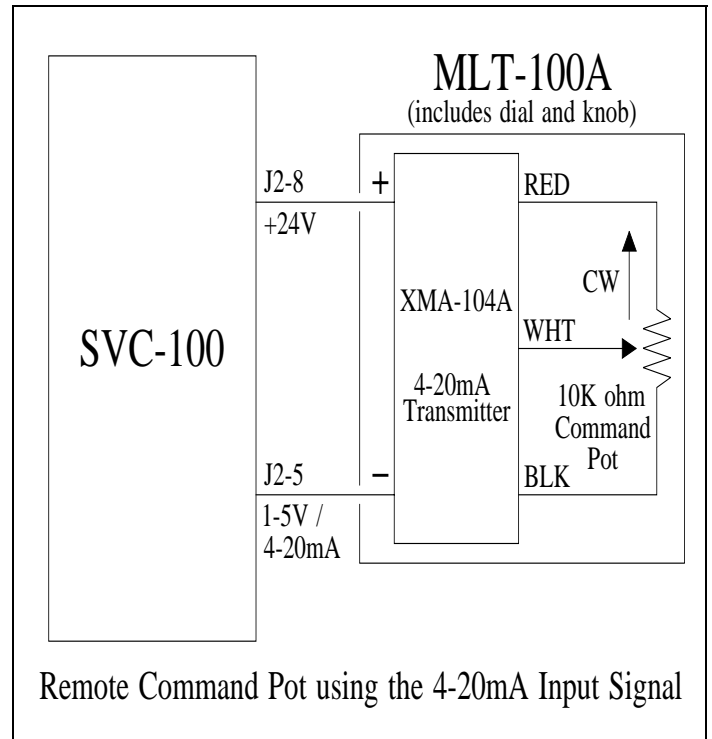
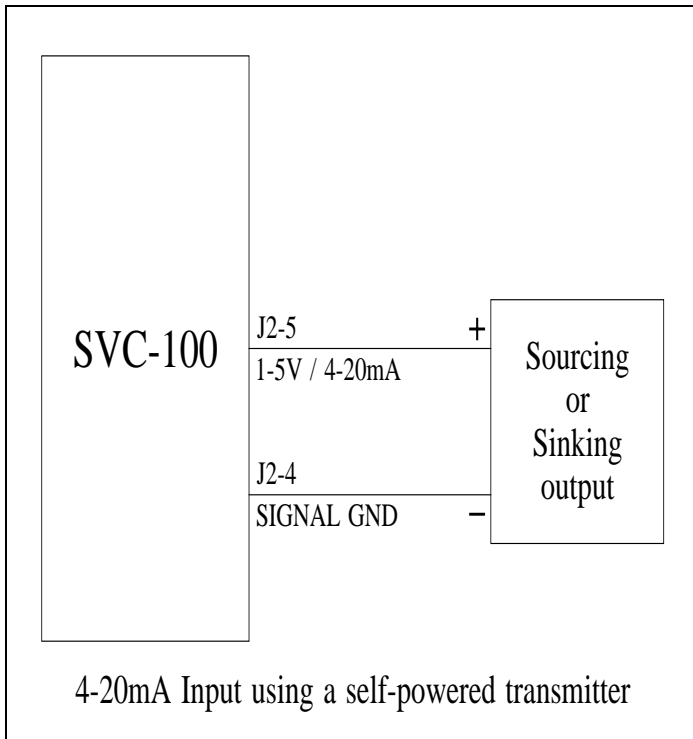

WIRING DIAGRAMS

Special Applications

