

LIMITORQUE

Limitorque Actuation Systems

FCD LMAIM1312-00
(Replaces 130-11010)

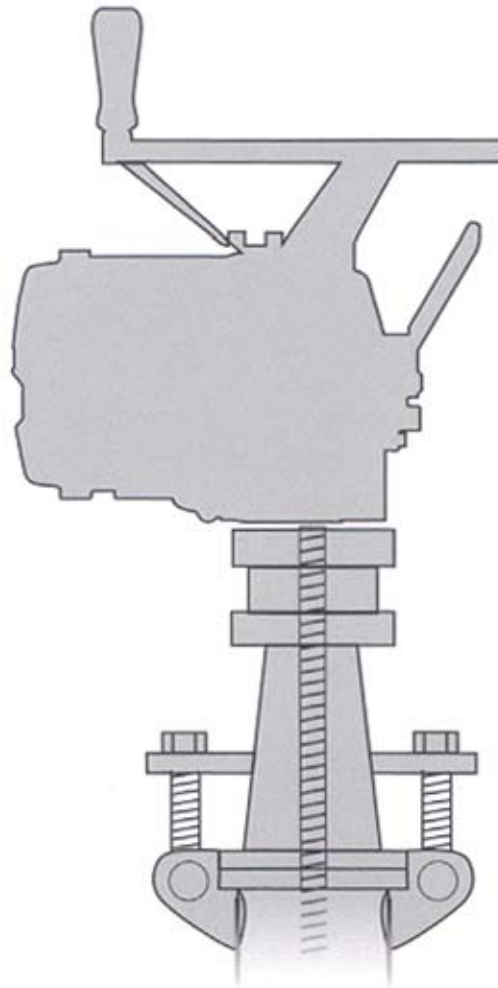

Limitorque[®]
Accutronix MX
Quick Mounting Instructions

The Limitorque Accutronix MX is the technological leader among electric actuators and the simplest device to install and commission. Follow this simple step-by-step installation guide to install the MX on all valve types. Refer to the following documents for more set-up information:

- **LMAIM1310, Quick Start-Up Instructions**
calibration of valve position limits
- **LMAIM1306, Installation and Operation Manual**
complete installation instructions

Contents

Preparing the Stem Nut	4
Type "B" Bases: Torque-only Applications	4
Standard B4/B4E Base	4
Optional B1 Base (not applicable for MX-85 or -140)	5
Type "A" Bases: Thrust-only Applications	6
Standard A1/A1E Base	6
Type "BL" Drive: Splined-drive Applications (not applicable for MX-85 or -140)	11
Mechanical Installation of MX Actuator onto Valve or Gearbox	11
Mounting (Type "B" Bases): Torque-only	12
Removal (Type "B" Bases): Torque-only	12
Mounting (Type "A" Bases): Thrust-only	12
Removal (Type "A" Bases): Thrust-only	13
Checking the Settings	13

Preparing the Stem Nut

The Accutronix MX has two (2) basic base designs:

- Torque-only base, designated by a "B" prefix
- Thrust-only base, designated by an "A" prefix

Type "B" Bases: Torque-only Applications

Standard B4/B4E Base

The standard MX actuator base is the B4 torque-only and includes a mounting plate and steel torque nut, which may be machined to fit a valve or gearbox.

A B4E torque nut can be provided and may be installed to allow for extended stem acceptance.

B4 base



B4E base



Exploded view of B4/B4E base

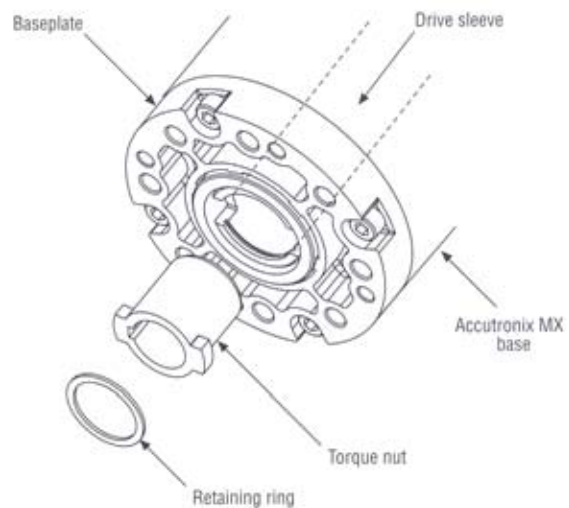

Disassembly

1. Remove the retaining ring (B4 base) or spiral-wound ring (B4E base) that retains the torque nut in the drive sleeve.
2. Remove the torque nut. If the torque nut is difficult to remove, insert a suitable device into the drive sleeve through bore and gently tap it loose from the handwheel end.
3. Machine the torque nut to suit the valve stem or gearbox input shaft (see **LMASS1326, MX Performance and Dimensions** for maximum stem capacity). Ensure sufficient clearance for a smooth, sliding fit.

Reassembly

1. Clean the torque nut thoroughly and lightly grease.
2. Replace the torque nut in the drive sleeve. Ensure the torque nut meshes with the drive lugs.
3. Refit the retaining ring (B4 base) or spiral-wound ring (B4E base).

Optional B1 Base (not applicable for MX-85 or -140)

An optional torque base assembly may be added to allow for a greater stem acceptance. This base is supplied with a fixed bore and key as defined by ISO 5210.

Disassembly

No disassembly is required since the torque nut has been machined to an international standard. Clean the bore and lightly grease.

B1 base

LIMITORQUE

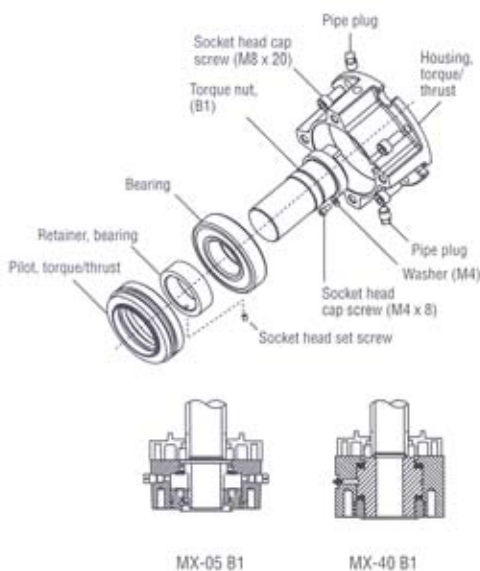
Exploded view of B1 base**Type "A" Bases: Thrust-only Applications****Standard A1/A1E Base**

The standard MX actuator thrust base is the A1 and may be bolted directly to the actuator. The thrust base contains a bronze alloy thrust nut that may be machined to suit the valve stem.

An A1E thrust nut can be provided and may be installed to reach shorter stems.

A1 base

LIMITORQUE

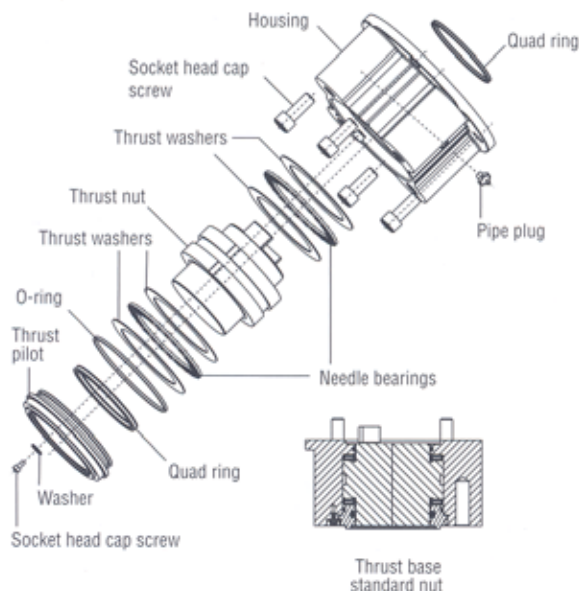
Exploded view of A1/A1E base (MX-05/10/20/40 only)**Disassembly – Units MX-05/10/20/40**

Refer to the figure at left.

Disassembly of the main housing from the base may be recommended to allow the base to remain on the valve if the actuator must be removed for service.

Pilot removal

MX-05/10: Remove the screw and washer holding the valve pilot to the thrust base and remove pilot.

MX-20/40: Turn counterclockwise (CCW) and remove.

Thrust bearing and nut removal

1. Remove the first set of thrust washers and bearing.
2. Remove stem nut.

NOTE: The thrust washers, bearing, and stem nut may be removed at the same time. The second set of thrust washers and bearing do not have to be removed.

3. Machine the stem nut to suit the valve stem. Ensure sufficient clearance to avoid unnecessary wear and heating during operation.

Reassembly – Units MX-05/10/20/40

Refer to the figure on page 7.

1. Clean the stem nut, washers, and bearings thoroughly.
2. Slide the second set of thrust washers and bearing in place if removed.

NOTE: Order of assembly for thrust washers and bearing must be as follows: washer, thrust bearing, washer.

Pilot installation

MX-05/10: Slide pilot into thrust base assembly and secure with washer and screw. Tighten fully.

MX-20/40: Place pilot into thrust base and turn clockwise (CW) until pilot is tight.

Disassembly – Unit MX-85

Refer to the figure on page 9.

Disassembly of the main housing from the base may be recommended to allow the base to remain on the valve if the actuator must be removed for service.

Thrust base mounting plate removal

Remove the six socket head cap screws holding the valve mounting plate to the thrust base housing and remove mounting plate.

Thrust bearing and nut removal

1. Remove the first set of thrust washers and bearing.
2. Remove stem nut.

NOTE: The thrust washers, bearing, and stem nut may be removed at the same time. The second set of thrust washers and bearing do not have to be removed.

3. Machine the stem nut to suit the valve stem. Ensure sufficient clearance to avoid unnecessary wear and heating during operation.

Exploded view of thrust base (MX-85 only)

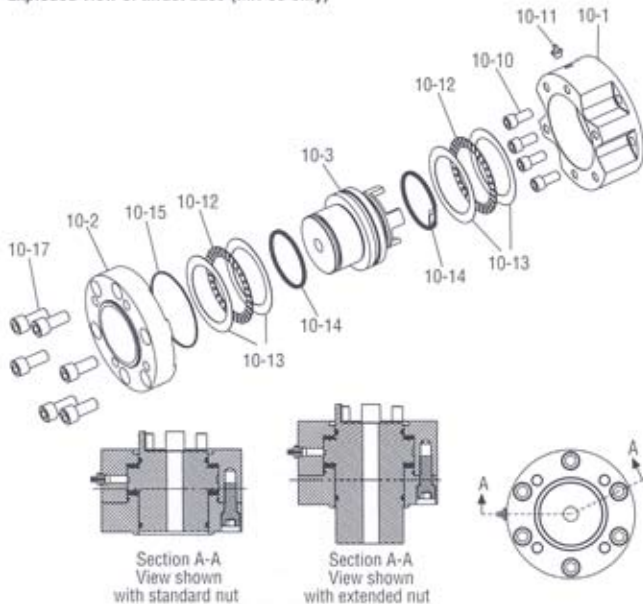

Reassembly – Unit MX-85

Refer to the figure at left.

1. Clean the stem nut, washers, and bearing(s) thoroughly.
2. Slide the second set of thrust washers and bearing in place if removed.
3. Install stem nut.
4. Install first set of thrust washers and bearing.

NOTE: Order of assembly for thrust washers and bearing must be as follows: washer, thrust bearing, washer.

Thrust baseplate installation

Mount baseplate to thrust base housing and install the six socket head cap screws to the proper torque per the table below.

Mechanical Installation of MX

Screw Size	Torque (ft-lb)
M8 or 5/16 inch	12-14
M10 or 3/8 inch	25-30
M12 or 1/2 inch	40-50
M16 or 5/8 inch	90-100
M20 or 3/4 inch	180-200

Exploded view of thrust base (MX-140 only)

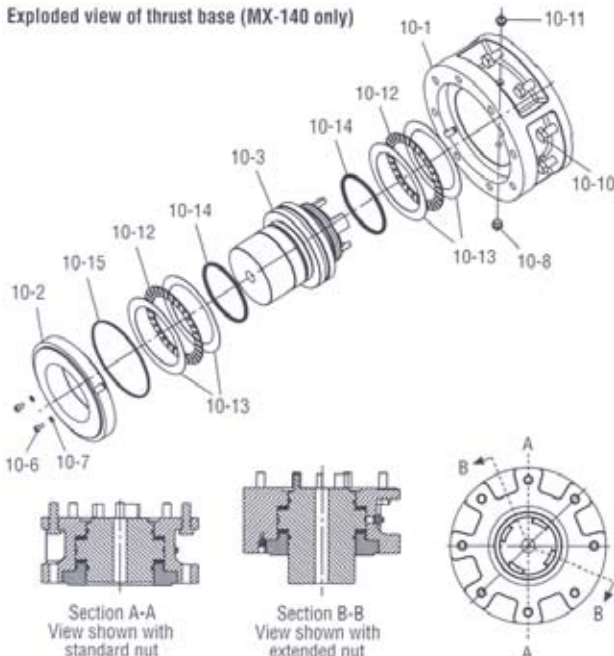

NOTE: Screw mounting torque for both mounting thrust base to main housing and thrust baseplate to thrust base housing.

Disassembly – Unit MX-140

Refer to the figure at left.

Disassembly of the main housing from the base may be recommended to allow the base to remain on the valve if the actuator must be removed for service.

Pilot removal

Remove the two screws and washers holding the valve pilot to the thrust base and remove pilot.

Thrust bearing and nut removal

1. Remove the first set of thrust washers and bearing.
2. Remove stem nut.

NOTE: The thrust washers, bearing, and stem nut may be removed at the same time. The second set of thrust washers and bearing do not have to be removed.

- Machine the stem nut to suit the valve stem. Ensure sufficient clearance to avoid unnecessary wear and heating during operation.

Reassembly – Unit MX-140

Refer to the figure on page 10.

- Clean the stem nut, washers, and bearing(s) thoroughly.
- Slide second set of thrust washers and bearing in place if removed.
- Install stem nut.
- Install first set of thrust washers and bearing.

NOTE: Order of assembly for thrust washers and bearing must be as follows: washer, thrust bearing, washer.

Pilot installation

Slide pilot into thrust base assembly and secure with the two washers and screws. Tighten fully.

Type “BL” Drive: Splined-drive Applications (Not applicable for MX-85 or -140)

Steel alloy splined nuts are provided to a standard involute spline

category for rising and rotating stem valves per customer requirements. Disassembly and reassembly is the same as the B4 base and the torque nut. See **Type “B” Bases: Torque-only Applications** section.

Mechanical Installation of MX Actuator onto Valve or Gearbox

NOTE: Refer to **LMAIM1314, MX Maintenance and Spare Parts** for more detailed instructions.

Before installing the actuator onto a valve or gearbox, check the following to ease installation:

- Verify mounting flange is suited dimensionally to mate with the actuator base. Ensure that it is perpendicular to the valve stem or gearbox input shaft.
- Ensure the stem nut mates with the valve stem or input shaft. For screwed nuts, it is advisable to run the stem nut down the entire length of the stem to check for tightness. Keyed or splined shafts should exhibit a smooth, sliding fit with the key installed.

- Ensure there is adequate engagement of the stem nut with the valve stem or input shaft when mounted. Generally, the minimum length of engagement is 1.5 times the diameter of the stem.
- Verify mounting studs or bolts are the correct length to suit the thickness of the mounting plate.
- Verify hardware specifications for English style: socket head cap screw per ASTM A 574 and ANSI 18.3. Hex head cap screw per SAE J429 Grade 5.
- Verify hardware specifications for metric style: hex and socket head cap screws per Property Class 12.9.
- Clean and lubricate the valve stem or input shaft.
- Ensure adequate lifting facilities and slings are available at the installation site.

NOTE: Do not use the handwheel to lift the actuator.

Mounting (Type “B” Bases): Torque-only

Refer to the figures on pages 4-6.

- Ensure the torque nut is secured inside the actuator drive sleeve with the retaining ring.

- Lower the actuator onto the valve or gearbox stem. Align the stem nut key and keyway with the valve or gearbox stem key seat.
- Verify that the actuator and valve mounting adapter flanges mate correctly.
- Secure the actuator to the valve mounting adapter with mounting bolts.

Removal (Type “B” Bases): Torque-only

Refer to the figures on pages 4-6.

- Remove the bolts that secure the actuator to the valve mounting adapter. If type B1 base is used in addition to the standard type B4 baseplate, you may leave the B1 base attached to the actuator and remove as a unit.
- Lift the actuator from the actuator mounting adapter.

Mounting (Type “A” Bases): Thrust-only

Refer to the figures on pages 6-8.

- The following are two options for mounting the type “A” base actuator:
 - If the type “A” thrust base was removed from the valve mounting adapter, replace the thrust base onto the valve mounting adapter.

Ensure the thrust base stem nut has the lugs positioned upward to engage with the drive sleeve slots when the actuator is reinstalled. Rotate the bronze nut while holding the base steady.

or

- If the thrust base is installed on the valve mounting adapter, proceed to step two.
- Lower the actuator along the threaded valve stem and onto the valve mounting plate. Ensure the thrust base stem nut lugs properly engage and align with the drive sleeve slots.
 - Install the bolts to secure the actuator to the thrust base assembly.

Removal (Type “A” Bases): Thrust-only

- Remove the bolts that secure the actuator to the thrust base assembly.
- Remove the type “A” thrust base by removing the bolts that secure the actuator to the valve mounting adapter.

or

 Leave the type “A” thrust base mounted to the valve mounting adapter until ready to remount the actuator. The thrust base will maintain valve position provided that the valve stem threads are locking.
- Lift the complete actuator from the thrust base.

Checking the Settings

When the assembly of the actuator to the valve is complete, the actuator position limits may be set. Please refer to **LMAIM1310, Quick Start-Up Instructions**, for calibration of valve/actuator position limits.

LIMITORQUE

Limitorque Actuation Systems



Flowserve Corporation has established industry leadership in the design and manufacture of its products. When properly selected, this Flowserve product is designed to perform its intended function safely during its useful life. However, the purchaser or user of Flowserve products should be aware that Flowserve products might be used in numerous applications under a wide variety of industrial service conditions. Although Flowserve can (and often does) provide general guidelines, it cannot provide specific data and warnings for all possible applications. The purchaser/user must therefore assume the ultimate responsibility for the proper sizing and selection, installation, operation, and maintenance of Flowserve products. The purchaser/user should read and understand the Installation and Maintenance (I & M) instructions included with the product, and train its employees and contractors in the safe use of Flowserve products in connection with the specific application.

Australian Distributor for Limitorque

Acrodyne Pty Ltd
14/11 Havelock Road
Bayswater Victoria 3153
Australia
p. 03 8727 7800
f. 03 9729 8699
e. info@acrodyne.com.au
www.acrodyne.com.au

While the information and specifications contained in this literature are believed to be accurate, they are supplied for informative purposes only and should not be considered certified or as a guarantee of satisfactory results by reliance thereon. Nothing contained herein is to be construed as a warranty or guarantee, express or implied, regarding any matter with respect to this product. Because Flowserve is continually improving and upgrading its product design, the specifications, dimensions and information contained herein are subject to change without notice. Should any question arise concerning these provisions, the purchaser/user should contact Flowserve Corporation at any one of its worldwide operations or offices.

For more information about Flowserve Corporation, visit www.flowserve.com or call USA 1 800 225 6989.

Limitorque Abex Road Newbury Berkshire, RG14 5EY England Phone 44-1-635-46999 Fax 44-1-635-36034	Limitorque Nippon Gear Co., Ltd. Asahi-Seimei Bldg. 4 th Floor 1-11-11 Kita-Saiwai, Nishi-Ku Yokohama-Shi, (220-0004) Japan Phone 81-45-326-2065 Fax 81-45-320-5962	Limitorque India, Ltd. 15/4, Mile Stone Mathura Road Faridabad 121002 India Phone 91-129-2276586 Fax 91-129-2277135	Flowserve Australia, Pty. Ltd. 14 Dalmore Drive Scoresby, Victoria 3179 Australia Phone 613-9729-2633 Fax 613-9729-2644	Limitorque Asia, Pte., Ltd. 12, Tuas Avenue 20 Singapore 638824 Phone 65-6868-4628 Fax 65-6862-4940
--	--	---	--	---