

Limitorque Actuation Systems

401-12000

Rev. B

Feb. 2003



Limitorque[®] Modutronic 20 II Installation & Maintenance Manual

Limitorque Actuation Systems

401-12000

Rev. B

Feb. 2003



Limitorque[®] Modutronic 20 II Installation & Maintenance Manual

Modutronic 20 II Installation & Maintenance Manual

©2003 Copyright Limitorque. All rights reserved.
Printed in the United States of America.

Disclaimer

No part of this book shall be reproduced, stored in a retrieval system, or transmitted by any means, electronic, mechanical, photocopying, recording, or otherwise without written permission from Limitorque. While every precaution has been taken in the preparation of the book, the publisher assumes no responsibility for errors or omissions. Neither is any liability assumed for damages resulting from the use of the information contained herein.

This document is the proprietary information of Limitorque furnished for customer use ONLY. No other uses are authorized without written permission from Limitorque.

Limitorque reserves the right to make changes, without notice, to this document and the products it describes. Limitorque shall not be liable for technical or editorial errors or omissions made herein; nor for incidental or consequential damages resulting from the furnishing, performance, or use of this document.

The choice of system components is the responsibility of the buyer, and how they are used cannot be the liability of Limitorque. However, Limitorque's sales team and application engineers are always available to assist you in making your decision.

This manual contains information that is correct to the best of Limitorque's knowledge. It is intended to be a guide and should not be considered as a sole source of technical instruction, replacing good technical judgment, since all possible situations cannot be anticipated. If there is any doubt as to the exact installation, configuration, and/or use, call Limitorque at (434) 528-4400. The latest revisions to this document are available online at <http://www.limitorque.com>

Table of Contents

1 Introduction	1-1
1.1 Safety Information	1-1
1.2 Product Identification	1-2
1.3 Product Description	1-2
1.4 Product Features	1-2
1.5 Product Specifications	1-3
2 Operation	2-1
3 Definitions	3-1
4 Initial Checkout & Setup	4-1
4.1 Verify Correct Motor Rotation (Phasing) & OPEN/CLOSE Pushbutton Operation	4-1
4.2 Verify Limit Switch & Torque Switch Settings	4-3
4.3 Adjusting the Actuator Feedback Potentiometer	4-3
4.4 Connecting the Modutronic 20 II to Customer Command Signal Leads	4-4
5 Modutronic 20 II Presets	5-1
6 Calibration Procedure	6-1
7 Troubleshooting	7-1
8 Wiring Diagram	8-1
9 Schematic	9-1

Figures

Figure 1.1 – Modutronic 20 II	1-2
Figure 2.1 – LY with a Modutronic 20 II & Associated Actuator Components	2-1
Figure 3.1 – Calibration Positions	3-1
Figure 4.1 – Standard Motor Rotation & Reverse Motor Rotation Wiring Diagrams for Dual Voltage, Capacitor Start, Induction Run, and Single-Phase Low-Voltage Motors	4-2
Figure 4.2 – Standard Motor Rotation & Reverse Motor Rotation Wiring Diagrams for Dual Voltage, Capacitor Start, Induction Run, and Single-Phase High-Voltage Motors	4-2
Figure 4.3 – Potentiometer Calibration Components Shown on a LY Position Indicator	4-3
Figure 6.1 – Calibration Adjustments for the Modutronic 20 II	6-1
Figure 6.2 – mA Calibrator Typically Connects to an Interconnect Board Terminal Strip or Terminal Strips Located in the Rear of a Panel-Mounted Modutronic 20 II	6-2
Figure 6.3 – Modutronic 20 II Board Component Locations	6-2
Figure 6.4 – FAIL TO Mode JP1 Jumper	6-5
Figure 8.1 – Modutronic 20 II Typical 3-Phase Wiring Diagram	8-2, 8-3
Figure 9.1 – Modutronic 20 II Schematic Diagram	9-2, 9-3

Tables

Table 4.1 – Modutronic 20 II Terminal Connections	4-4
Table 5.1 – ON/OFF Potentiometer Turns for Desired Operating Time	5-1
Table 6.1 – DIP Switch Setting Levels of Deadband Accuracy	6-3

1

Introduction

1.1 Safety Information

This Installation & Maintenance Manual was written for the user who is adding Modutronic 20 II capability to an existing actuator or who wants to adjust and/or troubleshoot a previously installed Modutronic 20 II Controller. These guidelines provide the information that is necessary to correctly install, set up, calibrate, and troubleshoot the Modutronic 20 II Controller.

Your safety and satisfaction are very important to Limitorque. Please follow all instructions carefully and pay special attention to safety.

The following methods will be used to emphasize text throughout this manual:

▲ WARNING: Refers to personal safety. This alerts the reader to potential danger or harm. Failure to follow the advice in warning notices could result in personal injury or death.

CAUTION: Directs attention to general precautions, which, if not followed, could result in personal injury and/or equipment damage.

NOTE: Highlights information critical to the understanding or use of these products.

Bold text highlights other important information that is critical to system components.

CAPITALIZED text stresses attention to the details of the procedure.

Underlined text emphasizes crucial words in sentences that could be misunderstood if the word is not recognized.

The purpose of these emphasized blocks of text is to alert the reader to possible hazards associated with the equipment and the precautions that can be taken to reduce the risk of personal injury and damage to the equipment.

Read and become familiar with the material in these guidelines before attempting installation, operation, or maintenance of the equipment. Failure to observe precautions could result in serious bodily injury, damage to the equipment, or operational difficulty.

▲ WARNING: Read this Installation & Maintenance Manual carefully and completely before attempting to install or operate the Modutronic 20 II. Be aware of electrical hazards when installing or performing maintenance on the Modutronic.

1.2 Product Identification

Figure 1.1 – Modutronic 20 II

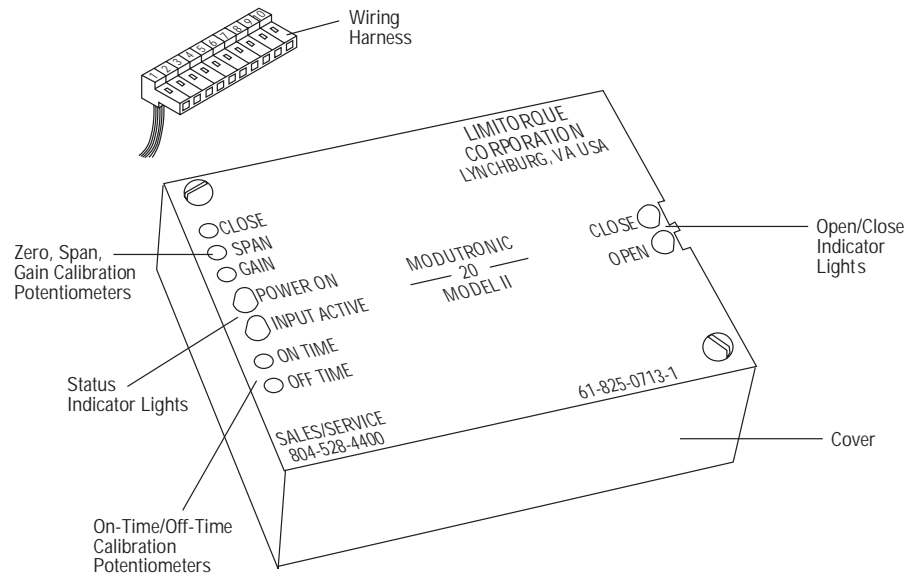

1.3 Product Description

The Modutronic 20 II™ is a solid state-integrated circuit-based controller. It is used to operate electric valve actuators in wastewater, petrochemical, and other industry applications requiring accurate modulation positioning. The standard input consists of a 4-20 mA signal generated by a process controller; the resulting output is used to accurately and repeatably position a valve actuator through conventional or solid state switching of either single or three-phase AC power.

1.4 Product Features

- Accuracy and repeatability of positioning within 1% of full-scale for actuator stroke times > 30 seconds.
- Solid state circuitry for longer life and reliable service.
- 4-20 mA command signal.
- Can be used to control single or three-phase systems.
- Jumper selectable **Lock-in-Last** or **Fail-Closed** configurations if command signal is lost.
- Five parameters available for adjustment allows actuator/application match.
- Adjustable ON and OFF motor control timers.
- LED indicators display signal, power, and control status to simplify calibration and monitor performance.

1.5 Product Specifications

Modutronic 20 II Specifications	
Power Requirements	Derived from actuator supply Board power 18 VAC or 24 VDC ($\pm 10\%$).3VA
Control Signal	4-20 mA
Accuracy	Within $\pm 1\%$ (>30 second stroke)
Loss of Command	Fail-to-last-position
Signal Selections	Fail-to-minimum-signal-position
Temperature	-40°C to +85°C (operating)
Maximum Starts Per Hour	Solid state reverser-600/hour Electromagnetic contactor-100/hour
Maximum direct output loading	Motor current-4.5 A Inrush, 3 A Holding
Dimensions	Mod 20-1.5"H x 3.25"W x 4"L Separate enclosure 11.7"H x 12.75"W x 17.4"L
Deadband	Adjustable between 1% and 10%
Resolution	1%
Linearity	1%
Humidity	To 95% (non-condensing)

This page is intentionally blank.

2 Operation

The Modutronic 20 II receives an input signal, normally 4-20 mA, from the external process controller. This signal is compared (within the Mod 20 II circuitry) to the present position of the actuator as indicated by the signal from the Feedback Potentiometer attached to the gear train of the actuator. The comparison of these two signals generates an error signal that dictates the direction and distance the actuator needs to be driven.

Upon generation of the error signal, the appropriate output triac is enabled and 115-volt control power is directed to the output contactor (this may be an electro-mechanical contactor or a solid state reverser depending upon the application).

As the actuator drives toward the set-point, it enters a region surrounding the set-point where the control function within the Mod 20 II changes from a continuous power application to a pulsing mode (proportional band). The Mod 20 II continuously compares the valve's actual position to the desired set-point through its circuitry; motor pulsing is continued until the actuator is accurately positioned at the set-point. The point in the valve travel at which the pulsing mode is enabled and spacing/duration of the pulses are all user adjustable on the Mod 20 II.

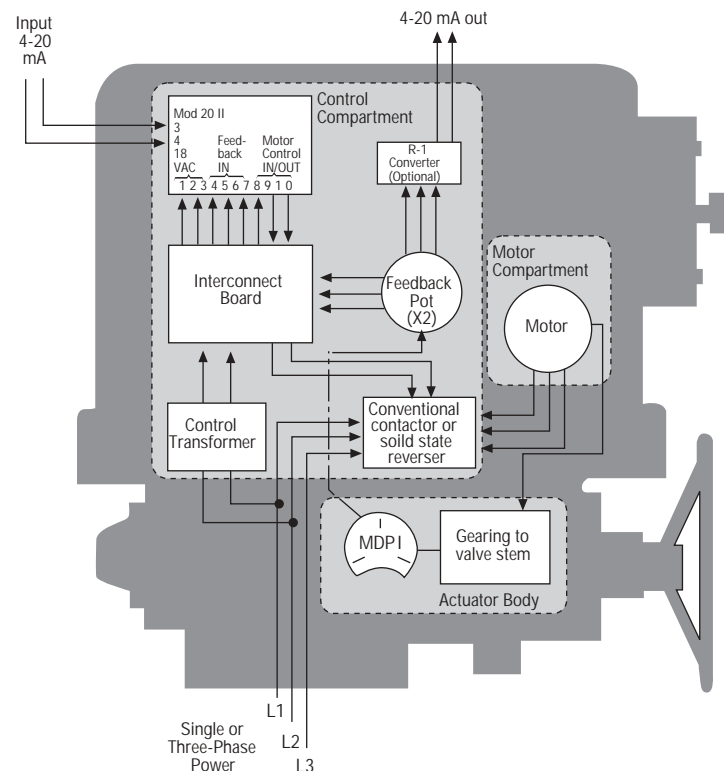

Figure 2.1 – LY with a Modutronic 20 II & Associated Actuator Components

This page is intentionally blank.

3

Definitions

Figure 3.1 – Calibration Positions

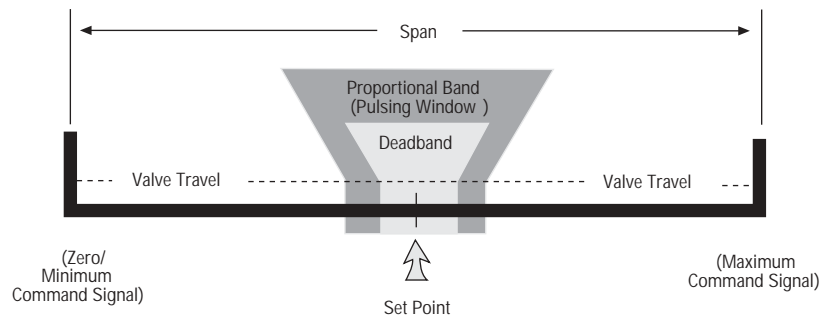

Command Signal Input signal provided by user to assign the desired valve position.

Deadband Adjusts the maximum allowable error signal. (Difference between the Position Command Signal and Position Feedback Potentiometer Signal). Selectable on the Mod 20 II DIP Switch. See **Table 6.1** for DIP Switch setting chart.

Proportional Band (Pulsing Window) controls the point on the scale of valve travel that the motor begins the pulsing mode. (Increasing GAIN decreases the window width).

- Adjusting the GAIN Potentiometer fully CW ↻ (increasing GAIN/decreasing pulsing window), sets the GAIN to its maximum setting causing the motor to run continuously up to the Set-Point before power is turned off from the motor.
- Adjusting the GAIN Potentiometer CCW ↻ (decreasing GAIN/increasing pulsing window), causes the Mod 20 II to begin to “pulse” the motor on and off as it approaches the Set-Point.

On Time Adjusts the time that the electro-mechanical contactors or Solid State Reversers are engaged while in the pulsing window.

Off Time Adjusts the time that the electro-mechanical contactors or Solid State Reversers or Solid State Reversers are disengaged while in the pulsing window.

Set-Point Desired stopping position for Mod 20 II; determined by the Command Signal.

Span Calibrates the Mod 20 II to align the Maximum Command Signal (normally 20 mA) with the Position Feedback Potentiometer at the open position.

Zero Calibrates the Mod 20 II to align the Minimum Command Signal (normally 4 mA) with the Position Feedback Potentiometer at the close position.

This page is intentionally blank.

4

Initial Checkout & Setup

4.1 Verify Correct Motor Rotation (Phasing) & OPEN/CLOSE Pushbutton Operation

It is very important to check for correct motor rotation to insure that serious damage to the valve or other equipment does not occur. If the actuator motor rotates in the wrong direction, over-torque damage could occur to the equipment.

Prior to being shipped from the factory, each actuator is inspected to verify proper operation of the Torque and Position Limit Switch and to ensure that they function correctly (i.e. closes when the CLOSE pushbutton is depressed, opens with the OPEN pushbutton, etc.). These inspections are made with a properly phased power source connected as described in the actuator manual.

CAUTION: To ensure proper operation and to prevent your actuator or other actuated equipment from damage, verify that your unit is properly connected to its power source.

NOTE: Your application may vary from the following standard wiring configurations for three-phase, single-phase, and DC motors. Refer to your actuator wiring diagram for user-specific wiring configuration.

Three-Phase Motor

1. Using the Handwheel, move the valve to a midtravel position (midtravel position allows electrical operation in the valve "safe" area and keeps the OPEN and CLOSED Limit Switches from tripping while testing motor direction).
2. Test motor direction by momentarily pressing the OPEN pushbutton:
 - a. If the actuator moves toward CLOSED, immediately turn all power OFF and reverse the motor leads T1 and T3.

NOTE: Refer to your actuator wiring diagram for user-specific wiring configuration.
 - b. If the actuator moves toward OPEN, the motor is wired properly for the application.

Single-Phase Motor

1. Using the Handwheel, move the valve to a midtravel position (midtravel position allows electrical operation in the valve "safe" area and keeps the OPEN and CLOSED limit switches from tripping while testing motor direction).
2. Test motor direction by momentarily pressing the OPEN pushbutton:
 - a. If the actuator moves toward CLOSED, immediately turn power OFF and proceed with the following instructions that match your application.
 1. **Permanent Split Capacitor** single phase motors can be connected for opposite rotation by interchanging the leads T1 and T2 coming from the motor to the terminal strip.

Limitorque Actuation Systems

2. **Single voltage, capacitor start, induction run, single phase motors** interchange leads T2 and T3 coming from the motor to the terminal strip.
3. **Dual voltage, capacitor start, induction run, single phase motors** can be connected for opposite rotation but the connection depends on whether the motor is operated on low voltage or operated on high voltage.
 - **Low voltage motors** are connected for opposite rotation as shown in the changes between the Standard Rotation configuration and the Reverse Rotation configuration in **Figure 4.1**. This is accomplished by interchanging the two leads T1 and T3 coming from the motor with the two leads T6 and T8 also coming from the motor. No other changes are necessary.

Figure 4.1 – Standard Motor Rotation & Reverse Motor Rotation Wiring Diagrams for Dual Voltage, Capacitor Start, Induction Run, and Single-Phase Low-Voltage Motors

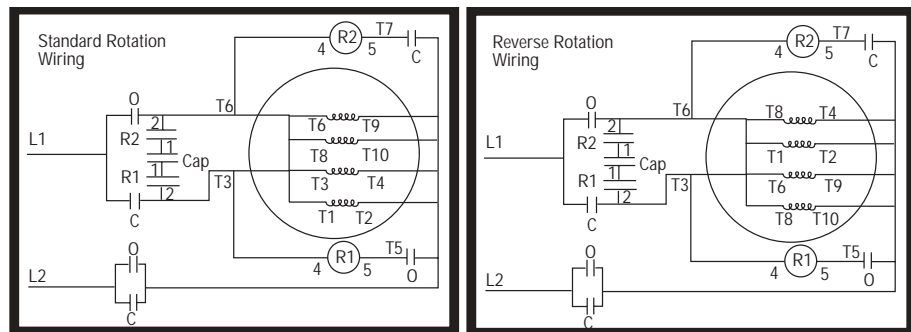

- **High voltage motors** are connected for opposite rotation as shown in the changes between the Standard Rotation configuration and the Reverse Rotation configuration in **Figure 4.2**. This is accomplished by interchanging two set of leads. First, interchange the leads T1 and T8 coming from the motor. Second, interchange leads T3 and T6 at the starting relays R1 and R2. No other changes are necessary.

Figure 4.2 – Standard Motor Rotation & Reverse Motor Rotation Wiring Diagrams for Dual Voltage, Capacitor Start, Induction Run, and Single-Phase High-Voltage Motors

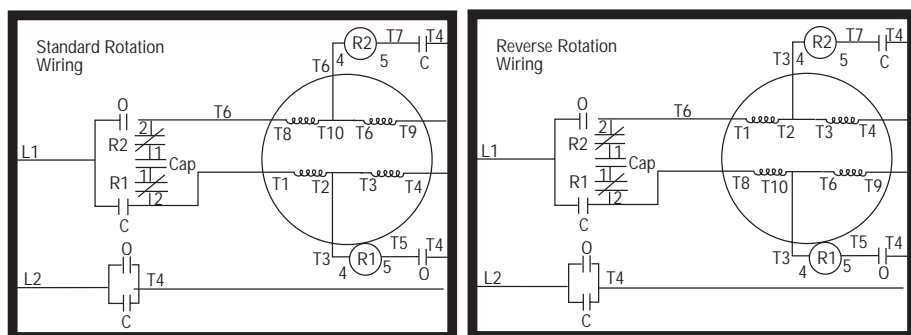

- b) Test Motor direction again by momentarily pressing the OPEN pushbutton. If the actuator moves toward OPEN, the motor is wired properly for the application. If not, check the wiring diagram for proper wiring.

4.2 Verify Limit Switch & Torque Switch Settings

Set the OPEN and CLOSE Limit Switch and the Torque Switch according to the instructions in the specific Actuator instruction manual.

4.3 Adjusting the Actuator Feedback Potentiometer

▲ WARNING: Hazardous Voltage. Turn power OFF before calibrating the Feedback Potentiometer.

1. Shut off all power to the actuator.
2. Using the Handwheel, position the actuator to mid-travel (valve at the 50% position).
3. Disconnect the Potentiometer Wiring Harness from where it is plugged in or connected to a Terminal Strip.
4. Using an Ohm Meter verify that the Potentiometer is in mid-travel position. The resistance from each End Connection to the Center Connection should be half of the full resistance of the Potentiometer. Example: 1000 ohm Potentiometer should read approximately 500 ohms from one of the End Connections to the Center Connection.

Figure 4.3 – Potentiometer Calibration Components Shown on a LY Position Indicator

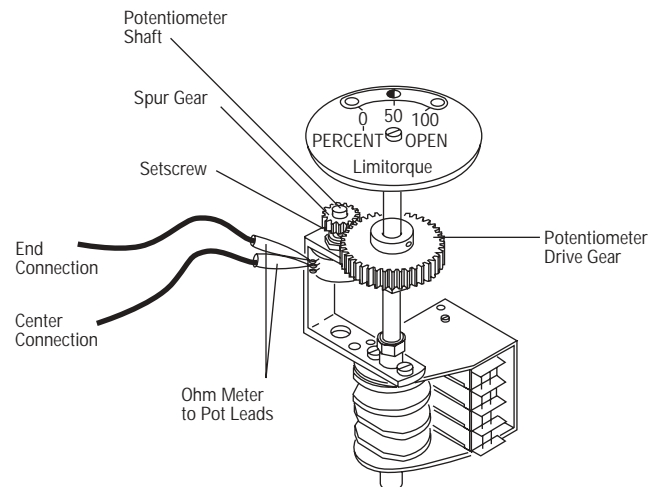

5. If the reading is not correct, proceed to **Step 6**. If the reading is correct proceed to **Step 7**.
6.
 - a. Loosen the small Set Screw that retains the Potentiometer Drive Spur Gear to the Potentiometer Shaft.
 - b. Remove the Spur Gear to allow manual rotation of the Potentiometer Shaft.
 - c. Rotate the Potentiometer Shaft until the correct readings are obtained as described in **Step 4**.
 - d. Reposition the Spur Gear to re-engage with the Gear Train.
 - e. Proceed to **Step 7**.
7. Disconnect the Ohm Meter and re-connect the Potentiometer wiring to original connection.

4.4 Connecting the Mod 20 II to Customer Command Signal Leads

▲ WARNING: Hazardous Voltage. Turn power OFF before removing the actuator cover and connecting the command signal.

If the Mod 20 II was factory installed, the only connection required is the user input command signal leads (normally 4-20mA). These connections should be made at the terminal strip in accordance with the wiring diagram enclosed with the actuator.

NOTE: If the unit does not have Limitorque supplied pushbuttons, refer to your wiring diagram to install a customer supplied pushbutton station.

If retrofitting or adding a Mod 20 II to an existing actuator, use the following connections table and your wiring diagram for wire lead designations.

Table 4.1 – Modutronic 20 II Terminal Connections



Mod 20 II		L120 Non-Compact	
Terminals	Description	Integral P.C. Board (61-825-0337-3)	
P1-1	18 Volt AC	18 Volt AC	} See Note
P1-2	18 Volt AC	Power Source	
P1-3	Negative 4-20 mA signal	TB1-5	} - 4-20 mA
P1-4	Positive 4-20 mA signal	TB1-4	
P1-5	Potentiometer	TB1-8	
P1-6	Potentiometer (wiper)	TB1-9	
P1-7	Potentiometer	TB1-10	
P1-8	115 Volt AC (output common)	TB2-5	
P1-9	Close Contactor Output	TB2-6	
P1-10	Open Contactor Output	TB2-7	

Note: To Terminal Strip or Control Power Transformer with 18-Volt tap.

5

Mod 20 II Presets

▲ WARNING: Hazardous Voltage. Turn power OFF before removing the actuator cover and connecting your command signal.

1. Shut off all power to the actuator to avoid equipment damage or personal injury.
2. Rotate the GAIN Potentiometer fully CCW , then 15 turns CW  to reach the midpoint of the Potentiometer. (See **Figure 6.3** for Potentiometer locations).

Note: Each 30-turn Potentiometer will faintly 'click' when rotated to either the maximum or minimum position.

















3. Rotate the ZERO Potentiometer fully CCW , then 15 turns CW  to reach the midpoint of the Potentiometer.
4. Rotate the SPAN Potentiometer fully CCW , then 15 turns CW  to reach the midpoint of the Potentiometer.
5. The following initial adjustments to the ON TIME and OFF TIME Potentiometers should be made to establish the proper pulsing sequence and duration for both electro-mechanical and solid state contactors.
 - a. Electro-mechanical contactor
 1. Rotate ON TIME and OFF TIME Potentiometers fully CCW , then 15 turns CW  to the midpoint of the Potentiometer.
 2. Rotate both the ON TIME and OFF TIME Potentiometers the number of times indicated in the **Table 5.1** to obtain the desired operating time.

Table 5.1 – ON/OFF Potentiometer Turns for Desired Operating Time

Operation	On Time	Off Time
<60 seconds	11 turns CW 	30 turns CW 
60-120 seconds	13 turns CW 	30 turns CW 
120 or > seconds	17 turns CW 	25 turns CW 

- b. Solid state reversers

1. Rotate ON TIME and OFF TIME Potentiometers fully CCW .
2. Rotate ON TIME Potentiometer 6 turns CW .
3. Rotate OFF TIME Potentiometer 8 turns CW .
4. This will provide a .04 second ON pulse and a .5 second OFF pulse.

NOTE: a. Rotating the ON TIME Potentiometer CW  will increase the ON time.
 b. Rotating the OFF TIME Potentiometer CW  will increase the OFF time.
 c. Adjusting one control (ON or OFF TIME Potentiometer) will affect the adjustment of the other control (ON or OFF Time Potentiometer).

NOTE: a. Electro-mechanical Starters should not exceed 100 total starts per hour.
 b. Solid State Reversers should not exceed 600 total starts per hour.

This page is intentionally blank.

6 Calibration Procedure

▲ WARNING: Hazardous Voltage in Control Compartment. Exercise caution while calibrating the Mod 20 II with the Actuator Control Compartment open and power ON.

The purpose of performing the calibration procedure is to achieve the maximum accuracy obtainable for each particular actuator application while providing stable operation. The actuator gear ratio and many other factors determine the optimum calibration settings.

Four DIP Switches mounted on the Mod 20 II, as well as the ZERO, SPAN, GAIN, ON TIME, and OFF TIME potentiometers, are used to obtain the proper settings for your application. This procedure will proceed from the most accurate settings to the least accurate settings until unit stability is achieved.

Figure 6.1 – Calibration Adjustments for the Modutronic 20 II

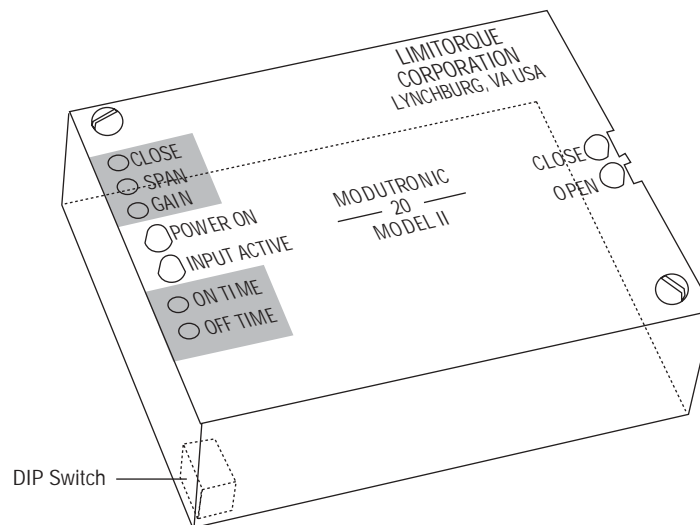

1. Turn all power to the actuator OFF.
2. Verify that the procedures for the Initial Checkout & Setup (pages 4-1 through 4-4) and Mod 20 II Presets (page 5-1) have been properly completed.
3. To simulate a command signal, connect the mA Calibrator to the Command Input Leads on the Mod 20 II. These terminations are typically connected to the actuator Interconnect Board or if the Mod 20 II is panel mounted, on the Rear Terminal Strip of the panel mount. In either case, these leads are labeled on your wiring diagram and will lead to connections 3 (P1-3[-]) and 4 (P1-4[+]) on the Mod 20 II.

Figure 6.2 – mA Calibrator Typically Connects (suggest Altek Model 334, www.altekcalibrators.com) to an Interconnect Board Terminal Strip or Terminal Strips Located in the Rear of a Panel-Mounted Mod 20 II

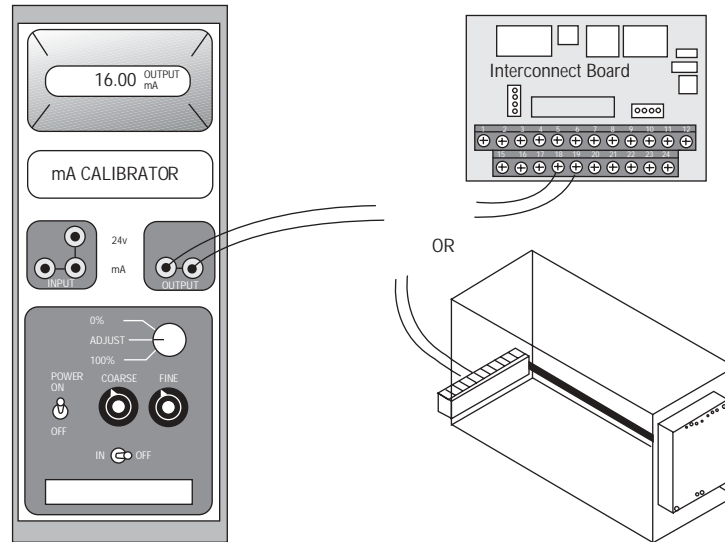

4. Set the Mod 20 II DIP Switch #3 to the ON position and DIP switch #s 1, 2, and 4 to the OFF position. This will set the error margin (DEADBAND) to 1% accuracy.

Figure 6.3 – Modutronic 20 II Board Component Locations

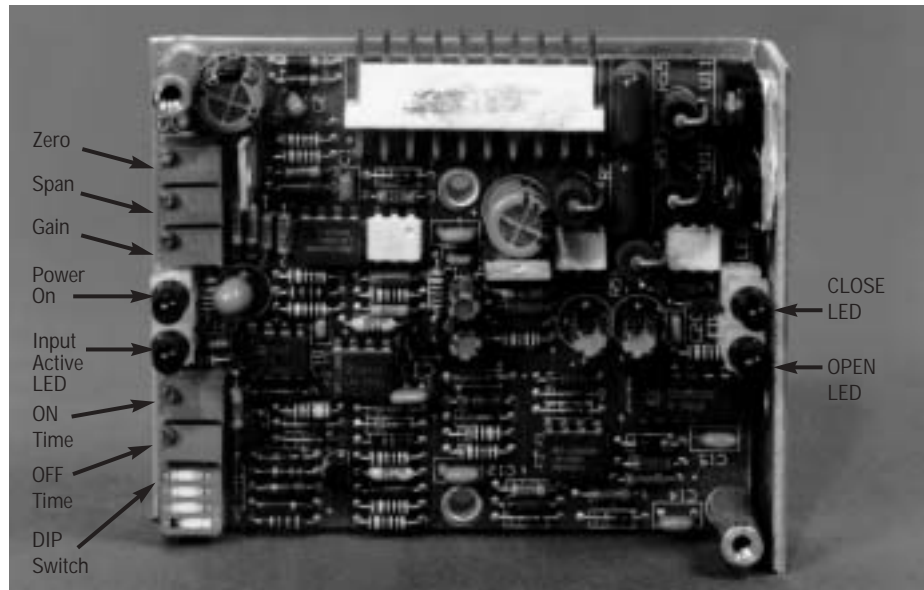





Table 6.1 – DIP Switch Setting Levels of Deadband Accuracy

Deadband Percentage	Dip Switch Number			
	1	2	3	4
± .5%	Off	Off	Off	On
± 1%	Off	Off	On	Off
± 1.5%	Off	Off	On	On
± 2.5%	Off	On	Off	Off
± 3.0%	Off	On	Off	On
± 3.5%	Off	On	On	Off
± 4.0%	Off	On	On	On
± 6.0%	On	Off	Off	Off
± 6.5%	On	Off	Off	On
± 7.0%	On	Off	On	Off
± 7.5%	On	Off	On	On
± 8.5%	On	On	Off	Off
± 9.0%	On	On	Off	Off
± 9.5%	On	On	On	Off
± 10.0%	On	On	On	On

▲ WARNING: Hazardous Voltage in Control Compartment. Exercise caution while calibrating the Mod 20 II with the Actuator Control Compartment open and power ON.

5. Set the mA Calibrator for the minimum signal level (normally 4 mA). The INPUT ACTIVE LED on the Mod 20 II should be illuminated. If not, reverse the polarity of the mA calibrator connections.
6. If the Actuator is equipped with an AUTO/MANUAL or LOCAL/REMOTE selector switch, turn the selector to the AUTO or REMOTE position.
7. Apply power to the Actuator and the Mod 20 II. The POWER ON LED on the Mod 20 II should be illuminated.
8. The Actuator may run in either direction and then stop;
 - a. If the unit stops, proceed to **Step 9**.
 - b. If the unit hunts back and forth, decrease the DEADBAND accuracy by changing the DIP Switch setting (refer to **Table 6.1**). Continue to **Step 9**.
 - c. If the unit runs all the way to one end of travel and stops, the Potentiometer Leads are probably wired backwards; reverse the Feedback Potentiometer's polarity by reversing the end leads at the Terminal Strip or on the Interconnect Board (if your application uses the Compact Integral Interconnect Board, the Plug-in Harness from the Pot to the Interconnect Board can be rotated 180° to reverse the polarity).
9. Adjust the ZERO point. This step calibrates the minimum or zero set-point to correspond to the end-of-travel of the Actuator and of the Feedback Potentiometer. Rotate the ZERO control slowly in the CW  direction. This will cause the Actuator to be driven slowly towards the minimum control position (normally CLOSED). Continue rotating the ZERO control CW  until the minimum (CLOSED) Position Limit Switch trips and the motor stops. The CLOSE LED should illuminate each time the Motor operates.

10. Adjust the control SPAN. This step calibrates the total SPAN of the control function and sets the maximum setting to correspond to the end-of-travel of the Actuator and of the Feedback Potentiometer.
 - a. Set the mA Calibrator to the maximum command signal (normally 20 mA).
 - b. The unit may:
 1. Run toward the maximum position and stop short of the Position Limit Switch trip point, or
 2. Remain in position.
 - c. Rotate the SPAN Potentiometer slowly CW . This will cause the Actuator to move slowly toward the maximum (normally OPEN) position. Continue rotating the SPAN control CW  until the maximum (OPEN) Position Limit Switch trips and the motor stops. The OPEN LED should illuminate each time the Motor operates.
11. After initially setting the ZERO and SPAN setting, use the mA Calibrator to set the Command Signal back to the minimum setting (usually 4 mA); allow the actuator to run until it stops. Now fine-tune the ZERO setting for the position where the Limit Switch just trips.
12. Use the mA Calibrator to set the Command Signal back to the maximum setting (usually 20 mA); allow the actuator to run until it stops. Now fine-tune the SPAN setting for the position where the Limit Switch just trips.

NOTE: If hunting continues during calibration procedure, it may be necessary to temporarily decrease the GAIN setting or increase the DEADBAND setting to get the ZERO and SPAN settings calibrated.

13. Adjust the ON TIME (optional). This step adjusts the period of time the Motor is energized in the pulsing mode when it is approaching the final set-point position.

NOTE: The ON TIME must be adjusted prior to adjusting the OFF TIME. Adjusting the ON TIME after adjusting the OFF TIME will require repeating the OFF TIME adjustment.

The duration of the ON TIME pulse to the Contactor/Solid State Reverser is increased by rotating the ON TIME Potentiometer CW .

14. Adjust the OFF TIME (optional). This step adjusts the period of time the Motor is de-energized in the pulsing mode when it is approaching the final set-point position. This can also be described as the interval between ON TIME pulses. The duration of the OFF TIME pulse to the Contactor/Solid State Reverser is increased by rotating the OFF TIME Potentiometer CW .
15. Adjust the GAIN. This step calibrates the width of the pulsing window around the set-point. This control works in conjunction with the four DIP Switches located on the Mod 20 II circuit board to determine the final accuracy of the unit in regard to set point position. The wider the pulsing window, the greater distance from the set-point the unit enters the pulsing mode. It is desirable to minimize the pulsing window without causing the Actuator to hunt (oscillate uncontrollably around the set-point).
 - a. For the initial calibration, ensure that DIP Switch 3 is ON and Dip Switches #s 1, 2, and 4 are OFF. This will provide 1% DEADBAND.

NOTE: If no DIP Switch is set to the ON position, the actuator will not operate.

 - b. Make sure the GAIN Pot is at the midpoint, then rotate the GAIN Potentiometer one turn CW .

- c. Start with the mA Calibrator at 4 mA, then make a 5 mA change in the output of the mA Calibrator to provide a significant change of position; now watch the action of the actuator.
 1. If the actuator hunts upon reaching the new set-point, reduce the GAIN control by turning in the CCW ↶ direction until the hunting stops and proceed to **Step e**.
 2. If the unit continues to hunt after the GAIN control adjustment, proceed to **Step d**.
 - d. Rotate the GAIN control fully CCW ↶ and then 15 turns CW ↷; adjust the DEADBAND to a less accurate setting and repeat the GAIN setting procedure starting with **Step a**. For example, if DIP Switch 3 is ON and DIP Switches 1, 2, and 4 are OFF the DEADBAND setting is at 1% accuracy; change the DIP Switch setting to 1-1/2% accuracy and repeat the procedures **13a** through **13e** until the correct DIP Switch and GAIN control eliminates actuator hunting. See **Table 6.1** for DIP Switch setting levels of deadband accuracy.
 - e. Rotate the GAIN control an extra 1/2 turn CCW ↶ to eliminate the possibility of future actuator hunting.
16. Set desired FAIL TO mode. See **Figure 6.4**.
- a. If LOCK-IN-LAST-POSITION is desired when loss of input signal occurs, install a jumper at JP1 to connect Pin 1 and 2.
 - b. If FAIL-TO-4mA-POSITION is desired when loss of input signal occurs, install a jumper at JP1 to connect Pin 2 and 3.

NOTE: Be sure to use one of the two jumper selections discussed above; FAIL-TO operation will be forfeited if JP1 is not used.

Figure 6.4 – FAIL TO Mode JP1 Jumper

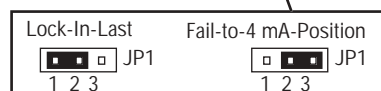
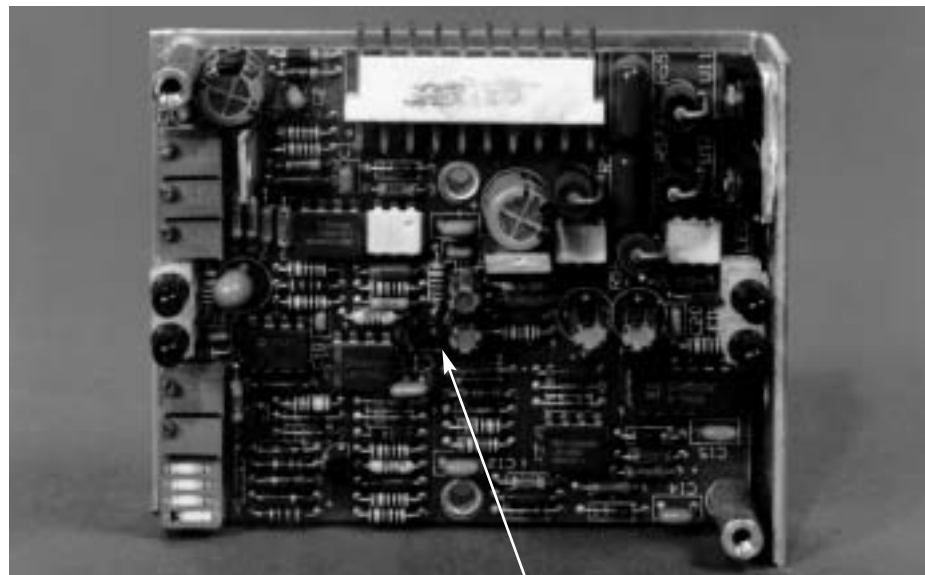

17. Your Mod 20 II should now be properly calibrated.

This page is intentionally blank.

7

Troubleshooting

Symptom	Possible Cause	Corrective Action
Unit will not operate electrically in AUTO or MANUAL	1. No power to unit	1a. Verify Power Supply is electrically correct and present at actuator. 1b. Verify Power Leads are connected in accordance with the applicable wiring diagram. 1c. Inspect for Blown Fuse, tripped Circuit Breaker, or OPEN Disconnect Switch.
	2. Wiring problems	2a. (LYs with internal Mod 20 II board) Check push-on terminal between the Integral PC Board and the Micro Switches. Check for bad Micro Switches on SW Station.
	3. Starter Wires loose	3a. Check all the connections on the Reversing Starter.
	4. Thermal overloads have tripped	4a. Measure continuity in the circuit. If you have an open circuit, wait for the motor to cool, then try to operate actuator. You may need to reduce the number of starts per hour.
Unit will not operate electrically in AUTO	1. No power to Mod 20 II	1a. Verify incoming 18 VAC between terminals P1-1 and P1-2 on Mod 20 II board.
	2. Bad Mod 20 II board	2a. Check board for burnt or broken components. Bypass Mod 20 II board using Pushbuttons to verify proper operation. See your specific wiring diagram for bypassing Mod 20 II board.
	3. Command Signal Leads reversed	3a. (L120 Interconnect PC Board) Check that the Command Signal Leads are wired to terminal TB16(+) and TB17(-).

continued on next page

(continued)

Symptom	Possible Cause	Corrective Action
Unit will not operate electrically in AUTO	4. Bad Potentiometer	4a. Check the Potentiometer with an ohm meter electrically in AUTO. Unplug the Pot from the Integral PC Board and take a meter reading between pins 7-1 and 7-2 or 7-2 and 7-3. The meter should have a steady reading. If the meter reading goes to zero or jumps around, verify that the Pot is centered. Replace the Pot if needed. Check for Cables that may have been pinched between the Housing Cover or Integral Assembly.
	5. All DIP switches turned Off	5a. Check DIP switches. Refer to Calibration Procedure on page 6-4, Step 15a.
Units run in one direction only	1. Shorted output	1a. Verify proper MANUAL direction operation. Using ammeter, verify proper command signal, verify all calibrations have been completed properly. If you still have difficulty calibrating the Mod 20 II after verifying the above settings, replace the Mod 20 II.
No LOCK-IN-LAST POSITION	1. Missing JP1 Jumper	1a. Locate JP1 Jumper on the Mod 20 II board and verify connections.
Unit will not follow signal	1. Bad Potentiometer or Potentiometer is not centered	1a. Check Pot as discussed in item #7. If Pot is OK, place the actuator at 50% and check the resistance between terminals 7-1 and 7-2 or 7-2 and 7-3 with an ohm meter. See "Adjusting the Actuator Feedback Potentiometer" procedure on page 4-3.
Input signal does not result in full travel of the valve	1. Mod 20 II not calibrated correctly	1a. See pages 6-1 through 6-5 result to review the calibration procedure for the Mod 20 II.
	2. ZERO and SPAN adjustments incorrect	2a. Recalibrate according to procedure on pages 6-1 through 6-5.

(continued)

Symptom	Possible Cause	Corrective Action
Large input signal variations result in little or no actuator movement	1. Improper analog Input Signal value	1a. Check for proper Input Signal value.
	2. Limit Switch	2a. Check for proper setting. (See appropriate actuator manual for setting the Limit Switches.)
	3. DEADBAND adjustment	3a. Check the DIP Switch accuracy adjustments shown in Table 6.1 .
	4. ZERO and SPAN adjustments	4a. Recalibrate according to procedure in Section 6 .

This page is intentionally blank.

8

Wiring Diagram

Please see page 8-2 for Modutronic 20 II Typical 3-Phase Wiring Diagram.

Figure 8.1 – Modutronic 20 II Typical 3-Phase Wiring Diagram

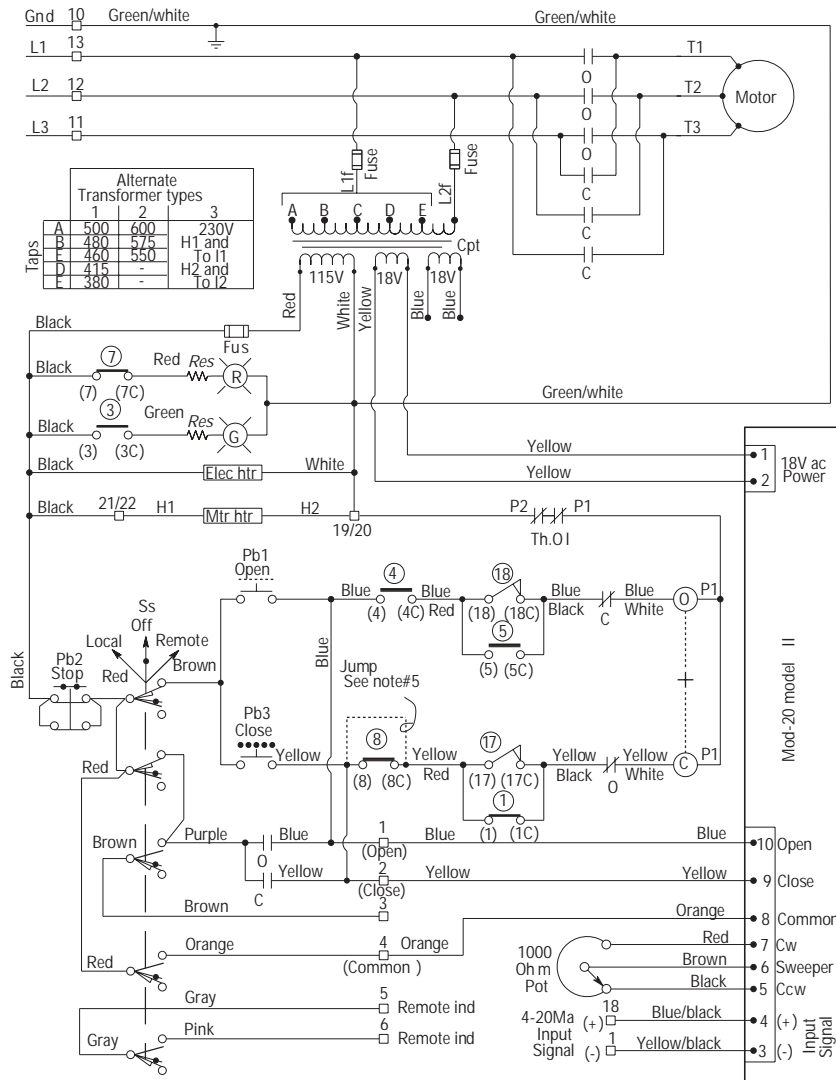

Valve shown in full open position

Rotor	Limit switch contact development	Valve position			Function
		Fully Open	A	B Fully Closed	
Open	1	Open	Open	Open	By-pass cir.
	2	Open	Open	Open	Spare
	3	Open	Open	Open	Ind light
	4	Open	Open	Open	Open limit
Close	5	Open	Open	Open	By-pass cir
	6	Open	Open	Open	Spare
	7	Open	Open	Open	Ind light
	8	Open	Open	Open	Close limit
Int.1	9	Open	Open	Open	Spare
	10	Open	Open	Open	Spare
	11	Open	Open	Open	Spare
	12	Open	Open	Open	Spare
Int.2	13	Open	Open	Open	Spare
	14	Open	Open	Open	Spare
	15	Open	Open	Open	Spare
	16	Open	Open	Open	Spare

- ⑰ Closing torque switch interrupts control circuit if Mechanical overload occurs during closing cycle
- ⑱ Opening torque switch interrupts control circuit if Mechanical overload occurs during opening cycle

NOTES

1. Open contact
2. ——— Close contact
3. See certification sheet for voltage supplied. Transformer unused wired to be separately Covered with insulating heat shrink tubing.
4. Rotors int.1 & Int.2 Can be set at valve Position full open, full closed or any Position in between as indicated by Points a and b.
5. Add jumper on Is#8 between terminals (8) & (8C) for torque seating valves

LEGEND

- O-open contact
- C-close contact
- ⊖ Opening coil
- ⊙ Closing coil
- Cpt-control power transformer
- + -Mechanical interlock
- Th.OI-thermal overload contacts
- ⊗ Red indicating
- ⊘ Green indicating
- Ss-selector switch (local-off-remote)
- Pb1-open pushbutton
- Pb2-stop pushbutton
- Pb3-close pushbutton
- Elec htr-compartment
- Mtr htr-motor heater
- Pot-potentiometer
- Res-lamp resistors

Figure 8.1 – Modutronic 20 II Typical 3-Phase Wiring Diagram (continued)

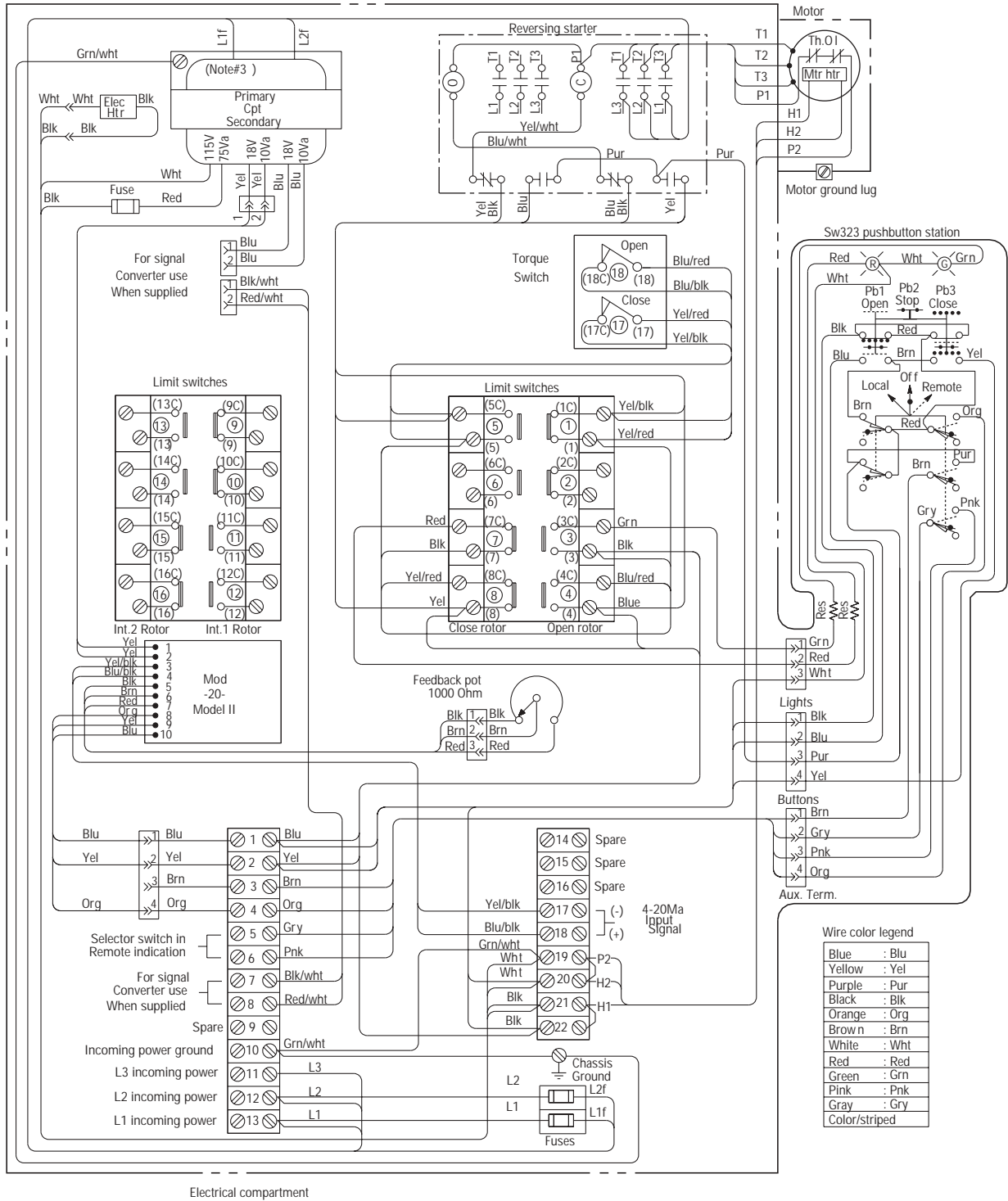

Drawing No. 17-500-0001-3

This page is intentionally blank.

9 Schematic

Please see page 9-2 for Modutronic 20 II Schematic Diagram.

Figure 9.1 – Modutronic 20 II Schematic Diagram

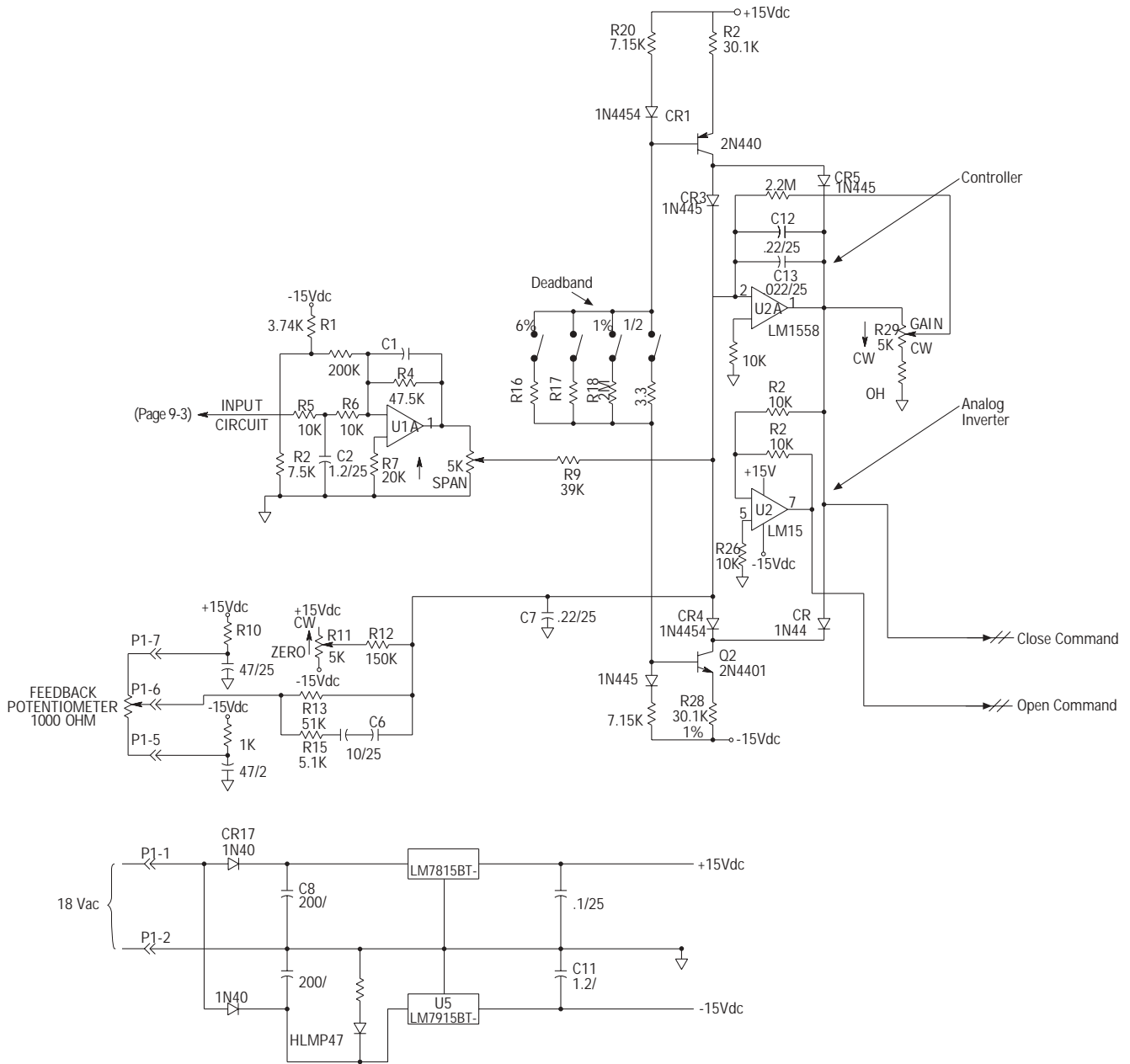

Input Impedance (Zin)

- Zin (4mA) = 850Ω
- Zin (8mA) = 550Ω
- Zin (12mA) = 450Ω
- Zin (16mA) = 400Ω
- Zin (20mA) = 370Ω

Figure 9.1 – Modutronic 20 II Schematic Diagram (continued)

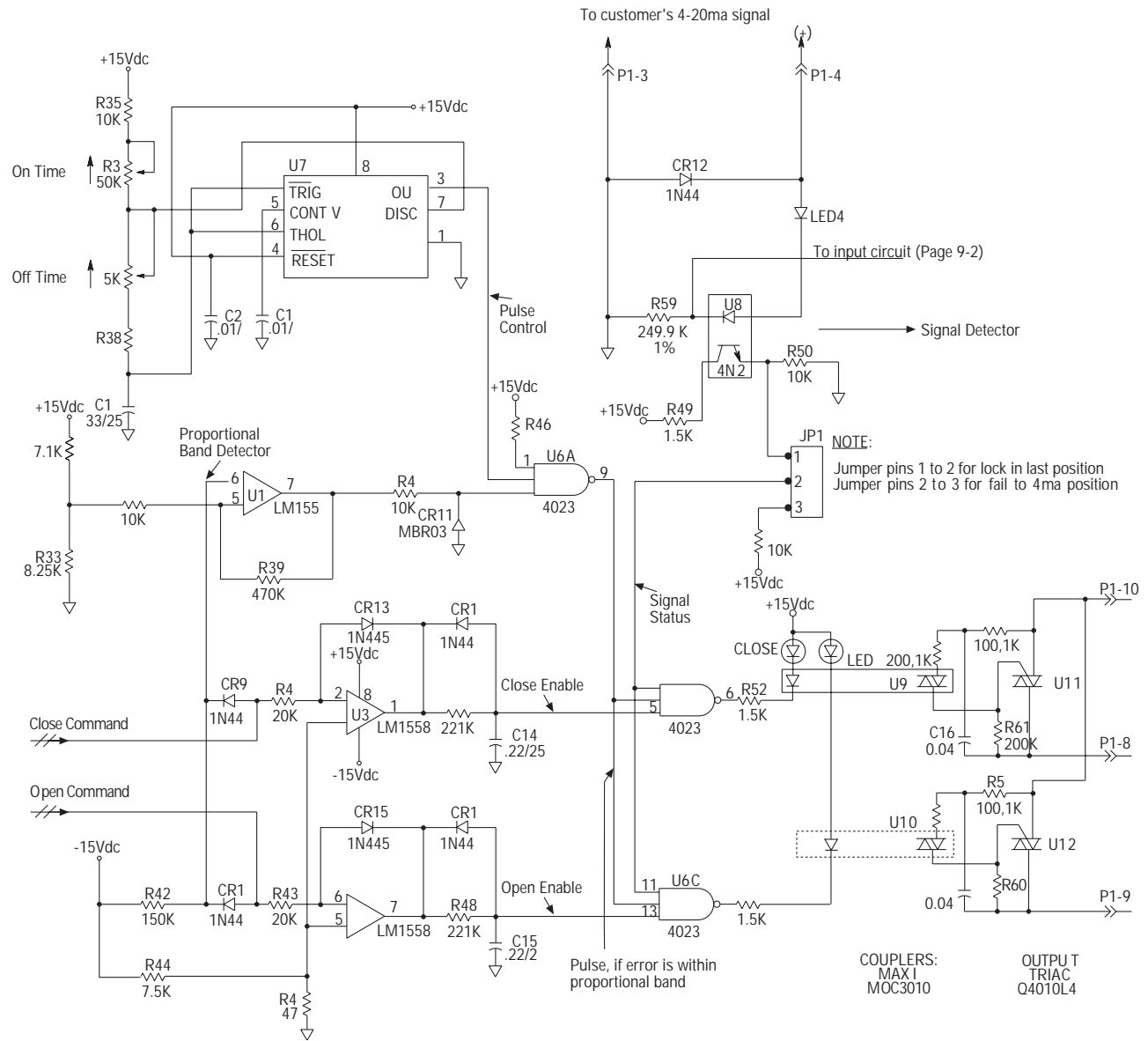

- Input Impedance (Zin)
- Zin (4mA) = 850Ω
 - Zin (8mA) = 550Ω
 - Zin (12mA) = 450Ω
 - Zin (16mA) = 400Ω
 - Zin (20mA) = 370Ω

Australian Distributor for Limitorque

Acrodyne Pty Ltd
14/11 Havelock Road
Bayswater, Victoria 3153
Australia
Phone 03-8727-7800
Fax 03-9729-8699