

Limitorque Actuation Systems

FCD LMAIM1203-00
(Replaces 120-12000)

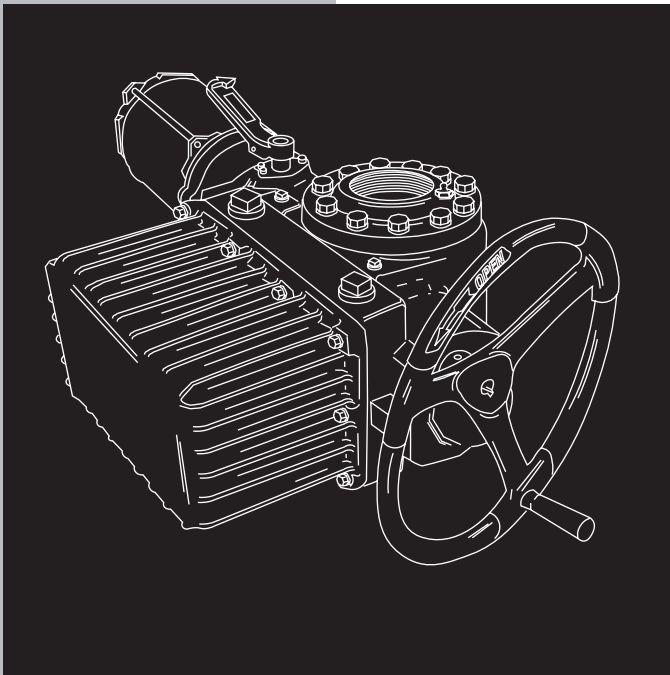

Limitorque®
L120-190 through L120-2000
Installation and Maintenance Manual

Limitorque Actuation Systems

FCD LMAIM1203-00
(Replaces 120-12000)

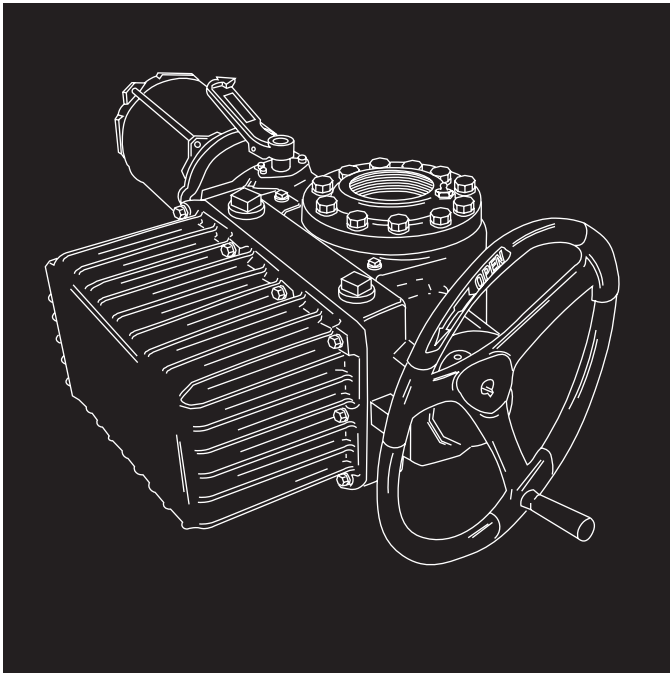

Limitorque[®]
L120-190 through L120-2000
Installation and Maintenance Manual

L120 Series Installation and Maintenance Manual

©2004 Copyright Limitorque. All rights reserved.

Printed in the United States of America.

Disclaimer

No part of this book shall be reproduced, stored in a retrieval system, or transmitted by any means, electronic, mechanical, photocopying, recording, or otherwise without the written permission of Limitorque. While every precaution has been taken in the preparation of this book, the publisher assumes no responsibility for errors or omissions. Neither is any liability assumed for damages resulting from the use of the information contained herein.

This document is the proprietary information of Limitorque, furnished for customer use ONLY. No other uses are authorized without written permission from Limitorque.

Limitorque reserves the right to make changes, without notice, to this document and the products it describes. Limitorque shall not be liable for technical or editorial errors or omissions made herein; nor for incidental or consequential damages resulting from the furnishing, performance, or use of this document.

The choice of system components is the responsibility of the buyer, and how they are used cannot be the liability of Limitorque. However, Limitorque's sales team and application engineers are always available to assist you in making your decision.

This manual contains information that is correct to the best of Limitorque's knowledge. It is intended to be a guide and should not be considered as a sole source of technical instruction, replacing good technical judgment, since all possible situations cannot be anticipated. If there is any doubt as to exact installation, configuration, and/or use, call Limitorque at (434) 528-4400. The latest revisions to this document are available online at <http://www.limitorque.com>

Table of Contents

1 Introduction	1-1
1.1 Purpose	1-1
1.2 User Safety	1-1
2 Product Capabilities and Features	2-1
3 Initial Inspection and Storage Instructions	3-1
3.1 Product Identification	3-1
3.2 Inspection and Recording	3-2
3.3 Storage Procedures	3-2
3.3.1 Short-Term Storage (less than 1 year)	3-3
4 Actuator Weights	4-1
5 Installation Instructions	5-1
5.1 Safety Precautions	5-1
5.2 Safety Practices	5-2
5.3 Prepare Initial Actuator	5-2
5.3.1 Mounting Base	5-2
5.3.2 Stem Acceptance	5-3
5.4 Double Torque Switch	5-3
5.4.1 Setting Torque Switch	5-4
5.4.2 Balancing Torque Switch	5-5
5.5 Geared Limit Switch - Rotor Type	5-5
5.5.1 Setting Limit Switch	5-6
5.5.2 Combination of Contacts	5-8
5.6 Position Indication	5-9
5.6.1 Local Position Indication	5-9
5.6.2 Remote Position Indication	5-10
5.6.3 Calibrating Position Transmitter PT20SD	5-10
6 Operation	6-1
6.1 Electrical Start-Up	6-1
6.1.1 Typical Wiring Diagrams	6-2
6.2 Manual Operation	6-2
6.3 Motor Operation	6-2
6.4 Torque and Travel Limiting	6-3
7 Maintenance	7-1
7.1 Lubrication	7-1
7.1.1 Lubrication Inspection	7-1
7.1.2 Factory Lubricant	7-2
7.1.3 Minimum Lubricant Qualities Required	7-2

7.2 Disassembly and Reassembly	7-2
7.2.1 Disassembling Actuator Sizes L120-190, -420 and -800	7-3
7.2.2 Reassembling Actuator Sizes L120-190, -420 and -800	7-4
7.2.2.1 To Replace Stem Nut Only	7-4
7.2.2.2 Gaskets	7-5
7.2.3 Disassembling Actuator Size 2000 Drive 1 and 2	7-5
7.2.3.1 Drive 2 (Thrust Actuator Only)	7-5
7.2.3.2 Drive 1 (Torque Actuator)	7-6
7.2.4 Reassembling Actuator Size 2000 Drive 1 (Torque Actuator)	7-7
7.2.5 Reassembling Actuator Size 2000 Drive 2 (Thrust Actuator Only)	7-9
8 Standard Wiring and Parts Diagrams	8-1
9 Troubleshooting	9-1
10 How to Order Parts	10-1
11 Regulatory Information	11-1

Figures

Figure 3.1 – L120-190 through 2000	3-2
Figure 5.1 – Double Torque Switch	5-3
Figure 5.2 – Setting Torque Switch	5-4
Figure 5.3 – Geared Limit Switch	5-6
Figure 5.4 – Setting Geared Limit Switch	5-7
Figure 5.5 – Position Indicators	5-9
Figure 5.6 – Typical Connection for a 1000 ohm Potentiometer	5-10
Figure 8.1 – Wiring Diagram – No Controls	8-1
Figure 8.2 – Wiring Diagram – Integral Controls	8-2
Figure 8.3 – Wiring Diagram – NCU	8-3
Figure 8.4 – Wiring Diagram – UEC-3	8-4
Figure 8.5 – L120-190 and -420	8-5
Figure 8.6 – L120-190 and -420	8-6
Figure 8.7 – L120-190	8-7
Figure 8.8 – L120-800	8-8
Figure 8.9 – L120-800	8-9
Figure 8.10 – L120-800	8-10
Figure 8.11 – L120-2000	8-12
Figure 8.12 – L120-2000 (Torque Base)	8-13

Tables

Table 4.1 – Actuator Weights	4-1
Table 5.1 – Mounting Base Dimensions	5-2
Table 5.2 – Maximum Stem Acceptance	5-3
Table 5.3 – Maximum Drive Sleeve Turns	5-6
Table 7.1 – Lubricant Weights	7-2
Table 8.1 – L120-190, -420 and -800 Typical Parts List	8-11
Table 8.2 – L120-2000 Typical Parts List	8-14

This page is intentionally blank.

1

Introduction

1.1 Purpose

This Installation and Maintenance Manual explains how to install and maintain L120-190 through -2000 actuators. Information on installation, disassembly, reassembly, lubrication, and parts is provided.

1.2 User Safety

Safety notices in this manual detail precautions the user must take to reduce the risk of personal injury and damage to the equipment. The user must read and be familiar with these instructions before attempting installation, operation, or maintenance. Failure to observe these precautions could result in serious bodily injury, damage to the equipment, warranty void, or operational difficulty.

Safety notices are presented in this manual in three forms:

▲ WARNING: Refers to personal safety. Alerts the user to potential danger. Failure to follow warning notices could result in personal injury or death.

CAUTION: Directs the user's attention to general precautions that, if not followed, could result in personal injury and/or equipment damage.

NOTE: Highlights information critical to the user's understanding of the actuator's installation and operation.

This page is intentionally blank.

2

Product Capabilities and Features

L120 Series actuators operate without modification in any rising or non-rising stem application for linear-action valves.

The actuators meet rigid safety requirements and are available in weatherproof, explosionproof, and submersible configurations.

The actuators are compatible with a wide range of control options from stand-alone actuators with local control stations to open standards-based DDC-100 networks with up to 250 actuators.

The actuators are designed with integral control packages including plug-in interconnect boards that increase control functionality for stand-alone or networked actuators.

Torque overload protection is provided in both directions of travel.

This page is intentionally blank.

3

Initial Inspection and Storage Instructions

▲ WARNING: Read this Installation and Maintenance Manual carefully and completely before attempting to store the actuator. Be aware of the electrical hazards.

3.1 Product Identification

The actuator nameplate is located on the back of the actuator opposite the limit switch controls compartment. The nameplate contains the following information:

- Limitorque name
- Point of manufacture
- Actuator size
- Order number
- Serial number
- Customer tagging
- CE stamp

The motor nameplate is located on the motor. The nameplate contains the following information:

- ID number
- Run torque
- RPM
- Full load amps
- Insulation class
- Space heater size
- Service Factor
- Cycles
- Ambient temperature
- Start torque
- Enclosure type
- Volts
- Locked rotor amps
- Duty
- Horsepower
- Phase
- Motor code
- Connection diagram

Figure 3.1 – L120-190 through 2000

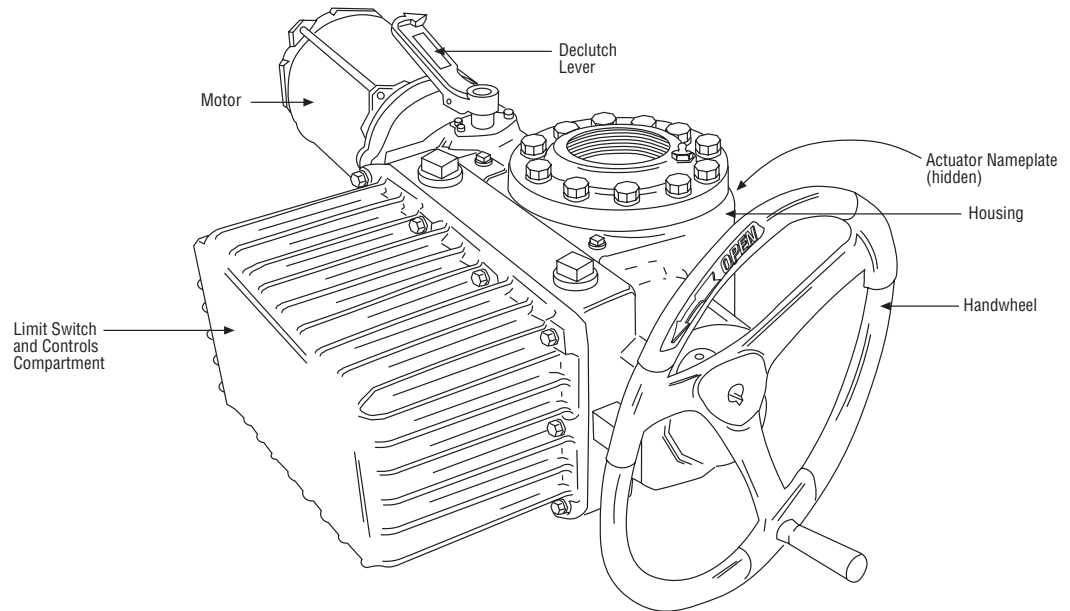

3.2 Inspection and Recording

Upon receipt of the actuator, inspect the condition of the equipment and record nameplate information.

1. Carefully remove actuator from shipping carton or skid. Thoroughly examine the equipment for any physical damage that may have occurred during shipment. If damaged, immediately report the damage to the transport company.
2. Record the actuator nameplate information for future reference, i.e., ordering parts, obtaining further information.

3.3 Storage Procedures

NOTE: The following are our recommended storage procedures to retain maximum product integrity during short-term storage. Failure to comply with recommended procedures will void the warranty. For longer-term storage, contact Limitorque for procedures and recommendations.

3.3.1 Short-Term Storage (less than 1 year)

Actuators are ***not weatherproof*** until properly installed on the valve or prepared for storage.

Store actuators in a clean, dry, protected warehouse away from excessive vibration and rapid temperature changes. If the actuators must be stored outside, they must be stored off the ground, high enough to prevent them from being immersed in water or buried by snow.

1. Position the actuator in storage with motor and switch compartment horizontal.
2. Connect the space heaters (if supplied) or place desiccant in the switch compartment.
3. Connect space heaters if actuator is to be stored in a damp place.
4. Replace all plastic caps or plugs with pipe plugs and ensure that all covers are tight.
5. If the actuator is mounted on a valve and the stem protrudes from the actuator, a suitable stem cover must be provided.

This page is intentionally blank.

4 Actuator Weights

The approximate L120 actuator weights are provided below:

Table 4.1 – Actuator Weights

Actuator Size	Control Types	Drive 1 Weight		Drive 2 Weight	
		Side HW		Side HW	
		lb.	kg	lb.	kg
L120-190	NCU ³	520	192	520	192
	BIC ³	586	217	586	217
	UEC/Clamshell ³	586	217	586	217
L120-420	NCU ³	1065	394	1065	394
	BIC ³	1130	418	1130	418
	UEC/Clamshell ³	1220	451	1220	451
L120-800	NCU ³	1270 ¹	471 ¹	1700 ²	629 ²
L120-2000	NCU ³	2500 ¹	925 ¹	3300 ²	1221 ²

Note 1: Torque Only

Note 2: Torque and Thrust

Note 3: NCU = No Controls Actuator

BIC = Basic Integral Controls

UEC = Universal Electronic Controller

This page is intentionally blank.

5

Installation Instructions

5.1 Safety Precautions

-
- ▲ **WARNING:** Read this Installation and Maintenance Manual carefully and completely before attempting to install, operate, or troubleshoot the Limitorque L120 actuator.
 - ▲ **WARNING:** Do not exceed any design limitations or make modifications to this equipment without first consulting Limitorque.
 - ▲ **WARNING:** Be aware of electrical hazards. Turn off incoming power before working on the actuator and before opening switch compartment.
 - ▲ **WARNING:** Actuators equipped with electrical devices (motors, controls) requiring field wiring must be wired and checked for proper operation by qualified tradesmen.
 - ▲ **WARNING:** Potential HIGH-PRESSURE vessel – Be aware of high-pressure hazards associated with the attached valve or other actuated device when installing or performing maintenance on your L120 actuator. Do not remove the actuator mounting bolts when the actuator is mounted on a rising stem valve unless the valve is in the FULLY OPEN position and there is NO pressure in the line.
 - ▲ **WARNING:** Do not manually operate the actuator with devices other than installed Handwheel and Declutch Lever. Using force beyond the ratings of the actuator and/or using additive force devices such as cheater bars, wheel wrenches, pipe wrenches or other devices on the actuator Handwheel or Declutch Lever may cause serious personal injury and/or damage to the actuator or valve.
 - ▲ **WARNING:** Do not torque-seat plug valves or butterfly valves without consulting valve manufacturer.
 - ▲ **WARNING:** Do not work on the actuator while it is mounted on a torque-seated valve. Do not attempt to remove either spring cartridge cap or housing cover while the valve is torque-seated. Always back the valve off the seat several handwheel turns before dismantling the actuator.
 - ▲ **WARNING:** Do not use oversize motor overload heaters—instead, look for the cause of overloading.
-

5.2 Safety Practices

The following check points should be performed to maintain safe operation of the L120 actuator:

- Mount motor on a horizontal plane, if possible. Preferably, keep the motor or limit switch compartment from hanging down. This prevents head of grease from being against motor or switch seals.
- Keep the switch compartment clean and dry.
- Keep the valve stem clean and lubricated.
- Set up periodic operating schedules for infrequently used valves.
- Verify that all actuator wiring is in accordance with the applicable wiring diagram.
- Carefully check for correct motor rotation direction. If the motor is driving the valve in the wrong direction, interchange any two leads on the three-phase motor or switch the armature leads on DC motors.
- Use a protective stem cover. Check valve stem travel and clearance before mounting covers on rising stem valves.
- Verify that a locking nut tightly secures the stem nut and that the top thread of the lock nut is crimped and staked in two places.
- For the DC motor, keep the armature clean and periodically check brushes for proper contact and wear.

5.3 Prepare Initial Actuator

Replace all molded plastic conduit and top protectors (installed for shipping purposes only) with pipe plugs when installation wiring is complete.

5.3.1 Mounting Base

The mounting hole sizes and quantities are as detailed in **Table 5.1**, below:

Table 5.1 – Mounting Base Dimensions

Actuator Size	Mounting Holes Quantity	Tap Size		Bolt Circle	
		MSS	ISO	MSS	ISO
L120-190	8	3/4–10 x 1.13	M20 x 2.5 x 32	11.75	298 mm
L120-420	8	7/8–9 x 1.75	N/A	14.0	N/A
L120-800 (Torque Only)	8	3/4–10 x 1.63	N/A	17.0	N/A
L120-800 (Thrust Only)	8	1.25–7 x 2.0	N/A	16	N/A
L120-2000 (Torque Only)	16	1–8 x 2.0	N/A	23.5	N/A
L120-2000 (Thrust Only)	12	1-1/2–6 x 3.0	N/A	18.0	N/A

5.3.2 Stem Acceptance

The maximum stem acceptance is provided in **Table 5.2**, below:

Table 5.2 – Maximum Stem Acceptance

Actuator size	Drive 2 Tapped		Drive 1 Bore		Drive 1 Key	
	inch	mm	inch	mm	inch	mm
L120-190	3.5	89	2.875	73	3/4 x 1/4	20 x 12
L120-420	5	127	4.25	108	1 x 3/4	28 x 16
L120-800	5	127	7	178	1 x 3/4	32 x 18
L120-2000	6.25	159	8.00	203	1-1/4 x 7/8	40 x 22

NOTE: For complete mounting dimensions, see sales brochure LMABR1200.

5.4 Double Torque Switch

The torque switch is designed to protect the actuator in open and close directions.

Figure 5.1 - Double Torque Switch

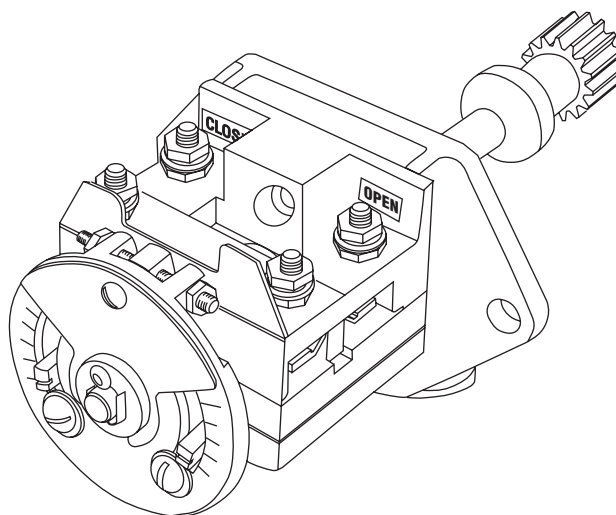

CAUTION: Disconnect all incoming power before opening limit switch compartment or working on the torque switch.

- Do not use abrasive cloth to clean the contacts on the torque switch.
- Do not torque-seat 90° operation valves or run them against the stops. This may cause damage to the valve.

NOTE: If the actuator has “torqued out,” release torque buildup by operating the actuator manually in opposite direction 1/2 to 1 turn of the output drive sleeve.

5.4.1 Setting Torque Switch

The torque switch was set at the factory according to customer-supplied information regarding necessary torque or thrust output provided at the time of the order. However, if the torque switch is newly installed or the setting needs to be adjusted, follow the procedure below:

CAUTION: A maximum stop setting plate is provided on most actuators. Do not remove this plate. Do not exceed the setting indicated by this plate without contacting Limitorque.

- Installing or adjusting the torque switch with the operator in a “loaded” condition will result in a loss of torque protection.

Item letters correspond to **Figure 5.2**.

1. Place the L120 actuator in manual mode.
2. Release the load on the wormshaft spring pack. Put operator in manual mode and operate in opposite direction until switch is in neutral position.
3. For open and close directions, loosen **Screw (A)** and move **Pointer (B)** to desired position. A higher number indicates a high torque and/or thrust output.
4. Tighten **Screw (A)**.
5. Operate the valve electrically to seat the valve and to ensure tight shutoff.

Figure 5.2 – Setting Torque Switch

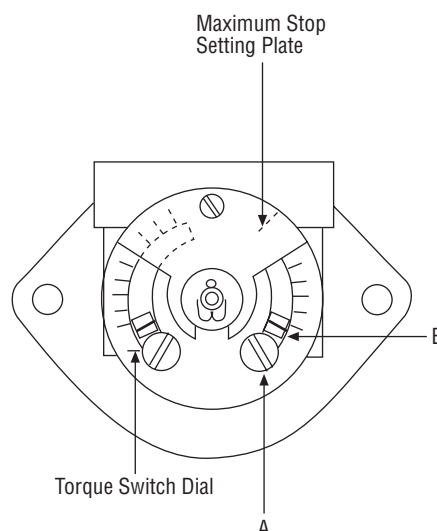

5.4.2 Balancing Torque Switch

Item letters correspond to **Figure 5.2**.

1. Place the actuator in manual mode.
2. Remove the load from the wormshaft spring pack.
NOTE: If the actuator has “torqued out,” release torque buildup by operating the actuator manually in opposite direction 1/2 to 1 turn.
3. Note the open and close torque switch settings prior to re-installing the torque switch.
4. Loosen **Screws (A)** and position both **Pointers (B)** at the #1 setting; tighten **Screws (A)**.
5. Mount the torque switch and tighten the mounting screws. Verify that both contact pointers are touching the arms. The interface between the pointers and the arm is found beneath the torque switch dial. If the pointers and the arms are not in contact, the clearance on the open and close torque switches should be equal. If not equal, the torque switch needs to be balanced. (See Step 7.)
6. If the pointers and arms are in contact on both sides of the switch, manually rotate the torque switch dial clockwise and counter-clockwise to determine if there is equal backlash in both directions of rotation. If there is not equal backlash in both directions, the torque switch needs to be balanced. (See Step 7.)
7. Loosen both hex nuts.
8. Back out one setscrew and tighten the other setscrew until there is equal backlash in both directions of rotation of the dial, or equal clearance between the pointers and arms.
9. Tighten the hex nuts and return the torque switch to its original settings.

CAUTION: The balancing screws should not be touched except during the balancing procedure.

The switch is now balanced and ready for the pointers to be returned to their original settings.

5.5 Geared Limit Switch – Rotor Type

CAUTION: The geared limit switch is not preset at the factory and must be adjusted after the actuator has been mounted on associated equipment.

- **Disconnect all incoming power to the actuator prior to opening the limit switch compartment and adjusting the switch.**
 - **Consult the relevant wiring diagram for limit switch contact development. All L120 actuators are supplied with 16-contact limit switches - four switches on each of the four rotors. Two rotors are used for end-of-travel indication. The remaining two rotors may be adjusted for any intermediate point-of-travel.**
 - **Do not use abrasive cloth to clean the contacts on the limit switch.**
 - **Do not attempt to repair gearing in the limit switch. Replace entire gear frame assembly if necessary.**
-

5.5.1 Setting Limit Switch

The maximum number of drive sleeve turns available is a function of actuator size, worm gear ratio, and type of switch. See **Table 5.3**. The **Intermediate Shaft** shown in **Figure 5.4** may take a considerable number of turns before rotor trip occurs.

▲ WARNING: Potential Explosion Hazard. Do not use a variable speed electric drill for setting the limit switch in an explosive environment.

CAUTION: When setting the limit switch rotor segments (cams) using a variable speed electric drill, do not run drill at speeds higher than 200 RPM. Operating the drill at high speeds can damage the gearing within the limit switch.

Table 5.3 – Maximum Drive Sleeve Turns

Actuator Size	W.G. Ratio	Limit Switch Gearing		PIC Gearing	
		4-Gear	5-Gear	PIC or R/I (270)	RVDT(90)
L120-190	13.3:1	3110	31100	13706	4569
	33:1	1250	12500	5521	1837
	60:1	690	6900	3037	1012
	85:1	N/A	N/A	N/A	N/A
L120-420	10.33:1	N/A	N/A	N/A	N/A
	16:1	3300	33000	11405	3797
	41:1	1280	12800	4445	1481
	57:1	910	9100	3195	1065
	80:1	N/A	N/A	N/A	N/A
L120-800	12.67:1	N/A	N/A	N/A	N/A
	19:1	2850	28500	9586	3195
	49:1	1050	10500	3720	1240
	58:1	N/A	N/A	N/A	N/A
	86:1	N/A	N/A <td N/A	N/A	
L120-2000	43:1	1210	12100	4234	1413
	71:1	740	7400	2566	855

Figure 5.3 – Geared Limit Switch

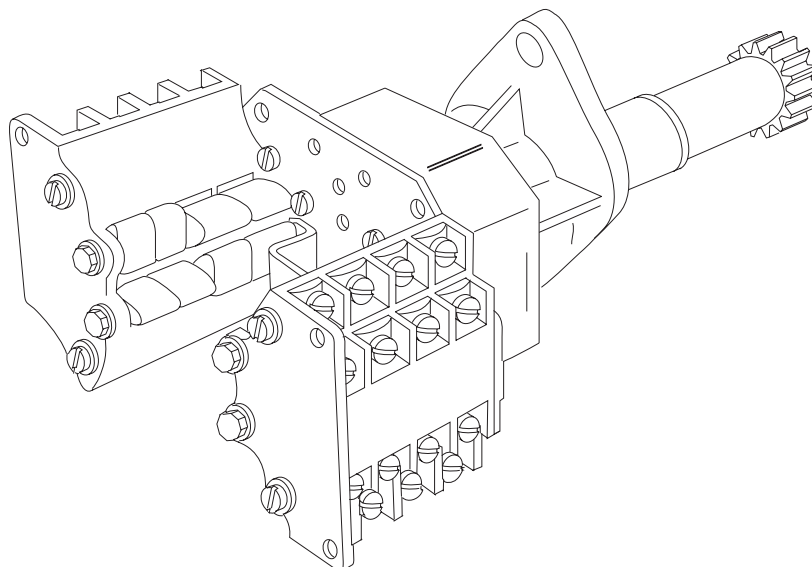

Set the limit switch as follows. All item letters and piece numbers refer to **Figure 5.4**.

Figure 5.4 - Setting Geared Limit Switch

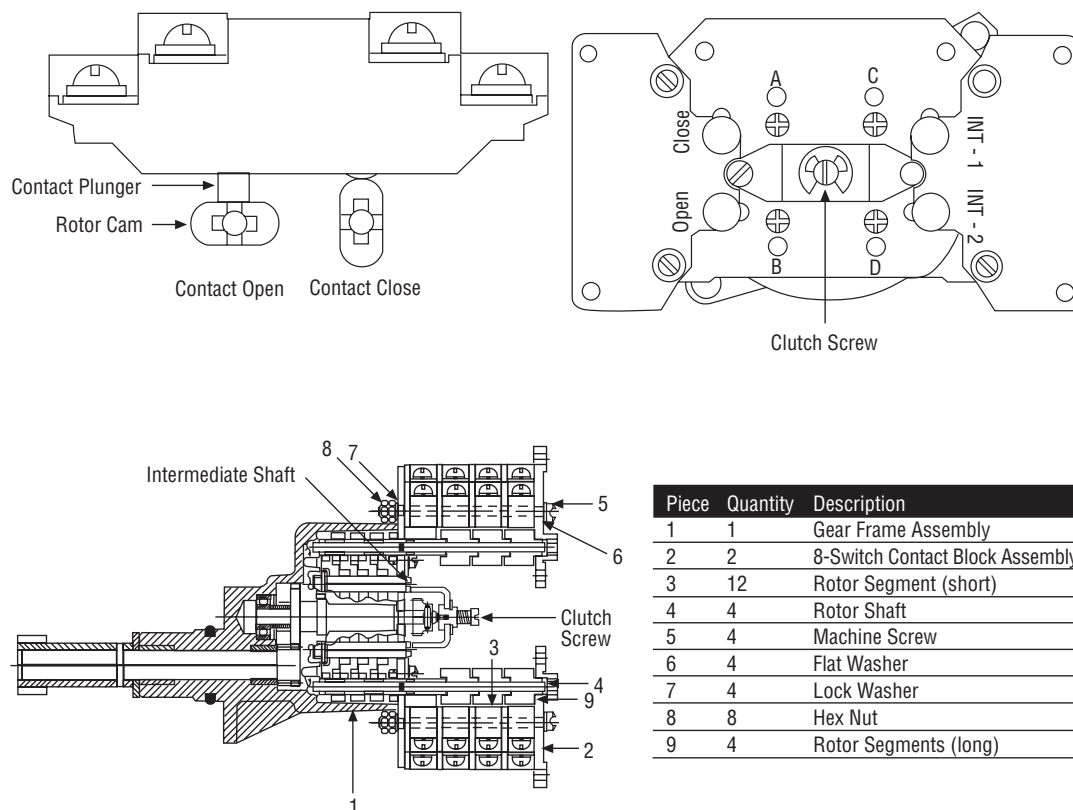

Unless otherwise noted refer to **Figure 5.4**.

1. Open the **Limit Switch Compartment Cover** (piece #200-1 of **Figure 8.7** for L120-190 and -420, **Figure 8.10** for L120-800, and **Figure 8.11** for L120-2000).
2. Put the actuator into manual operation. Use the handwheel to operate the valve in the “open” direction. While operating the valve, note the direction of rotation of the **Intermediate Shaft** corresponding to the rotor or rotors to be set.
3. When the valve is fully open, close it one turn of the handwheel to allow for coast of moving parts.
4. Push in the **Clutch Screw** and turn one-quarter turn. The rod will latch in this depressed position.
5. Refer to the applicable wiring diagram for contact development. The limit switch contact is closed when the rotor is engaged with the plunger. If the rotor to be set has not turned 90° to operate the plunger, turn the intermediate shaft in the same direction as noted in Step No. 2 until the rotor clearly trips the switches. This rotor is now set correctly.
6. If the intermediate position rotors 1 and 2 are also to be set at any desired position, repeat the setting operation in steps 1 through 5 above.
7. Before moving the valve, depress and turn the **Clutch Screw** counterclockwise one-quarter turn to the spring-released position. Insert a screwdriver into the intermediate shafts to ensure that they are loaded in position and will not rotate.

NOTE: The cross-slotted shafts A, B, C, and D have been designed for use with a No. 2 Phillips screwdriver shank chucked into a variable speed reversible electrical drill. Do not run drill at speeds higher than 200 RPM (see previous page CAUTION).

CAUTION: Do not operate the valve when the Clutch Screw is in a fully depressed position. Loss of contact setting will occur and the setting rod will be damaged.

8. Operate the valve by handwheel to the fully “close” position; reverse direction by one turn of the handwheel to allow for coast of moving parts.
9. Set the other rotors by following steps 1 through 7.
10. Secure the **Limit Switch Compartment Cover** (piece #200-1 of **Figure 8.7** for L120-190 and -420, **Figure 8.10** for L120-800, and **Figure 8.11** for L120-2000).

NOTE: For actuators having captive bolts, pull-down torque must not exceed 30 ft lbs.

5.5.2 Combination of Contacts

Refer to **Figure 5.4**.

The rotor segments can be separated and rotated through 90° to give various combinations of normally open or normally closed contacts to each rotor.

1. Remove **Nuts** (piece #8) and **Fillister Head Machine Screws** (piece #5) for a total of two fasteners on each side of the switch.
2. Remove complete contact assembly from the back plate.
3. Rearrange cams on the camshaft to produce the required combination of contacts.
4. Replace contact assembly on back-plate (ensuring the registers fit correctly) and secure with the machine screws and nuts.

5.6 Position Indication

5.6.1 Local Position Indication

The local dial position indicator is factory-built per the application. The position indicator can only be adjusted when mounted on the valve.

Figure 5.5 - Position Indicators

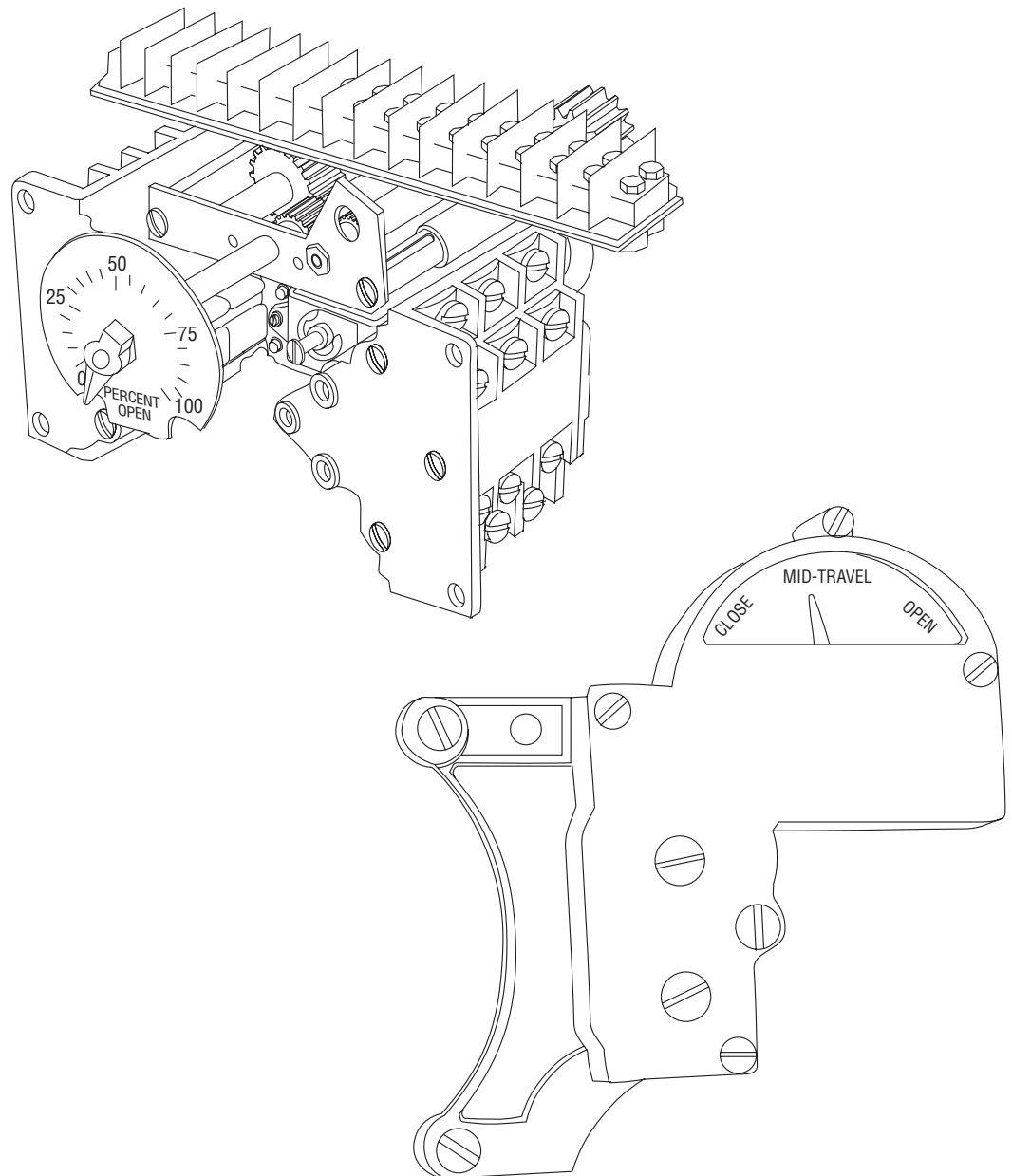

To set the local position indicator:

1. Disconnect all incoming power and remove **Limit Switch Compartment Cover** (piece #200-1 of **Figure 8.9** for L120-190, -420 and -800, and **Figure 8.11** for L120-2000).
2. Place the valve in the fully “close” position.
3. Loosen the round head machine screw which holds the pointer in place; move the pointer to the “0” position, and re-tighten the screw.

The indicator is now set.

NOTE: The end-of-travel rotors of the geared limit switch activate “flip-flop” type indicators. This type of indicator will require no further setting after the geared limit switch has been adjusted.

5.6.2 Remote Position Indication

The remote position indicator is a Limitorque digital position indicator. This indicator is a digital LED display module that displays valve position in 1% increments. The readout accepts inputs from signals of 4-20 mA, 0-2 V, or a 1000 ohm feedback potentiometer (mounted on the MDPI). The readout is accurate to 1% +/- 1 digit.

5.6.3 Calibrating Position Transmitter PT20SD

1. Position the actuator to mid-travel value at 50% position.
2. Disconnect the potentiometer wiring harness from the PT20SD board and measure the resistance from each end connection to the center connection on the potentiometer.
3. Set the potentiometer to the correct resistance reading. Loosen the setscrew that retains the spur gear on the potentiometer shaft and rotate the shaft until a reading of 500 ohms is achieved.
4. Tighten the setscrew and reconnect the wiring harness to the PT20SD.
5. Run the actuator fully CLOSED.
6. Calibrate ZERO position by adjusting the zero potentiometer until a 4mA output signal is read at terminal +Ve and -Ve.
7. Run the actuator fully OPEN.
8. Calibrate SPAN position by adjusting the span potentiometer until a 20mA output signal is read at terminals +Ve and -Ve.
9. Repeat steps 5 through 8 and fine-tune as necessary.

Figure 5.6 – Typical Connection for a 1000 ohm Potentiometer

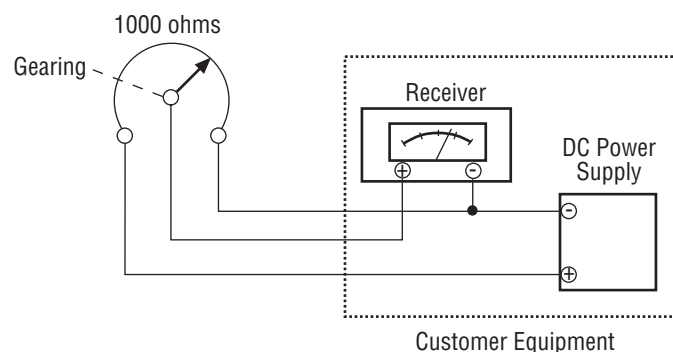

6

Operation

▲ WARNING: Do not manually operate the actuator with devices other than the installed Handwheel and Declutch Lever. Using force beyond the ratings of the actuator and/or using additive force devices such as cheater bars, wheel wrenches, pipe wrenches or other devices on the actuator Handwheel or Declutch Lever may cause serious personal injury and/or damage to the actuator or valve.

CAUTION: Do not motor-operate the valve without first setting or checking the limit switch setting and motor direction. If the valve closes when the open button is pushed, the motor may need to be electrically reversed.

- Do not force the declutch lever into hand operation. If the clutch does not easily engage, rotate handwheel slowly while operating the declutch lever.
 - Do not force the declutch lever into motor operation position. Lever returns to this position automatically when motor is energized.
 - Do not run “plug” type valve against stop.
 - Do not alternately start/stop the motor to open or close a valve that is too tight for normal operation.
-

6.1 Electrical Start-Up

1. Verify that the actuator has been correctly lubricated. This is particularly important if the actuator has been in long-term storage.
2. Verify that the geared limit switch has been correctly set per **Section 5.5.1, Setting Limit Switch**.
3. If the valve stem is not visible, remove the stem cover or handwheel cover plate to observe the output direction of the drive sleeve.
4. Engage manual operation and hand crank the valve well away from end-of-travel positions.
5. Turn on power supply and push the “open” button on the pushbutton station.
6. Check output rotation:
 - If phase rotation is correct, the valve should begin to open.
 - If valve begins to CLOSE, STOP IMMEDIATELY. Incorrect phase rotation will lead to serious damage if the valve seats.

NOTE: *For UEC only* – if incorrect rotation, select opposite direction with dipswitch.
7. Correct the phase rotation one of two ways:
 - switch any two of the three power leads for three-phase power, or
 - reverse the armature leads for DC power.

The actuator should operate correctly and will be stopped at the end-of-travel positions by torque or limit switch functions.

Premature stopping may be caused by incorrect limit switch or torque switch settings or obstructions in the valve.

6.1.1 Typical Wiring Diagrams

Figures 8.1 through **8.4** are representations of typical applications and may not be applicable to your specific actuator. Please refer to the wiring diagram supplied with your actuator to confirm the actual equipment supplied. Check www.limitorque.com for the latest diagram revisions and/or related diagrams.

6.2 Manual Operation

Piece numbers refer to **Figures 8.5, 8.6, and 8.7** for L120-190 and -420, **Figures 8.8, 8.9 and 8.10** for L120-800, and **Figures 8.11 and 8.12** for L120-2000.

The actuator has a handwheel for manual operation. The actuator may be manually operated any time the motor is not engaged.

Manually operate as follows:

1. Move the **Declutch Lever** (piece #10, #11) in the direction of the arrow until it latches into place. Do not force the lever.
2. If the lever will not latch, rotate the **Handwheel** (piece #5) while turning the declutch lever and the lever will latch in place.

When the declutch lever is turned, it rotates a **Cam** which causes the **Clutch Fork** (piece #42-1) to move the **Worm Shaft Clutch** (piece #33) axially along the worm shaft against the force of a **Clutch Spring** (piece #45, #46). This disengages the mating lugs on the **Worm Shaft Gear** (piece #32) and the clutch, and engages the clutch with the **Handwheel Gear** (piece #17, #9). The **Clutch Trippers** (piece # 34-A and 34-B) maintain this position and latch onto the worm shaft gear. Turning the **Handwheel** (piece #5) rotates the **Handwheel Shaft** (piece #18) and the **Handwheel Pinion**. The handwheel pinion then drives the **Handwheel Gear** (piece #8, #9) which in turn drives the clutch. The clutch then drives the actuator in the same manner as in motor operation.

When the motor is energized, the motor pinion will turn the worm shaft gear. Tripper cams mounted on the worm shaft gear cause the trippers to release the clutch. The **Clutch Fork** (piece #42-1) is then forced, under spring pressure, to return the clutch to the motor operation position.

NOTE: The shift from manual operation to motor operation is automatic and does not require external positioning of the declutch shaft.

6.3 Motor Operation

The actuator is always available for motor operation whenever the motor is energized.

CAUTION: Do not force the declutch lever into motor operation. Lever will automatically return to motor operation when the motor is energized.

Reset the travel limit switches prior to motor operation if the actuator has been dismantled or removed from the valve. Piece numbers refer to **Figures 8.5, 8.6, and 8.7** for L120-190 and -420, and **Figures 8.8, 8.9, and 8.10** for L120-800.

In motor operation, the **Motor Pinion** (piece #31) drives the **Worm Shaft Gear** (piece #32), which drives the **Worm Shaft Clutch** (piece #33) through the clutch lugs on both the worm shaft gear and the clutch. The **Worm Shaft** (piece #16-7) is driven by splines on the OD of the worm shaft and on the ID of the clutch. The worm shaft is splined to the **Worm** (piece #30) which drives the **Worm Gear** (piece #12).

Two lugs on the worm gear are engaged by matching grooves in the **Drive Sleeve** (piece #7). This arrangement provides the no-lost-motion mode of operation and allows the worm gear to turn the drive sleeve. The worm gear lugs may also be oriented outside the grooves to give the lost-motion or hammerblow effect. The **Stem Nut** (piece #11) is rotated by internal splines on the ID of the drive sleeve and external splines on the OD of the stem nut. This causes a threaded stem to translate in a threaded stem nut and a keyed shaft to rotate in a keyed stem nut. Thrust is absorbed by **Bearings** (piece #40 and #41) located at the top and bottom of the drive sleeve.

6.4 Torque and Travel Limiting

Unless otherwise stated, piece numbers refer to **Figures 8.5, 8.6, and 8.7** for L120-190 and -420, and **Figures 8.8, 8.9 and 8.10** for L120-800.

The **Geared Limit Switch** (piece #305 of **Figure 8.10**) is driven directly by the worm shaft gear through the limit switch pinion. Thus, the limit switch is directly connected to the output of the actuator and, once properly set, remains in step with the valve position regardless of the electric or manual operation of the actuator.

As the actuator increases torque, the worm and the **Torque Spring Cartridge Assembly** (piece #13) move axially along the worm shaft, compressing the disk spring packs. The torque spring assembly is calibrated such that a finite spring compression relates to a finite output torque. Axial worm movement causes movement of the bearing cartridge that is geared to the **Torque Switch** (piece #300). The torque switch is graduated and adjustable so it may be set to interrupt power to the motor at a predetermined output torque level.

This page is intentionally blank.

7

Maintenance

7.1 Lubrication

The L120 series actuators have a totally sealed gear case, factory-lubricated with grease. The gear case can be mounted in any position.

CAUTION: When the actuator is mounted in an upside-down orientation, the worm may not be completely immersed in lubricant. Check lubricant levels before operating the actuator.

No seal can remain absolutely tight at all times. Therefore, it is not unusual to find a very small amount of weeping around shaft seals—especially during long periods of idleness such as storage. Using grease minimizes this condition as much as possible. If a small amount of lubricant is weeping at start-up, remove it with a clean cloth. Once the equipment is operating on a regular basis, the weeping should stop.

7.1.1 Lubrication Inspection

Inspect Limatorque L120 series actuators for correct lubrication prior to operating—particularly following a long storage period.

Each application has its own effect on the actuator. The frequency of these inspections should be based on the application and the operating experience. The following lubrication inspection schedule is *recommended* until operating experience indicates otherwise.

For Gear Case, inspect lubrication every 18 months or 500 cycles, whichever occurs first.

During an inspection, consider the following:

- **Quantity** – Ensure there is enough lubricant so that the Worm and the Worm Gear are totally immersed in grease regardless of the position.
- **Quality** – Inspect lubricant for dirt, water or other foreign matter. If any one of these is found:
 1. Flush the actuator with a commercial degreaser/cleaner such as Exxon Varsol #18. This degreaser/cleaner is not corrosive and does not affect the seal materials.
 2. Repack the actuator with fresh lubricant, allowing room for grease thermal expansion.
- **Consistency** – Ensure the lubricant is fluid approximating a standard NLGI-00 grade consistency or less. Thinners such as Amoco WAYTAC #31 oil may be added provided the volume of thinner does not exceed 20% of the total lubricant.

7.1.2 Factory Lubricant

Gear Case

- The L120-190 through 2000 is factory-lubricated with an NLGI Grade 00 lithium-base grease, suitable for temperatures from 0°F to 225°F (-18°C to 107°C).

Geared Limit Switch

- Mobil 28 (No Substitute)

Table 7.1 – Lubricant Weights

Actuator Size	lb.	kg
L120-190	15	5.6
L120-420	50	18.7
L120-800 Drive 1	71	26.5
L120-800 Drive 2	75	28
L120-2000 Drive 1	65	24.3
L120-2000 Drive 2	72	26.9

7.1.3 Minimum Lubricant Qualities Required

The standard lubricants used by Limitorque have been proven to be extremely reliable over years of service. Limitorque does not recommend a particular lubricant substitute for the standard lubricants; however, Limitorque does require the following lubricant qualities as a minimum.

CAUTION: Do not mix lubricants of a different base chemical. Mixing lubricant bases may cause lubricant properties to be ineffective.

The lubricant must:

- Contain an “EP” additive.
- Be suitable for the temperature range intended.
- Be water and heat-resistant and non-separating.
- Not create more than 8% swell in Buna N or Viton.
- Not contain any grit, abrasive, or fillers.
- Comply with a slump-prefer NLGI-00 grade.
- Not be corrosive to steel gears, ball, or roller bearings.
- Have a dropping point above 316°F (158°C) for temperature ranges of 0°F to 225°F (-18°C to 107°C).

7.2 Disassembly and Reassembly

CAUTION: Turn off all power services before attempting to perform service on the actuator.

- **Remove the actuator from the valve for complex work. Minor work, such as replacing geared limit switch, torque switch or motor, may be readily performed while the actuator is still on the valve.**
 - **Potential High Pressure Vessel. Before removing or disassembling your actuator, ensure that the valve or other actuated device is isolated and is not under pressure.**
-

7.2.1 Disassembling Actuator Sizes L120-190, -420, and -800

The disassembly of the actuator L120–190 will be used as a general example. Always refer to the parts drawing when disassembling. Be certain to keep all parts clean and free from dirt after disassembly.

Unless otherwise noted, piece numbers refer to **Figures 8.5, 8.6 and 8.7** for L120-190 and -420, and **Figures 8.8, 8.9 and 8.10** for L120-800.

1. Turn off power to the actuator.
2. Open or remove electrical **Compartment Cover** (piece #200-1).
3. Disconnect all electrical leads from the **Torque Switch** (piece #300) and **Geared Limit Switch** (piece #305). Ensure that all leads and terminals are clearly marked to facilitate reassembly.
4. Remove two screws holding limit switch and one holding torque switch. Remove both items.
5. Remove four bolts holding **Motor** (piece #31) and three bolts holding conduit **Nipple Flange** (piece #124-1). Remove motor, drawing motor leads through the conduit opening.
6. Replace **Motor Pinion** (piece #31). The motor pinion is keyed to the motor shaft and held there with a setscrew and lockwire to retain the pinion in its proper position. The motor pinion should be shouldered on the motor shaft.
7. Remove **Handwheel** (piece #5) by loosening setscrew. Handwheel can then be pulled from **Handwheel Shaft** (piece #18).
8. Remove **Declutch Lever Subassembly** (piece #10) by removing **Extension Spring** (piece #48), **Retaining Ring** (piece #53-4), **Declutch Link** (piece #9), and two hex head cap screws holding the subassembly in place. Remove subassembly.
9. **Remove Spring Cartridge Cap** (piece #4).
10. Remove **Worm and Torque Spring Subassembly** (piece #13 and #30) completely. Temporarily replace the handwheel and then rotate in the close direction to cause the worm to screw out of engagement with worm gear and cause the torque spring cartridge to emerge from housing. See Step No. 21 to further disassemble the cartridge.
11. Remove **Housing Cover** (piece #3).

▲ WARNING: Do not remove if a thrust load is on the actuator or if the valve is under pressure and not fully open, as personal injury may result.

12. Lift complete drive sleeve assembly from actuator housing. The drive sleeve assembly consists of **Locking Nut** (piece #39), **Stem Nut** (piece #11), **Drive Sleeve** (piece #7), **Upper Thrust Bearings** (piece #40 and #67), **Worm Gear** (piece #12), **Worm Gear Spacer** (piece #36) and **Lower Thrust Bearing** (piece #14). The drive sleeve assembly may be further dismantled if required by pressing off **Lower Drive Sleeve Bearing** (piece #41).
13. Remove **Retaining Ring** (piece #53-1), **Split Ring Retainer** (piece #27) and **Conduit Nipple** (piece #23). Pull the **Worm Shaft Clutch Gear** (piece #32) from the worm shaft.
14. Spread clutch trippers with a tool to shift actuator into motor operation.

▲ WARNING: Do not use hands as spring forces could result in personal injury.

15. Remove bolts holding **Declutch Housing** (piece #2) to **Housing** (piece #1). Remove clutch housing, **Trippers** (piece #34-A and #34-B), and **Clutch Fork Assembly** (piece #42-1). **Worm Shaft Clutch** (piece #33) will slide off worm shaft when removing clutch housing.
16. Slide **Clutch Spring** (piece #45) off worm shaft toward motor end.
17. Remove **Elastic Stop Actuator** (piece #16). Pull **Handwheel Spur Gear** (piece #8) that is keyed to **Shaft** (piece #16-7).
18. Remove bolts holding **WS Bearing Cap** (piece #6) and slide cap off wormshaft. Remove **Handwheel Clutch Pinion** (piece #17) from bearing cap by removing **Retaining Ring** (piece #53-3). Be careful not to lose **NW Pinion Spring** (piece #47) and **Spring Ring** (piece #49).
19. Remove Handwheel shaft: tap on the motor end of the shaft to free **Ball Bearing** (piece #52-1) from housing. Handwheel shaft will break free from **Ball Bearing** (piece #52-6). Remove handwheel shaft from housing.
20. Withdraw handwheel shaft from handwheel end of housing.
21. To disassemble worm assembly further (removed in Step No. 10), remove **Elastic Stop Nut** (piece #16), noting the number of turns to remove.
22. Remove **Thrust Washers** (piece #46-2), **Limit Sleeve** (piece #20-5), and **Belleville Disc Springs** (piece #16-3 and #16-4). Note the orientation of the discs for reassembly later.
23. Remove **Retaining Ring** (piece #53-4).
24. The **Bearing Cartridge** (piece #16-1) and **Worm Subassembly** (piece #30-1) can now be withdrawn.
25. Remove the **Ball Bearing** (piece #52-7), locate setscrew in bearing locknut and remove setscrew and **Locknut** (piece #44-1).

7.2.2 Reassembling Actuator Sizes L120-190, -420 and -800

Piece numbers refer to **Figures 8.5, 8.6 and 8.7** for L120-190 and -420, and **Figures 8.8, 8.9 and 8.10** for L120-800.

1. Follow the disassembly instruction for Actuator Sizes 190, 420, and 800 in the reverse order and follow the gasketing instructions below.
2. Stack Belleville disc, thrust washers, and spacers that were removed in the exact order as they were removed.
3. Re-install **Elastic Stop Nut** (piece #16) with the same number of turns used to remove.
4. For the **Worm Shaft Clutch** (piece #33), install the clutch with smaller set of lugs first to engage with lugs on **Handwheel Clutch Pinion** (piece #17).
5. For worm, rotate **Worm Shaft Clutch** (piece #33) to engage splines on worm shaft. Place actuator in manual operation, replace **Declutch Lever Subassembly** (piece #10), and handwheel temporarily; rotate handwheel in opposite direction used to remove worm.
6. When re-installing the **Motor Pinion** (piece #31), ensure it fits tightly on the motor shaft (preferably a light press fit).

7.2.2.1 To Replace Stem Nut Only

If the **Stem Nut** (piece #11) is to be removed from the assembled actuator, remove the Locking Nut (piece #39) and lift out top of nut.

▲ WARNING: Do not remove Locknut (piece #39) with actuator under load or with valve under pressure. See Warning on Step No. 11 of Section 7.2.1, Disassemble Actuator Sizes L120-190, -420, and -800.

1. The **Locknut** (piece #39) is staked in two places. Locate the stakes and spot with a drill.
2. Clean all metal particles and remove.
3. If the actuator is mounted on a valve having a threaded stem, and removal of the stem nut is required, perform Step No.1 and rotate the handwheel to close the valve.
4. The stem nut will rise up the threaded valve stem. When the stem nut splines are free from the drive sleeve, rotate the stem nut by hand the remaining length of the valve stem.
5. Replace if necessary.
6. Install the new stem nut with the locknut.
7. Stake the top threads of the locknut in two places.

NOTE: If the valve must be left in service while the stem nut is replaced, the valve stem must be locked in such a way as to prevent any movement of the valve stem.

7.2.2.2 Gaskets

All gaskets, except the housing cover gaskets, are 1/32" thick Anchorite. The housing cover gaskets vary in thickness. Determine the correct size as follows:

1. Clean both housing cover and main housing gasketed surface.
2. Install actuator drive sleeve assembly complete with bearings.
3. Install housing cover and measure the gap between the housing cover and the main housing.
4. Add 10% to the measurement. Use the closest nominal gasket thickness or combination available.

7.2.3 Disassembling Actuator Size 2000 Drive 1 and Drive 2

The L120-2000 Drive 2 is a thrust-type actuator consisting of an L120-2000 Drive 1 torque-type actuator mounted on a thrust bearing assembly. For torque-only actuators see **Section 7.2.3.2, Drive 1 (Torque Actuator)**.

Piece numbers refer to **Figures 8.11** and **8.12**.

7.2.3.1 Drive 2 (Thrust Actuator Only)

▲ WARNING: Before proceeding, ensure that the actuator is not under load and that the valve is not under pressure. If so, the valve must be in fully open position.

Remove **Drive Sleeve Locknut** (piece #130):

1. Rotate handwheel to close valve, causing the **Stem Nut** (piece #127) to rise up threaded valve stem until the stem nut splines are free of **Drive Sleeve** (piece #126).
2. Rotate stem nut by hand for the remaining length of the valve stem and remove.

Remove **Thrust Adapter** (piece #125):

NOTE: If disassembly of thrust adapter assembly is not required, continue to **Section 7.2.3.2, Drive 1 (Torque Actuator)**, Step No. 1.

1. Remove **Seal Retainer Plate** (piece #129) and **Oil Seal** (piece #54-6).
2. Loosen setscrew and remove **Thrust Bearing Cartridge** (piece #128) from the **Thrust Adapter Housing** (piece #125).
3. Remove **Upper Bearing Roller Assembly** (piece #131).
4. Lift **Thrust Drive Sleeve** (piece #126) out of **Thrust Adapter Housing** (piece #125).
5. Remove **Lower Bearing Roller Assembly** (piece #131).

7.2.3.2 Drive 1 (Torque Actuator)

1. Remove **Limit Switch Compartment** (piece #200-1).
2. Disconnect motor leads, **Torque Switch** (piece #301) leads, and **Geared Limit Switch** (piece #305) leads.
NOTE: Ensure leads are labeled for reassembly.
3. Remove torque switch and geared limit switch.
4. Using lifting eyebolts, remove **Housing Cover** (piece #3), **Drive Sleeve** (piece #41), and **Worm Gear** (piece #13).
5. Remove **Handwheel Washer** (piece #88). Pull off **Handwheel** (piece #5) and **Handwheel Clutch** (piece #83) from **Handwheel Shaft** (piece #18).
6. Remove **Worm Shaft End Cap** (piece #4) and **Declutch Housing Cover** (piece #86).
7. Remove Declutch Assembly:
 - A. Remove **Declutch Stop** (piece #93), **Tripper Spring** (piece #58), **Trippers** (piece #34-A and #34-B) and **Roll Pin** (piece #19-7).
 - B. Loosen setscrews on **Declutch Lever** (piece #11) and **Collar** (piece #56-8). Remove declutch lever, **Declutch Shaft and Cap** (piece #95), and **Slide Declutch Shaft** (piece #19-1) out through bottom of actuator.
 - C. Remove **Declutch Fork** (piece #42-1), and other **Declutch Shaft-Mounted Components** (piece #19-2, #91, #92, and #56-8).
 - D. Remove **Handwheel Shaft and Pinion** (piece #18).
8. Remove **Drive Shaft** (piece #71) and **Flexible Jaw Clutch** (piece #82-1) as integral assembly. Remove **Gear Clutch Spacer** (piece #78), **Sliding Clutch Gear** (piece #33), and **Clutch Compression Spring** (piece #46).
9. Remove **Splined Insert** (piece #87) using jack screws. Remove **Spirolox Ring** (piece #53-8) and **Handwheel Gear** (piece #9).
10. Remove **Gear Mounting Bracket** (piece #84) using jack screws, **Bearing** (piece #52-9), and **Bearing Adapter** (piece #79).
11. Pull **Hollow Drive Shaft** (piece #17) toward declutch end and remove **Spirolox Ring** (piece #53-8).
12. Remove **Declutch Housing** (piece #2).
13. Remove **Hollow Drive Shaft** (piece #17):
 - A. Push hollow drive shaft toward motor end. Loosen setscrew and remove **Bearing Locknut** (piece #80-1) – hold hollow drive shaft using adjustable spanner on splines.
 - B. Remove **Bearing** (piece #52-8) by pushing hollow drive shaft toward declutch end.
 - C. Remove **Gear Limit Thread Collar** (piece #76) and key.
 - D. Remove hollow drive shaft from declutch end of actuator.
14. Loosen setscrew in **Cartridge Stem Locking Nut** (piece #16-10) and replace **Declutch Housing** (piece #2) with two screws to compress torque spring.
15. Remove **Locking Nut** (piece #16-10).

CAUTION: Declutch Housing is under spring load.

16. Remove **Declutch Housing** (piece #2):
 - A. Pull **Bearing Cartridge** step (piece #16-8) out partially.
 - B. Remove **Thrust Washers** (piece #16-2), **Torque Limit Sleeve** (piece #16-5) and **Springs** (piece #16-3).

17. Remove bearing cartridge/worm assembly from actuator. To disassemble further:
 - A. Loosen two setscrews on **Bearing Cartridge Cap** (piece #16-1), and unscrew **Bearing Cartridge Stem** (piece #16-8).
 - B. Slide bearing cartridge cap off toward worm threads.
 - C. Loosen setscrew and remove **Bearing Locknut** (piece #44-1).
 - D. Press off two **Bearings** (piece #73).
18. Remove motor, **Motor Adapter** (piece #22), **Intermediate Pinion and Gear Assembly** (piece #32-1, and #32-2) as an integral assembly. Remove **Drive Shaft Gear** (piece #32-2) and **Bearing Spacer** (piece #101).

7.2.4 Reassembling Actuator Size 2000 Drive 1 (Torque Actuator)

1. Press two **Bearings** (piece #73) onto worm. It may be necessary to apply heat to the bearings. Ensure that the bearing spacer is installed.
2. Install **Bearing Lock Nut** (piece #44-1) and tighten screw.
3. Apply head to **Bearing Cartridge Cap** (piece #16-1) and drop on bearing from worm end. Ensure that cartridge cap seats on bearing.
4. Install bearing cartridge/worm assembly in housing.
5. Replace the following in the order listed:
 - A. **Thrust Washer** (piece #16-2)
 - B. **Belleville Springs** (piece #16-3)
 - C. **Torque Limit Sleeve** (piece #16-5)
 - D. **Thrust Washer** (piece #16-2)
 Ensure flat side of thrust washer is against springs.
6. Thread **Cartridge Stem Nut** (piece #16-10) onto **Bearing Cartridge Stem** (piece #16-8) by hand.
7. Slide bearing cartridge/worm assembly into housing.
8. Install **Hollow Drive Shaft** (piece #17).
9. Install **Gear Limit Threaded Collar** (piece #76) and key on motor end of hollow drive shaft with threaded end toward worm.
10. Slide **Bearing** (piece #52-8) onto shaft.
11. Thread **Bearing Locknut** (piece #81-1) on shaft and tighten setscrew. Hold Drive Shaft using adjustable spanner on splines.
12. Re-install motor as follows:
 - A. Push **Hollow Drive Shaft** (piece #17) to declutch and install **Bearing Spacer** (piece #101).
 - B. Install motor gearing by meshing **Drive Shaft Gear** (piece #32-2) and **Intermediate Pinion** (piece #32-1) and pressing combined assembly into housing bores.
 - C. Install motor gear shims in motor adapter bearing bores and install **Motor Adapter Gasket** (piece #105) and **Motor Adapter** (piece #22). Tap adapter to ensure bearings seat.
 - D. Check intermediate pinion and shaft for proper shims.
 - E. Install motor.
13. Re-install declutch housing as follows:
 - A. Install **Spirolox Ring** (piece #53-8) on **Hollow Drive Shaft** (piece #17).
 - B. Install **Declutch Housing** (piece #2) using two screws only to compress **Belleville Spring Set** (piece #16-3).
 - C. Using two screws, thread **Cartridge Stem Nut** (piece #16-10) on **Bearing Cartridge Stem** (piece #16-8) until nut is snug against **Thrust Washer** (piece #16-2).
 - D. Re-install declutch housing.
14. Install **Bearing Mounting Bracket Assembly** (piece #84, 79, and 52-7).
15. Install **Handwheel Gear** (piece #9) and **Spirolox Ring** (piece #53-8).
16. Install **Splined Insert** (piece #87), **Spring Washer** (piece #49) and **Clutch Compression Spring** (piece #46).
17. Install **Sliding Gear Clutch** (piece #33) onto **Hollow Drive Shaft Splines** (piece #17).

18. Install **Drive Shaft** (piece #77), ensuring that **Gear Clutch Spacer** (piece #78) is in place. Align splines on drive shaft and drive shaft gear and push drive shaft into actuator from declutch end.
19. Mount **Bearing** (piece #52-6 and #52-1) on **Handwheel Shaft and Pinion** (piece #18) and install assembly into actuator.
20. Install **Declutch Shaft** (piece #19-1) and **Torsion Spring** (piece #94) into **Declutch Cap** (piece #95).
21. Install declutch shaft assembly through bottom of **Declutch Housing** (piece #2). Declutch shaft assembly consists of:
 - Declutch Shaft
 - Torsion Spring
 - Declutch Cap
 - Declutch Lever Drum (piece #19-3)
 - Declutch Arm (piece #19-2)
 - Declutch Shaft Washers (piece #91, 3 pieces)
 - Declutch Fork (piece #42-1)
 - Declutch Spacer (piece #92)
 - Hallowell Collar (piece #56-8)
- NOTE: Declutch shaft must be installed with key seat facing right side of the declutch housing when viewed from declutch end of actuator.
22. Fasten declutch cap.
23. Insert **Roll Pin** (piece #19-7) through declutch arm and shaft.
24. Ensure that declutch shaft bears against declutch cap, push collar against top of housing, and tighten collar setscrew.
25. Ensure that **Oil Seal** (piece #54-8) is in place.
26. Install **Declutch Lever** (piece #11) and tighten setscrew.
27. Rotate declutch lever clockwise, hold in position, and install **Declutch Lever Stop** (piece #93).
28. Install **Clutch Tripper** (piece #34-A, 34-B) and **Tripper Spring** (piece #58).
29. Install **Declutch Housing Cover** (piece #3) and **Declutch Cover Gasket** (piece #54-11).
30. Ensure that **Handwheel Oil Seal** (piece #54-8) is in place.
31. Install **Worm Shaft End Cap** (piece #4) and **WS End Cap Gaskets** (piece #54-2).
 - NOTE: Ensure that the same number of gaskets is installed as were removed during disassembly. Thickness of gaskets must be sufficient to prevent end cap from bearing on drive shaft.
32. Install **Worm Gear** (piece #13).
33. Install **Torque Bearing Sleeve** (piece #8) and **Drive Sleeve Thrust Bearing** (piece #40).
34. Apply fresh, clean lubricant in actuator housing. For quantity see **Section 7.1, Lubrication**.
35. Install **Housing Cover Gasket** (piece #54-7) and **Housing Cover** (piece #3).
36. Install **Handwheel Clutch** (piece #83), **Handwheel** (piece #5), and **Handwheel Washer** (piece #88) on **Handwheel Shaft and Pinion** (piece #18).
37. Install **Torque Switch** (piece #301) and **Geared Limit Switch** (piece #305).
38. Connect motor leads and leads to torque switch and geared limit switch.

7.2.5 Reassembling Actuator Size 2000 Drive 2 (Thrust Actuator Only)

1. If **Thrust Adapter Assembly** (piece #125) is not disassembled, go to Step No. 7.
NOTE: Thrust bearing races should be pressed on **Thrust Drive Sleeve** (piece #126), in **Thrust Adapter Housing** (piece #125), and **Thrust Bearing Cartridge** (piece #128) prior to beginning assembly procedure.
2. Install **Lower Bearing Roller Assembly** (piece #131) in **Thrust Adapter Housing** (piece #125).
3. Install short end of **Thrust Drive Sleeve** (piece #126) into **Thrust Housing** (piece #125).
4. Install **Upper Bearing Roller Assembly** (piece #131) on the **Thrust Drive Sleeve** (piece #126).
5. Install **Thrust Bearing Cartridge** (piece #128), thread tight, or until drag is felt on thrust drive sleeve and tighten screw.
6. Install **Oil Seal** (piece #54-6) and **Seal Retainer Plate** (piece #129).
7. Lift actuator or turn upside down. Install **Housing Thrust Adapter Assembly** (piece #125). Ensure that **Thrust Drive Sleeve O-Ring** (piece #134) is in place.
8. Install **Stem Nut** (piece #127).
9. Install **Drive Sleeve Locknut** (piece #130) and crimp or stake the top threads to two places.

▲ WARNING: Drive sleeve locknut has left-hand threads and must be rotated counterclockwise.

This page is intentionally blank.

8

Standard Wiring and Parts Diagrams

Figure 8.1 – Wiring Diagram – No Controls

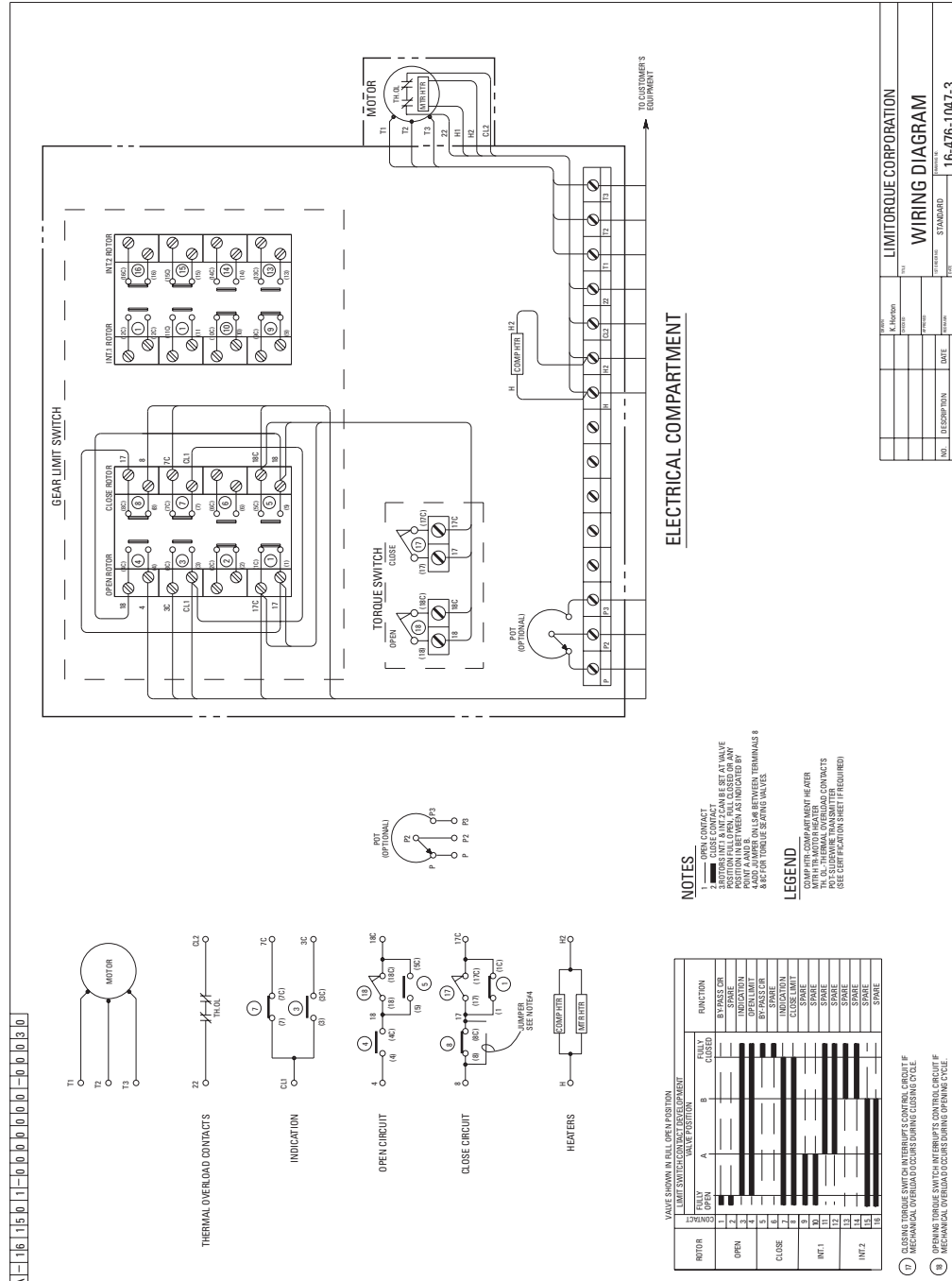

Figure 8.3 – Wiring Diagram – NCU

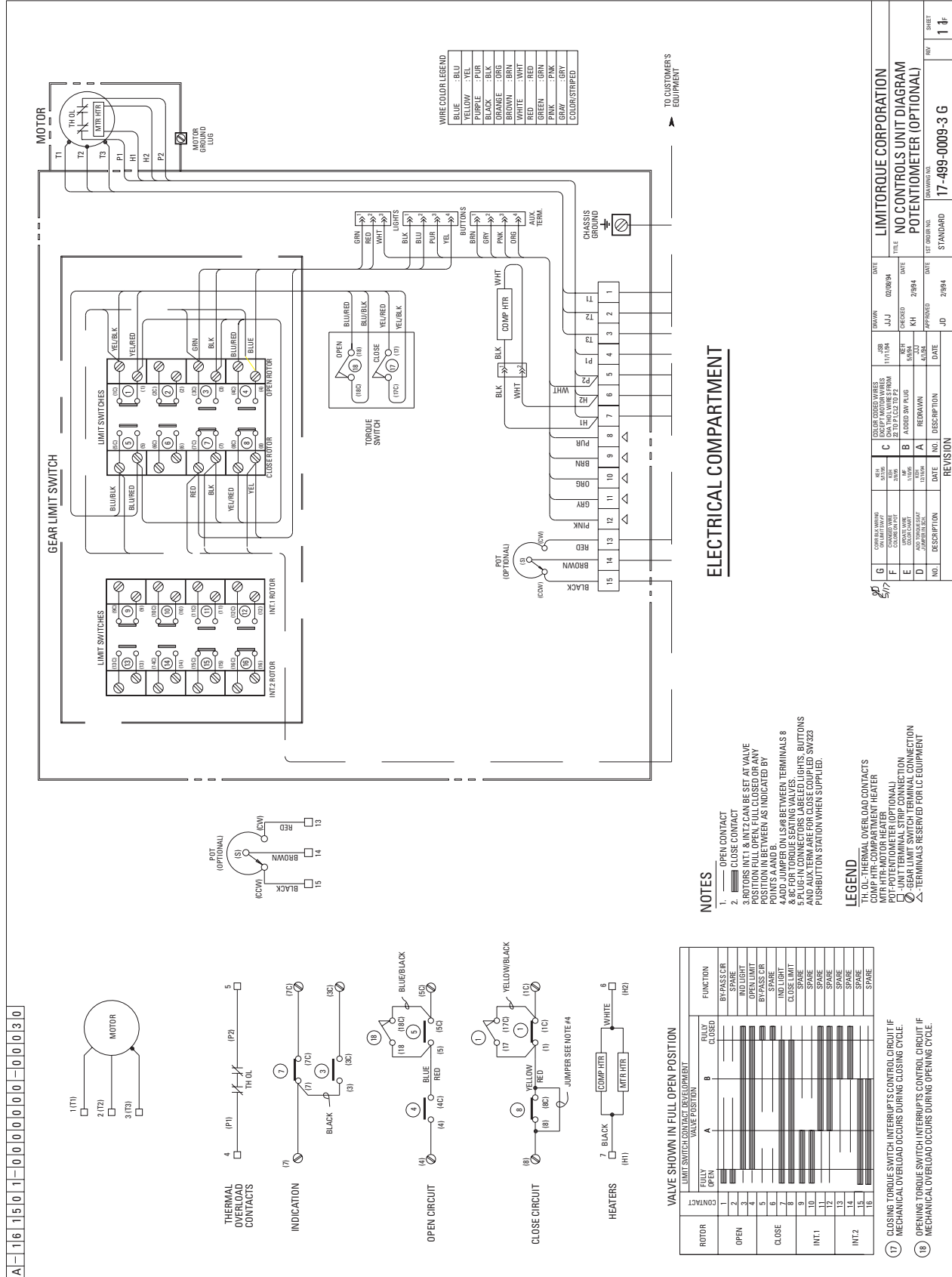

Figure 8.5 – L120-190 and -420 (Refer to **Table 8.1** for parts list)

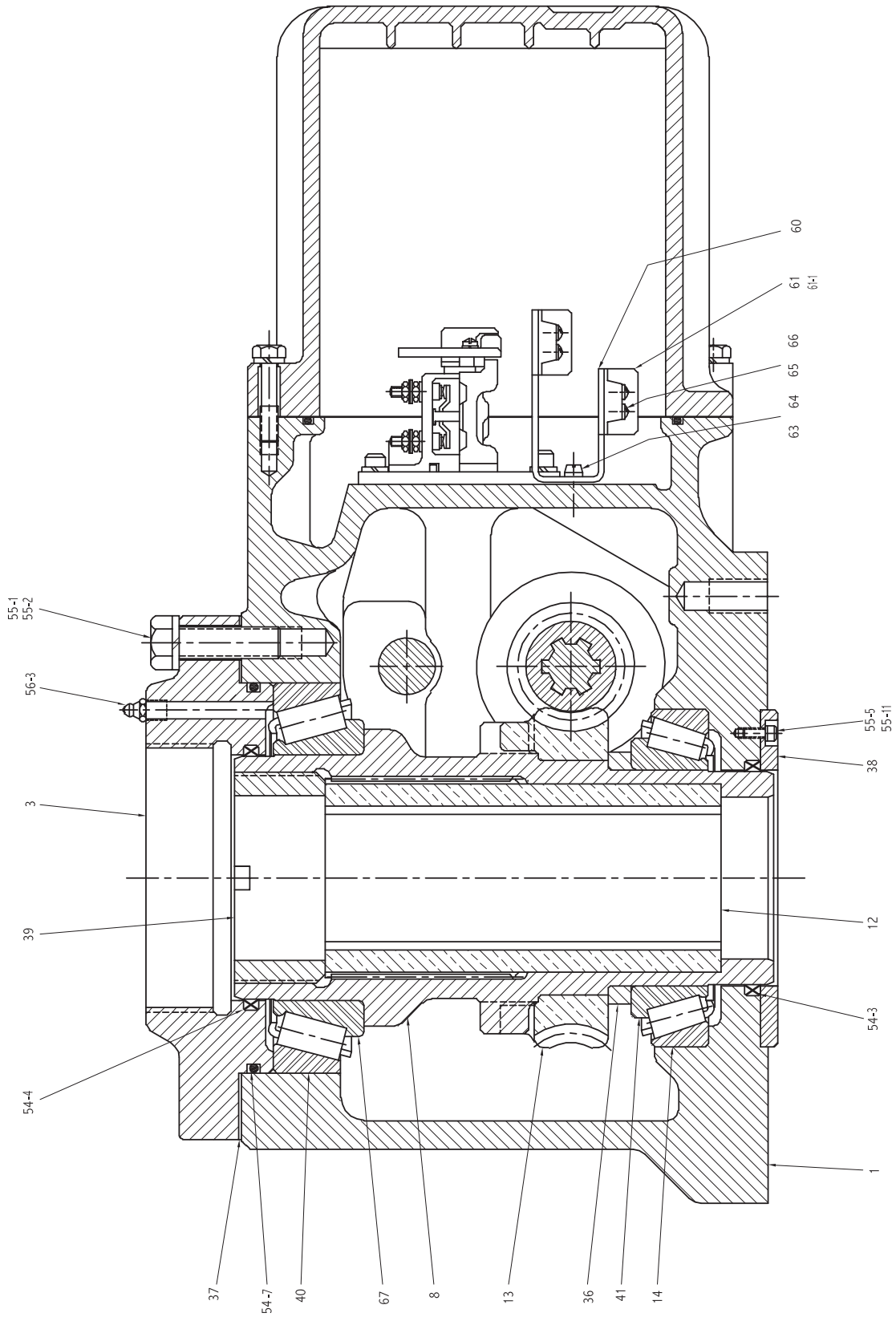

Figure 8.6 – L120-190-and 420 (Refer to **Table 8.1** for parts list)

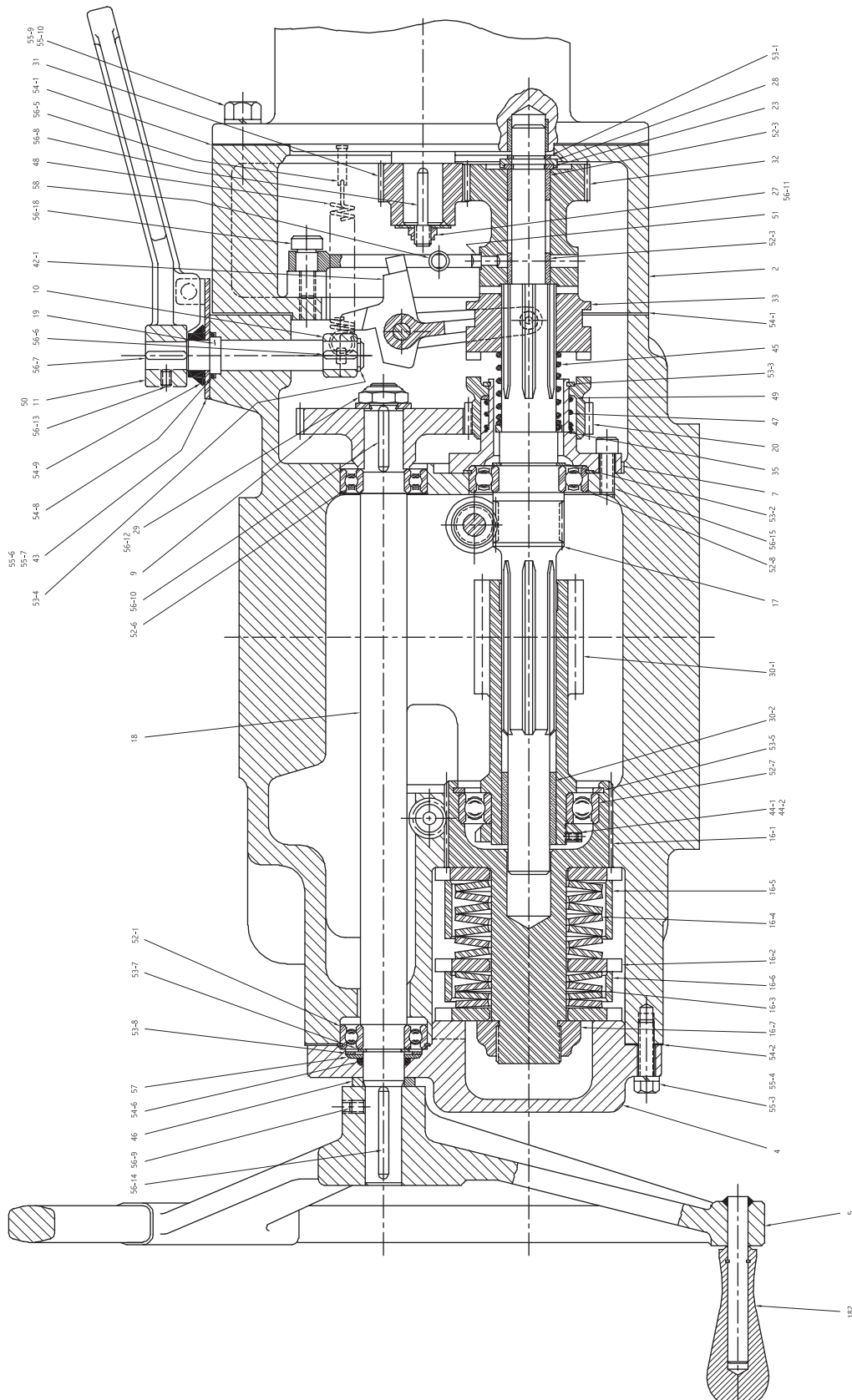

Figure 8.7 – L120-190 and -420 (Refer to **Table 8.1** for parts list)

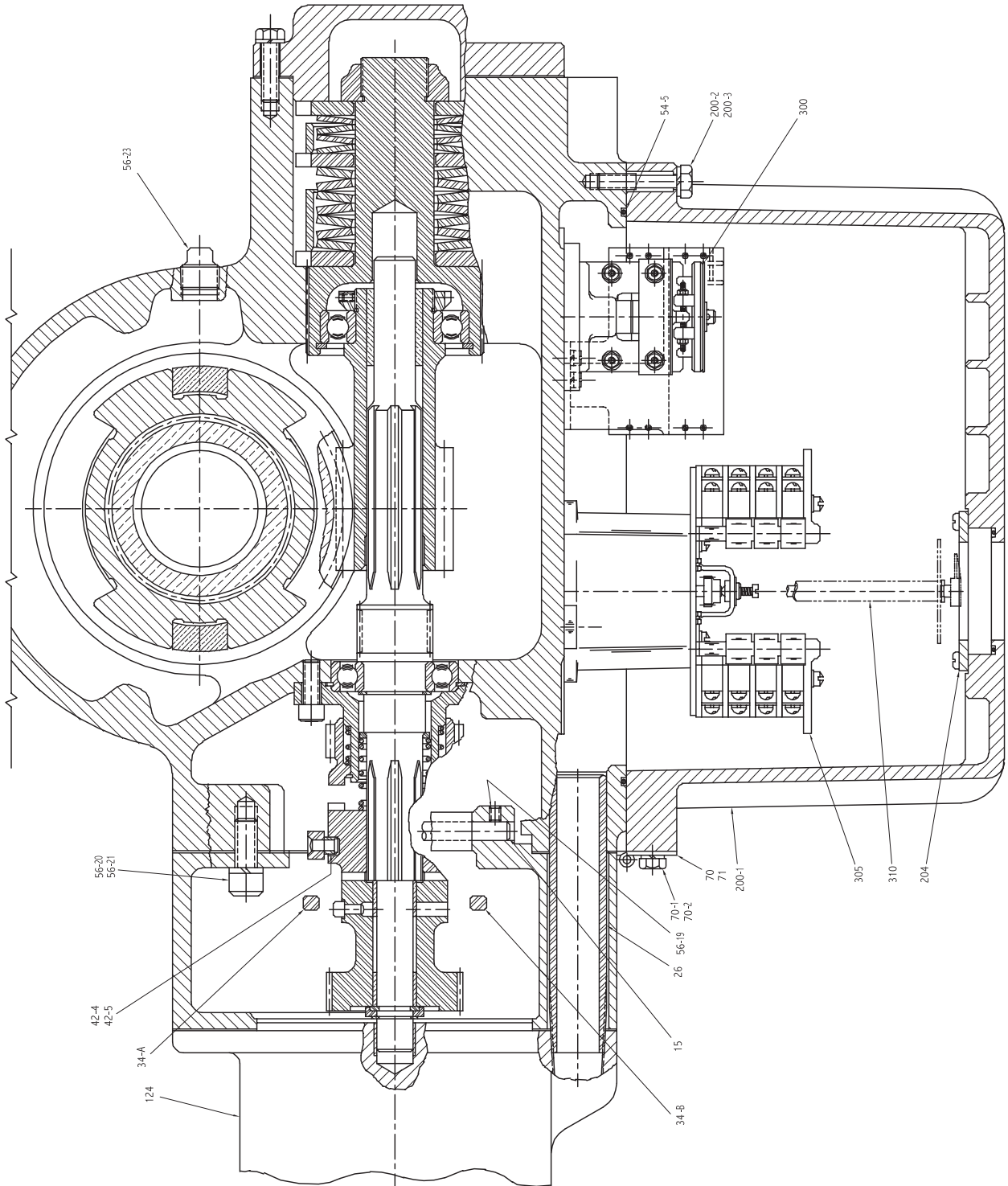

Figure 8.8 – L120-800 (Refer to **Table 8.1** for parts list)

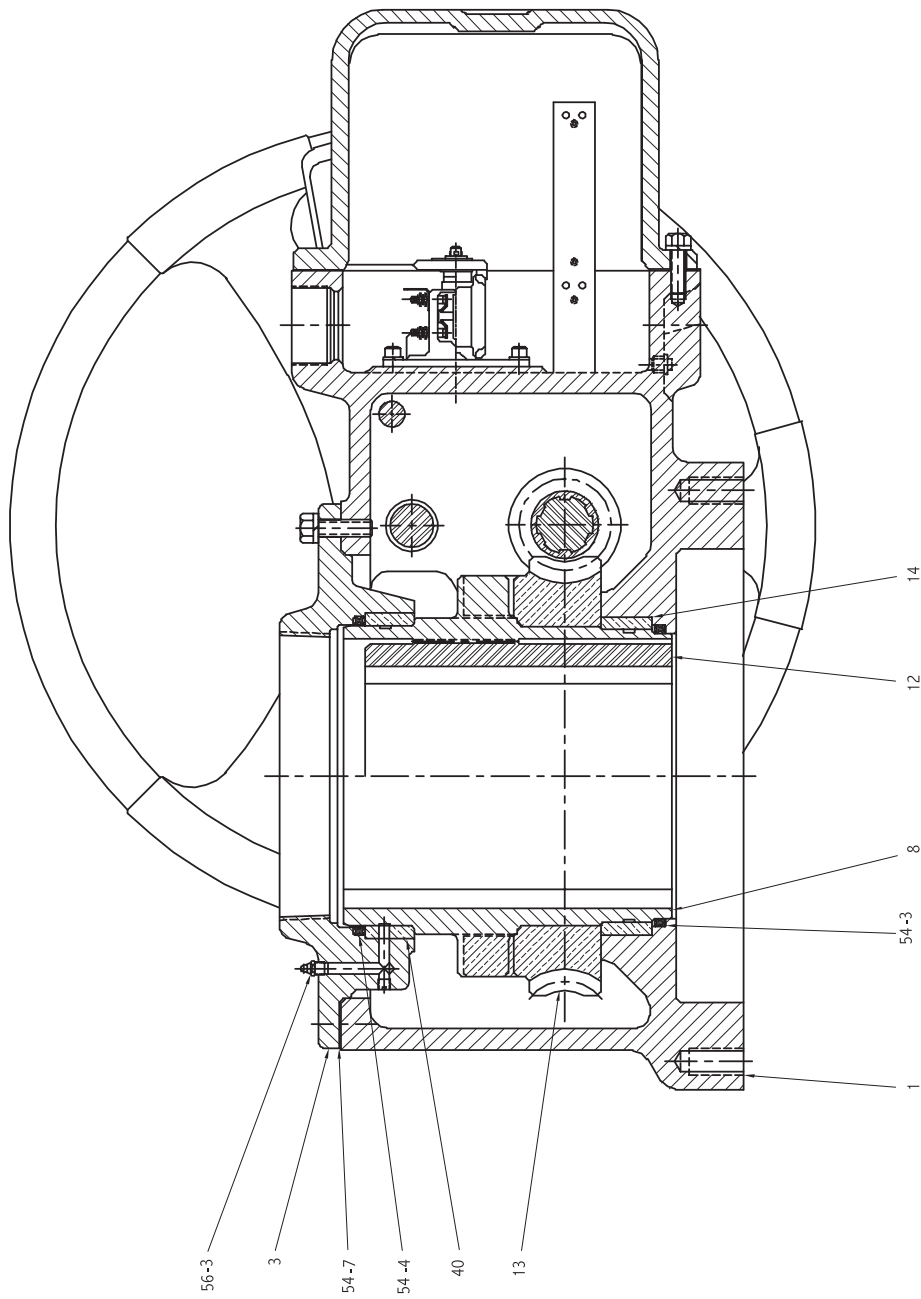

Figure 8.9 – L120-800 (Refer to **Table 8.1** for parts list)

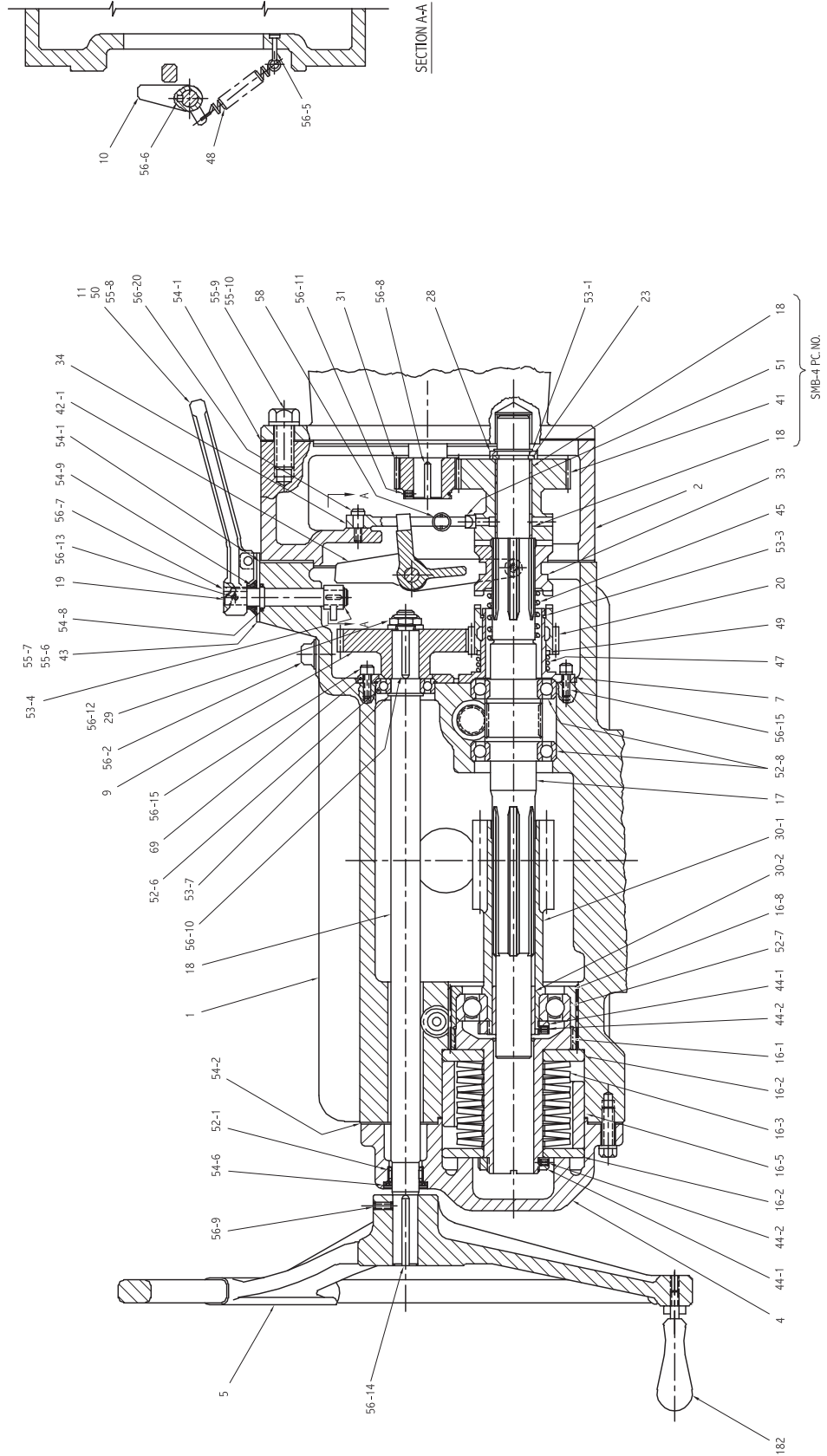

Figure 8.10 – L120-800 (Refer to **Table 8.1** for parts list)

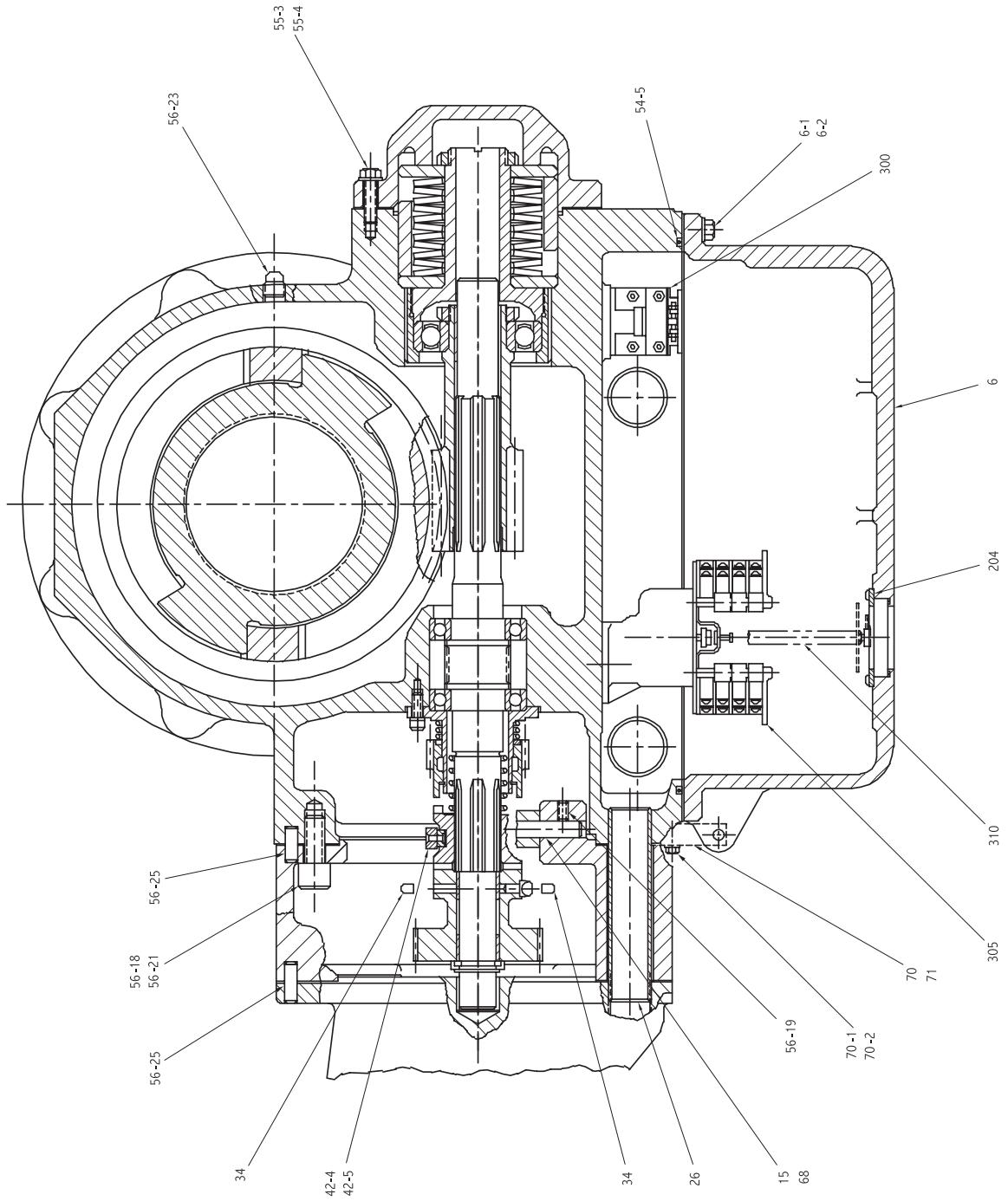

Table 8.1 – L120-190, -420 and -800 typical parts list)

Piece No.	Description	Piece No.	Description
1	Housing	53-2	Retaining Ring
2	Declutch Housing	53-3	Retaining Ring
3	Housing Cover	53-4	Retaining Ring
4	Spring Cartridge Cap	54-1	Declutch Housing Gasket
5	Handwheel	54-2	Spring Cartridge Cap Gasket
7	Worm Shaft Bearing Cap	54-3	Quad Ring
8	Drive Sleeve (2 Pc)	54-4	Quad Ring
9	Handwheel Spur Gear	54-5	O-Ring
10	Declutch Link	54-6	O-Ring
11	Declutch Lever	54-7	O-Ring
12	Stem Nut (BR2)	54-8	O-Ring
13	Worm Gear	54-9	Chekseal
14	Lower Thrust Bearing Cup	55-1	Hex Head Cap Screw
16	Elastic Stop Nut	55-2	Hex Head Cap Screw
16-7	Worm Shaft	55-3	Hex Head Cap Screw
17	HW Clutch Pinion	55-5	Socket Head Cap Screw
18	HW Shaft	55-6	Hex Head Cap Screw
20	Handwheel Gear	56-1	Pipe Plug
23	Split Ring	56-2	Pipe Plug
26	Flexloc Nut	56-3	Grease Fitting
27	Split Ring Retainer	56-5	Clevis Pin
28	Locking Nut	56-6	Key
29	Worm Bushing	56-7	Key
30	Worm	56-8	Key
31	Motor Pinion	56-9	Key
32	Worm Shaft Gear	56-10	Key
33	Worm Shaft Clutch	56-11	Flatwasher
34-A	Clutch Tripper #1	56-12	Flatwasher
34-B	Clutch Tripper #2	56-13	Socket Head Setscrew
35	Spring Spacer	56-14	Cup PT Setscrew
36	Worm Gear Spacer	56-16	Socket Head Cap Screw
39	Locking Nut	56-18	Socket Head Screw
40	D.S. Bearing Cup	56-19	Socket Head Setscrew
41	D.S. Bearing Cone	56-20	Socket Head Setscrew
42-1	Clutch Fork Assembly	56-21	Lockwasher
44-1	Locknut	56-22	Pipe Plug
44-2	Setscrew	56-23	Pipe Plug
45	Clutch Spring	67	Bearing Cone
46-2	Thrust Washers	124	Motor
47	NW Pinion Spring	124-1	Nipple Flange
48	Extension Spring	200-1	Limit Switch Compartment Cover
49	Spring Ring	200-2	Captivated Screw
52-1	Ball Bearing	200-3	Lockwasher
52-6	Ball Bearing	300	Torque Switch
52-7	Ball Bearing	305	Geared Limit Switch
52-8	Ball Bearing	67	Bearing Cone
53-1	Retaining Ring		

Figure 8.12 – L120-2000 (Torque Base) (Refer to **Table 8.2** for parts list)

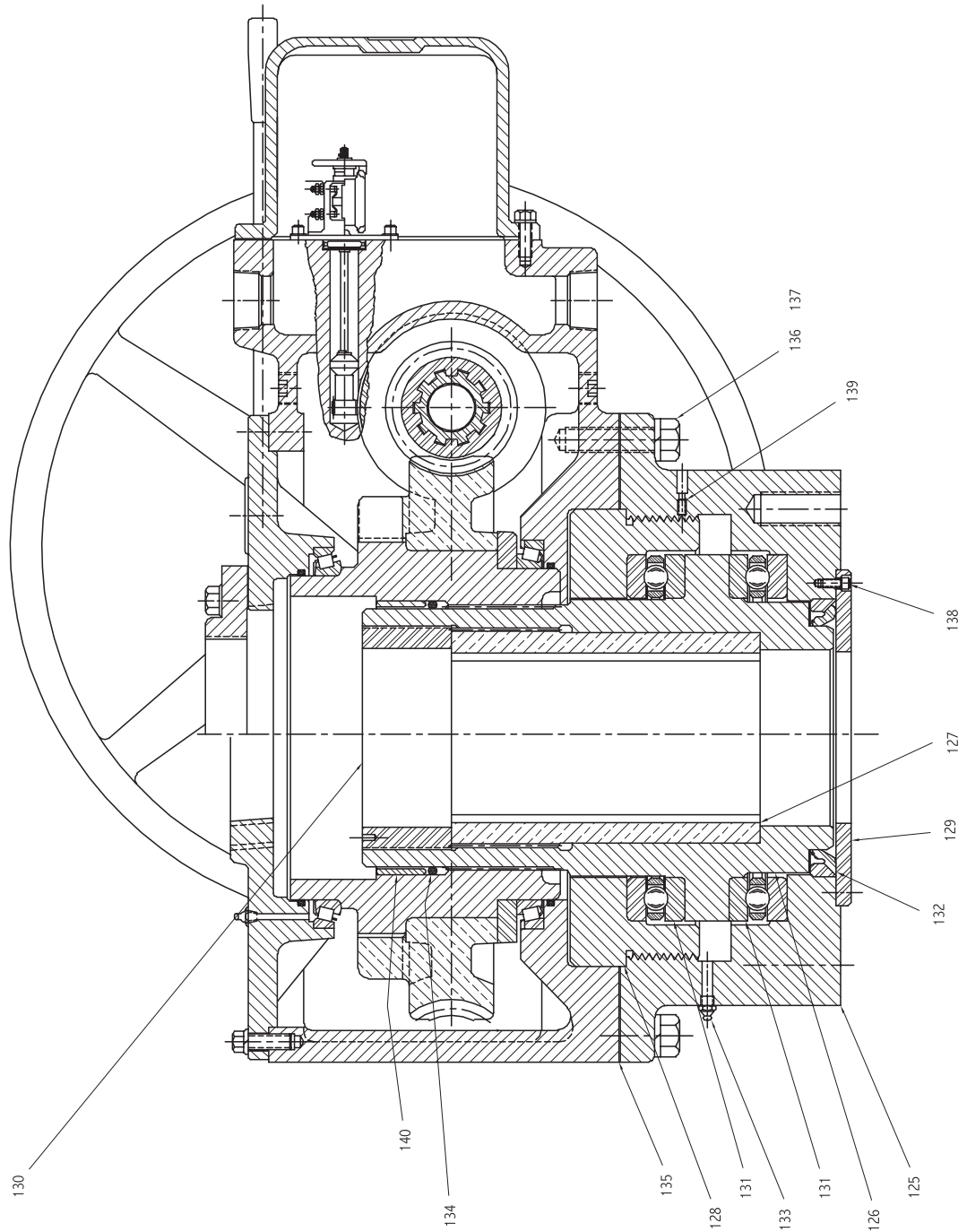

Table 8.2 – L120-2000 typical parts list

Piece No.	Description	Piece No.	Description
1	Housing	55-3	Welsh Plug
2	Declutch Housing	56-1	Declutch Housing Gasket
3	Housing Cover	56-5	Grease Fitting
4	Worm Shaft End Cap	56-8	Hallowell Collar (3/4" Bore)
5	Handwheel 30°	56-13	Tripper Bolt
8	Torque Drive Sleeve	58	Tripper Spring
9	Handwheel Gear	70	Hinge
11	Declutch Lever	73	Bearing
13	Worm Gear	76	G.L. Threaded Collar
16-1	Bearing Cartridge Cap	77	Drive Shaft (Solid)
16-2	Thrust Washer	78	Gear Clutch Spacer
16-3	Belleville Spring	79	Bearing Adapter
16-5	Torque Limit Switch	80-1	Bearing Locknut
16-8	Bearing Cartridge Stem	81-1	Bearing Locknut
16-10	Nut-Cartridge Stem	81-2	Socket Head Setscrew
17	Hollow Drive Shaft	82-3	Flexible Jaw Clutch Sleeve
18	Handwheel Shaft and Pinion	82-4	Flexible Jaw Clutch Collar
19-1	Declutch Shaft	82-5	Nylon Insert
19-2	Declutch Arm	82-6	Internal Spacer
19-3	Declutch Lever Drum	83	Handwheel Clutch
19-7	Roll Pin	84	Gear Mounting Bracket
22	Motor Adapter	85	Bushing-Handwheel Gear
30-1	Worm	87	Splined Insert
30-2	Worm Bushing	88	Handwheel Washer
31-1	Motor Pinion	89	Handwheel Gear Spacer
31-2	Motor Drive Intermediate Gear	90	Stop Stud
32-1	Intermediate Pinion and Shaft	91	Declutch Shaft Washer
32-2	Drive Shaft Gear	92	Declutch Shaft Spacer
33	Sliding Gear Clutch	93	Declutch Lever Stop
34-A	Clutch Tripper #1	94	Torsion Spring
34-B	Clutch Tripper #2	95	Declutch Cap
40	Thrust Bearings	101	Bearing Spacer
42-1	Clutch Fork	102	Gear Insert
44-1	Bearing Lock Nut	103	Split Ring
46	Clutch Compression Spring	104	Retaining Ring
49	Spring Washer	105	Motor Gasket
52-1,-6,-7,-8,-9	Bearing	125	Thrust Adapter (Optional)
53-8	Spirolox Ring	127	Stem Nut
53-9	Spirolox Ring	128	Thrust Bearing Cartridge
54-2	WS End Cap Gasket	130	D.S. Locknut
54-3	Quad Ring	131	Drive Sleeve Thrust Bearing
54-5	O-Ring – Limit Switch Cover	140	Drive Sleeve Bushing
54-6	Oil Seal	162	Motor Adapter
54-7	Housing Cover Gasket	182	Handwheel Spinner Handle
54-8	Oil Seal	200-1	Limit Switch Compartment Cover
54-10	Declutch Cap Gasket	301	Torque Switch
54-11	Declutch Cover Gasket	305	Geared Limit Switch

9

Troubleshooting

Problem	Check
Geared limit switch fails to stop valve travel.	<ul style="list-style-type: none"> A. Control wiring and motor reversing contactor. B. Geared limit switch setting. C. Setting rod to see that it has been backed off after each side of the switch has been set. D. Remove limit switch and inspect for damaged or broken gear teeth.
Unable to operate actuator by motor.	<ul style="list-style-type: none"> A. Motor power and control circuits for supply and continuity. B. Supply voltage with vs. motor and controller nameplate rating. If O.K., then check motor amperage load. C. For stalled motor. Shut off power and operate actuator by handwheel to move the valve.
Excessive handwheel effort.	<ul style="list-style-type: none"> A. Lubrication method and valve stem for damage. B. To see if the valve packing gland is too tight. C. To see if the valve is improperly lubricated. D. To see if the stem nut is too tight on valve stem. E. For faulty or damaged valve or parts.

This page is intentionally blank.

10

How to Order Parts

To order parts or obtain further information about your Limitorque L120 valve actuators, contact your local Limitorque distributor, sales office, or:

Limitorque
5114 Woodall Road
P.O. Box 11318
Lynchburg, VA 24506-1318

Phone (434) 528-4400
Fax (434) 845-9736

To find the nearest Limitorque distributor or sales office near you, go to www.limitorque.com

All inquiries or orders must be accompanied by the following information:

1. Actuator Size
2. Order Number
3. Serial Number

This information can be found on the Limitorque nameplate affixed to the actuator.

This page is intentionally blank.

11

Regulatory Information

Declaration of Conformity

Application of Council Directive(s)

89/336/EEC; EMC Directive

98/37/EEC; Machinery Directive

Standard(s) to which Conformity is Declared

Machinery; EN 60204 EMC

- Emissions; EN 50081-1and2, EN 55011, CFR 47
- Immunity; EN 50082-1and2, IEC 801-3 and IEC 801-6 ESD; IEC 801-2
- EFT/Bursts; IEC 801-4
- Surge Immunity; IEC 801-5, ANSI/IEEE C62.41 Mains (power)
- Harmonics; MIL-STD-462, Method CS01 and CS02

Manufacturer's Name

Limatorque

Manufacturer's Address

5114 Woodall Road
Lynchburg, VA 24502

Importer's Name

Limatorque International

Importer's Address

Trinity House
Kennet Side
Newbury, Berkshire, RG15 5EH
England

Type and Description of Equipment

Valve Actuators

Model Number

L120 Series

Note

Tested with Limatorque products only

I, the undersigned, hereby declare that the equipment specified above conforms to the above Directive(s) and Standard(s).

List as follows:



(Signature)

Richard E. Fisher

(Full Name)

International Director

(Title)

Newbury, England

Place

January 1, 1999

Date

Australian Distributor for Limitorque

Acrodyne Pty Ltd
14/11 Havelock Road
Bayswater, Victoria 3153
Australia
Phone 03-8727-7800
Fax 03-9729-8699