

▲ PEAKTRONICS

The Peaktronics DMC-100 DC Motor Controllers are used for proportional positioning of actuators that use either DC motors or DC solenoids. The wide operating range of the DMC-100 (10 to 30 VDC and loads up to 15A locked rotor) allows operation in a variety of applications. An external command signal of 0-5V, 0-10V, 1-5V, or 4-20mA can be used to compare to a feedback signal from a potentiometer. The MOTOR 1 (*open*) or MOTOR 2 (*close*) output will energize, which powers the actuator motor or solenoids, until the feedback signal matches the command signal, at which time the controller's motor output is turned off and the actuator stops.

The unit has on-board LED indicators that show which direction the DMC-100 is attempting to move the actuator. The red LED comes on when the unit is attempting to move the actuator toward *open*. Conversely, the green LED comes on when the unit is attempting to move toward *closed*.

With a loss of command signal in the 1-5V or the 4-20mA input range, the unit offers three useful options: fail in place, the MOTOR 1 output on, or the MOTOR 2 output on. All input and output options are easily field configurable with jumper plugs. The only other adjustments consist of Deadband and non-interactive Zero and Span trimmers, which allows for easy field calibration.

The DMC-100B, DMC-100C, DMC-100D, and DMC-100E offer a current trip feature; this provides an indirect torque sense that shuts off the motor outputs when the motor current exceeds the trip setting. The DMC-100B and DMC-100C have a trip setting that can be adjusted for a range of 0.2A to 5A, while the DMC-100D and DMC-100E provide a trip range of 2A to 15A. These units also

DMC-100

DC Motor Controllers

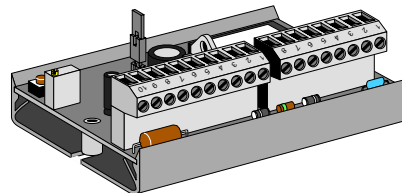

DMC-100
DMC-100B
DMC-100D

DMC-100A
DMC-100C
DMC-100E

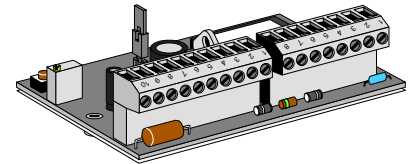

have a yellow LED trip indicator and a set of form-C contacts that can be used to power external alarms or lights.

The DMC-100, DMC-100B, and DMC-100D are mounted on Snaptrack®. Subsequently, the DMC-100A, DMC-100C, and DMC-100E are available with standoff mounts only (insulating sheet is included) which allows the units to be mounted directly to the actuator housing or bracket. All the units include an on-board fuse, and two removable screw terminal strips (for easy servicing).

Snaptrack® is a registered trademark of Augat/RDI.

ADDITIONAL FEATURES

- Dynamic braking eliminates need of mechanical brake to avoid motor coasting.
- Low standby current (20mA typical) when actuator is not in operation.
- Multiple units are easily connected in parallel to a common command signal.
- Limit switch inputs referenced to ground allows optional limit indicators with form-C limit switches.

OUTLINE

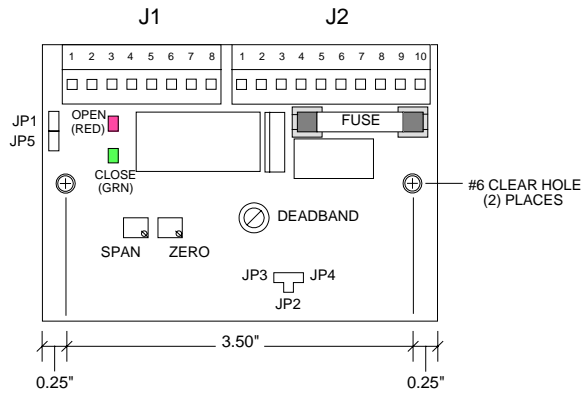

DMC-100 0-15A

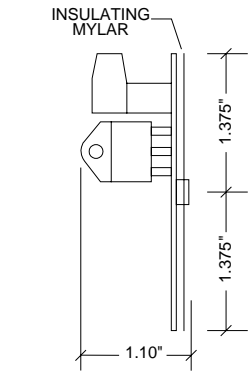
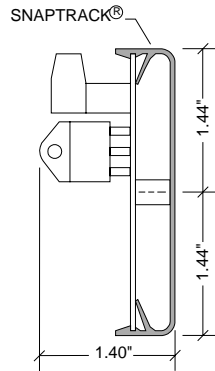

DMC-100A 0-15A

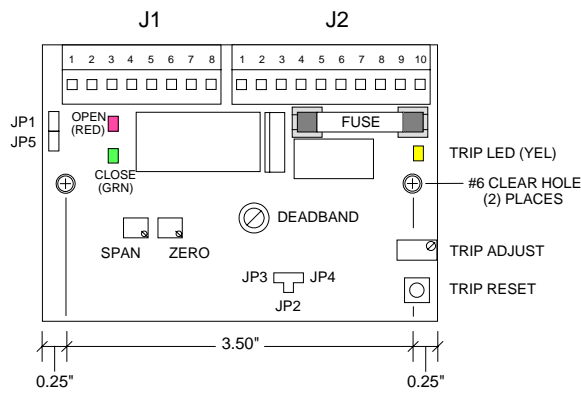

DMC-100B 0.2-5A
DMC-100D 2-15A

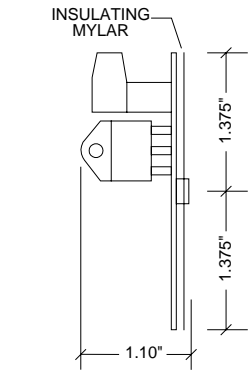
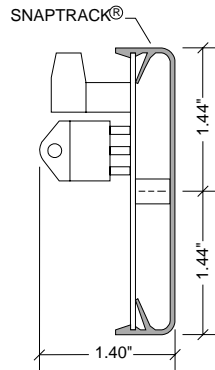

DMC-100C 0.2-5A
DMC-100E 2-15A

ELECTRICAL CONNECTIONS

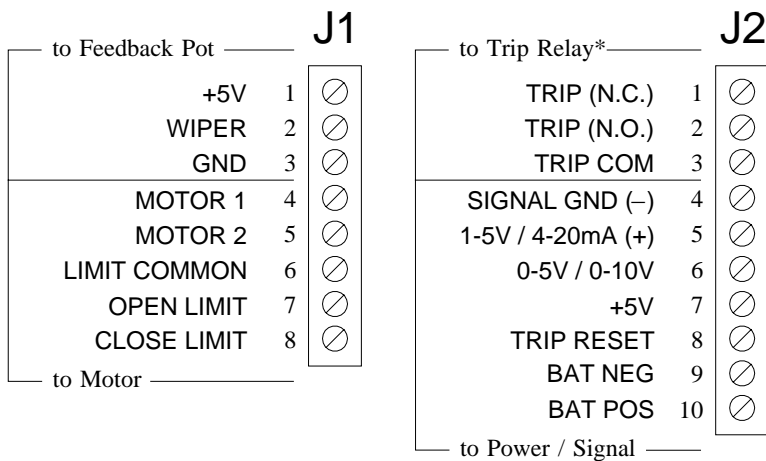

* DMC-100B, DMC-100C, DMC-100D, and DMC-100E only.

| INPUT SIGNAL | | |
|--------------------|-------------|---------|
| INPUT SIGNAL RANGE | JUMPER PLUG | |
| | JP1 | JP5 |
| 0-10V | install | remove |
| 1-5V | remove | install |
| 0-5V, 4-20mA | install | install |

| LOSS OF INPUT SIGNAL | |
|----------------------|-------------|
| OUTPUT STATE | JUMPER PLUG |
| BOTH OFF | JP2 |
| OPEN ON | JP3 |
| CLOSE ON | JP4 |

NOTE: Do not install JP2, JP3, or JP4 when using the 0-5V or 0-10V input signal range.

BLOCK DIAGRAM

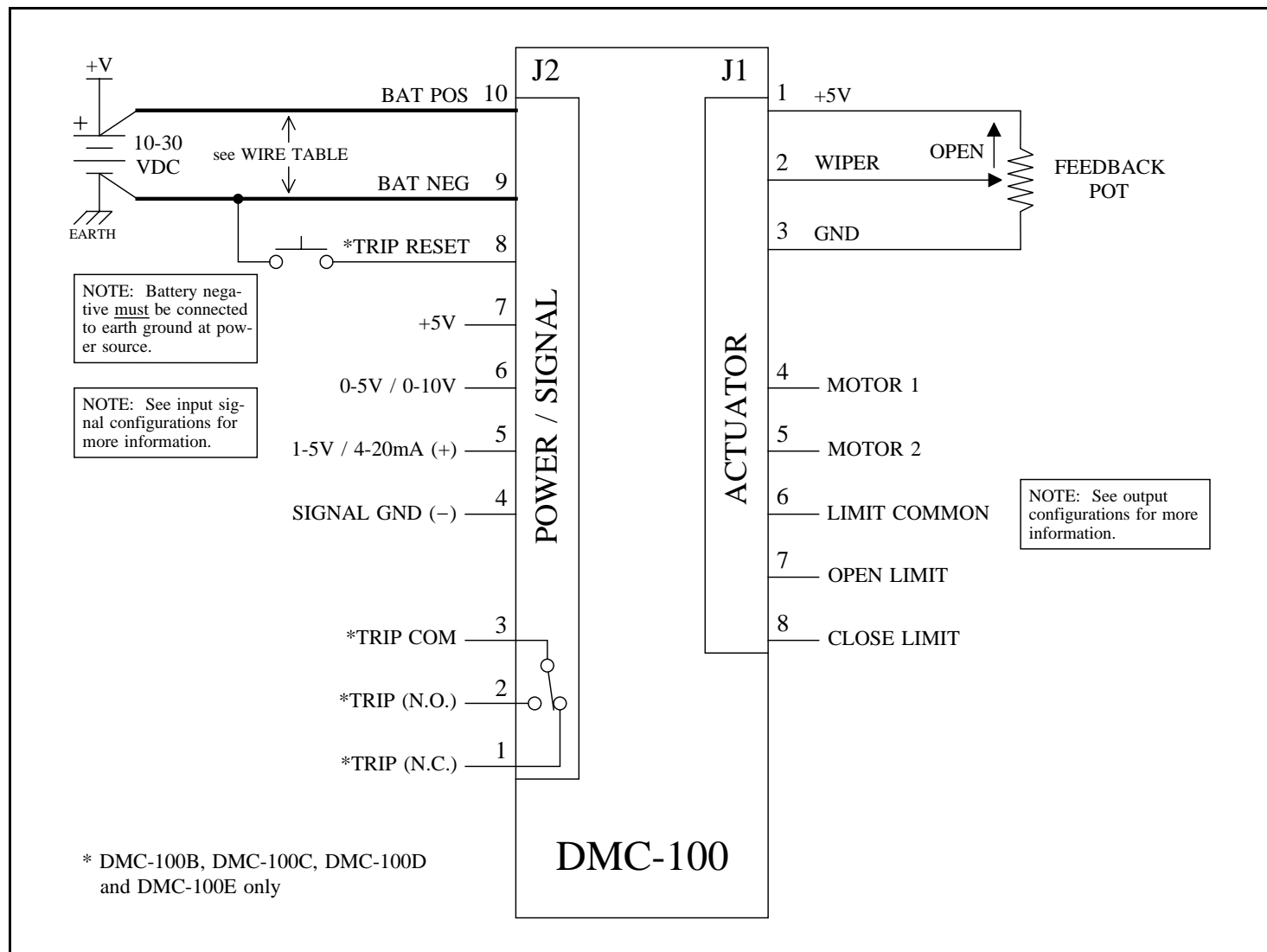

DESCRIPTION

The DMC-100 DC Motor Controllers come in various configurations to accommodate many applications. Basically three parameters should be considered in selecting the appropriate model: need for trip output, motor or solenoid current, and package configuration (see Outline information).

If the trip output is not required, the DMC-100 or DMC-100A should be used; each is capable of 15A locked rotor. When the trip output is required, the DMC-100B or DMC-100C can be used for motors up to 5A, and for up to 15A, the DMC-100D or DMC-100E should be used.

The DMC-100, DMC-100B, and DMC-100D come mounted on snaptrack. The DMC-100A, DMC-100C, and

DMC-100E come with standoff mounts for direct mounting to a bracket. An insulating sheet (included with the unit) must be used between the bracket and the unit. NOTE: these units are designed to be mounted in an appropriate enclosure; power should be disconnected prior to any wiring.

POWER / SIGNAL (J2)

The positive terminal of the DC power source is connected to pin 10 while the negative terminal connects to pin 9 (see Block Diagram). Transferring DC power can be

inefficient, therefore care should be taken to use appropriate wire sizes. The size wire required depends on the locked rotor motor current and the length of wire to be used. See the Wire Table for more information.

An appropriate command signal, either 0-5V, 0-10V, 1-5V, or 4-20mA, should be connected to pin 5 or 6 (as shown in the Block Diagram) while using pin 4 as the return *signal ground*. See Wiring Diagrams, Input Configurations, for wiring details. The DMC-100 must be configured for the type of command signal that is to be used - jumper plugs JP1 and JP5 are used for this; refer to the Outline drawing for proper installation of JP1 and JP5.

Pin 7 of J2 provides an auxiliary +5V output which can be used to connect a command potentiometer. By connecting one end of a potentiometer to pin 7, the other end to pin 4, and the wiper to pin 6, a local control knob can be implemented.

For units that have a trip output, pins 1, 2, and 3 provide a form-C contact arrangement with pin 3 as the common terminal. During normal operation, pin 1 is normally closed and pin 2 is normally open. Upon detecting a motor current above the trip setting, pin 2 will be closed while pin 1 is opened, and the on-board yellow LED will be turned on to indicate the tripped condition. The unit remains in the tripped condition until it is reset by either 1) pressing the on-board *trip reset* switch, 2) connecting pin 8 of J2 to pin 9 of J2 with a remote switch (see below), or 3) reversing the actuator direction using the command signal. Pins 1, 2, and 3 on the DMC-100 and DMC-100A (non-trip units) are not used and have no internal connections.

For units that have a trip output, Pin 8 of J2 provides an input for an optional remote *trip reset* switch (see Block Diagram). The remote switch is internally connected in parallel with the on-board reset switch; that is, both reset switches can be used. Pin 8 on the DMC-100 and DMC-100A (non-trip units) is not used and has no internal connection.

ACTUATOR (J1)

The actuator and feedback potentiometer are connected to J1. Pins 4 and 5 should be connected to a DC motor so that the actuator moves toward the *open* position with pin 4 being positive. Conversely, the actuator should move toward the *closed* position when pin 5 is positive. When powering solenoids, connect pin 4 to the solenoid that moves the actuator toward *open*, while pin 5 is connected to the solenoid that moves the actuator toward *closed*.

Internally, the DMC-100 connects pin 4 to BAT POS (J2-10) and pin 5 to BAT NEG (J2-9) when attempting to move the actuator toward the *open* position. The opposite occurs when the DMC-100 attempts to move the

actuator toward the *closed* position. Since pins 4 and 5 are alternately connected to BAT NEG (J2-9) and BAT POS (J2-10), care should be taken not to connect these pins to any other terminals.

The DMC-100 provides a dynamic braking feature that eliminates the need for a separate brake. When the DMC-100 turns off the motor outputs, pins 4 and 5 are internally connected to the BAT NEG pin (J2-9); this has the effect of shorting the motor leads together, thus braking the motor motion. This condition also holds true when power is removed from the DMC-100. In some applications, a brake is required for mechanical reasons, such as avoiding back driving the motor; the DMC-100 is suitable for powering most brakes, however, consult the actuator manufacturer for more information.

Many actuators include limit switches that are used to turn off the motor when the extreme ends of travel have been reached. Limit switches should be wired to pins 6, 7, and 8 (see Wiring Diagrams, Output Configurations). If limit switches are not used, pins 7 and 8 must be connected to pin 6 (note, if pins 7 and 8 are not connected to pin 6, the DMC-100 will not be able to control the motor outputs).

The feedback potentiometer wiper must be connected to pin 2 of J1. One end of the potentiometer is connected to pin 1, and the other is connected to pin 3. The potentiometer should be connected so that when the actuator moves towards the *open* position, the potentiometer's resistance between pins 2 and 3 will increase. This can also be measured as a voltage - the voltage between pins 2 and 3 should increase when the actuator moves towards the *open* position. If the potentiometer is wired incorrectly, the typical response of the unit will be to run the actuator to the full open or closed position (the appropriate output indicator will remain on) regardless of the command signal input.

The feedback potentiometer should be mounted to provide a proper feedback signal through the entire range between the *open* and *closed* positions. For best results, position the actuator to the midway point between the *open* and *closed* positions; then adjust the feedback potentiometer for approximately 2.5VDC (or 1/2 of the potentiometer's resistance) between pins 2 and 3 of J1.

Since the feedback potentiometer is crucial for proper operation of the DMC-100, the following items should be carefully observed:

- 1 - Potentiometer resistance should be a value from 1K to 10K ohms.
- 2 - The potentiometer should be a linear taper type.
- 3 - The potentiometer must be properly wired to provide the correct feedback signal.

- 4 - The potentiometer must be properly and securely mounted in order to provide a reliable feedback signal.

INDICATORS

The DMC-100 has on-board LED indicators that identify when one of the motor outputs is turned on. When the MOTOR 1 output is turned on, the red LED will turn on to indicate that the unit is trying to power the actuator toward *open*. When the MOTOR 2 output is turned on the green LED will turn on to indicate that the unit is trying to power the actuator toward *closed*. See the Outline drawing for location of the LED's.

Many actuators are equipped with limit switches at the *open* and *closed* positions which are intended to disconnect power to the motor to prevent mechanical damage. For this reason, it is possible that the DMC-100 will indicate that one of the motor outputs is turned on when the actuator is not in motion.

Units that have a trip output also have an on-board trip indicator LED (yellow). Upon detecting a motor current above the trip setting the trip indicator will turn on. The indicator will remain on until the unit is reset (see Power/Signal (J2)).

LOSS OF INPUT SIGNAL

When the 1-5V or 4-20mA type command signal is used, the DMC-100 can detect that the input signal has been disconnected. The unit can be configured to respond to the loss of command signal in one of three ways: turn both outputs off (leaving the actuator in its last position at the time signal was lost), turn on the MOTOR 1 output (to move the actuator to the full *open* position), or turn on the MOTOR 2 output (to move the actuator to the full *closed* position). To select the desired response to a loss of input signal, install jumper plug JP2, JP3, or JP4 as shown in the Outline information. NOTE: Power should be disconnected when installing or removing these jumpers.

When using this feature, certain precautions should be observed. For applications using the 0-5V or 0-10V input signal type, the unit **cannot** detect a loss of signal; **do not** install jumper plugs JP2, JP3, and JP4 for these applications. When JP3 or JP4 are installed, the unit will turn on one of the motor outputs when the input signal is lost; if the actuator does not use limit switches, these selections should not be used.

TRIP SETTING

For units with a trip output, adjusting the "Trip Adjust" (see Outline drawing for location) clockwise will allow higher motor currents before tripping. Starting with the "Trip Adjust" set fully clockwise, the trip limit can be set by applying the maximum normal load to the actuator, and then adjust the "Trip Adjust" counterclockwise until the unit trips.

CALIBRATION

The non-interactive zero and span adjustments of the DMC-100 allow for easy calibration once the unit is installed. After insuring that the feedback potentiometer and motor outputs are wired to provide a proper feedback signal, as described under "ACTUATOR (J1)", follow these steps to calibrate the unit (see Outline drawing for the location of the adjustments):

- 1 - Apply DC power to the unit, and set the command input signal to minimum:

0V for 0-5V input type
0V for 0-10V input type
1V for 1-5V input type
4mA for 4-20mA input type

- 2 - Adjust the "Zero" adjustment so that the actuator moves to the desired *closed* position. If the desired position cannot be achieved, check that the feedback potentiometer provides a feedback signal as described under "ACTUATOR (J1)"; also, check the position of the limit switches.
- 3 - If the actuator is hunting for position, turn the "Deadband" adjustment clockwise until hunting stops. If the actuator is not hunting for position, turn the "Deadband" adjustment counterclockwise until the actuator begins to hunt; then turn the "Deadband" adjustment slightly clockwise until hunting stops.

WARNING! Actuator failure may occur if the "Deadband" adjustment is set to allow continuous hunting. This can cause excessive wear of motor bearings, geartrain, brake, and feedback potentiometer. Hunting can also cause the internal temperature of the actuator housing to rise to a level that exceeds the maximum rating of the DMC-100, 65°C.

- 4 - Set the command signal input to maximum:

5V for 0-5V input type
10V for 0-10V input type
5V for 1-5V input type
20mA for 4-20mA type

- 5 - Adjust the "Span" adjustment so that the actuator moves to the desired *open* position. If the desired position cannot be achieved, check the position of the limit switch.

NOTE: The "Zero" adjustment is an offset setting rather than an absolute setting. Should the "Zero" adjustment be changed, the "Span" adjustment should be checked for the desired *open* position. Setting of the "Span" adjustment has no effect on the "Zero" adjustment.

- 6 - To check proper operation and linearity, set the command signal to halfway:

2.5V for 0-5V input type
5V for 0-10V input type
3V for 1-5V input type
12mA for 4-20mA input type

Verify that the actuator's position is midway between the *open* and *closed* positions.

REVERSE ACTING CALIBRATION

When converting a direct acting actuator to a reverse acting actuator, three changes in wiring must be made:

- 1 - Reverse the feedback potentiometer wires connected to J1-1 and J1-3.
- 2 - Reverse the motor output wires connected to J1-4 and J1-5.
- 3 - Reverse the open and close limit switch wires connected to J1-7 and J1-8.

NOTE: DO NOT reverse the input signal polarity.

After the wiring changes have been made, refer to **CALIBRATION** for setting the zero and span adjustments.

SPECIFICATIONS

POWER REQUIREMENTS

Operating Voltage: 10 to 30 VDC
Operating Current (motor on): 87 mA typical
Operating Current (trip output on): 40 mA typical
Standby Current (motor off, trip off): 20 mA typical
Fuse Type: 8A, Bussmann ABC-8

COMMAND SIGNAL INPUT

Common Mode Voltage (all inputs): -13 to +30 VDC
0-5 VDC Input
 Input Impedance: 10K ohms
 External Command Potentiometer: 1K ohm
0-10 VDC Input
 Input Impedance: 20K ohms
1-5 VDC Input
 Input Impedance: 200K ohms
 Loss of Command Signal Threshold: $\leq 0.75V$

4-20 mA Input

Input Impedance: 250 ohms +/-1%

Loss of Command Signal Threshold: $\leq 3\text{mA}$

FEEDBACK SIGNAL INPUT

Input Voltage: 0 to 5 VDC

External Feedback Potentiometer: 1K ohm to 10K ohms

COMMAND POTENTIOMETER POWER (J2-7)

5 VDC @ 5mA maximum

DC MOTOR OUTPUTS

Maximum Load Current: 15A locked rotor for 20 seconds typical

CONTROL ADJUSTMENTS

Zero: adjustable throughout feedback signal range

Span: adjustable throughout command signal range

Deadband: linearly adjustable throughout signal range

MOTOR CURRENT TRIP

Trip Range (not available on DMC-100 and DMC-100A)

DMC-100B, DMC-100C: 0.2 to 5 A

DMC-100D, DMC-100E: 2 to 15 A

Trip Setting: adjustable throughout specified range

Trip Relay Output: form-C contacts (0.5A @ 117VAC or 1A @ 30VDC)

Trip Reset (local): switch located on unit

Trip Reset (external): connect Trip Reset Input (J2-8) to Bat Neg (J2-9) with dry contact or open collector (10VDC @ 5mA)

ENVIRONMENTAL

Operating Temperature Range: 0 °C to 60 °C

Storage Temperature Range: -40 °C to 85 °C

Relative Humidity Range: 0 to 90 % (noncondensing)

WIRING DIAGRAMS

Output Configurations

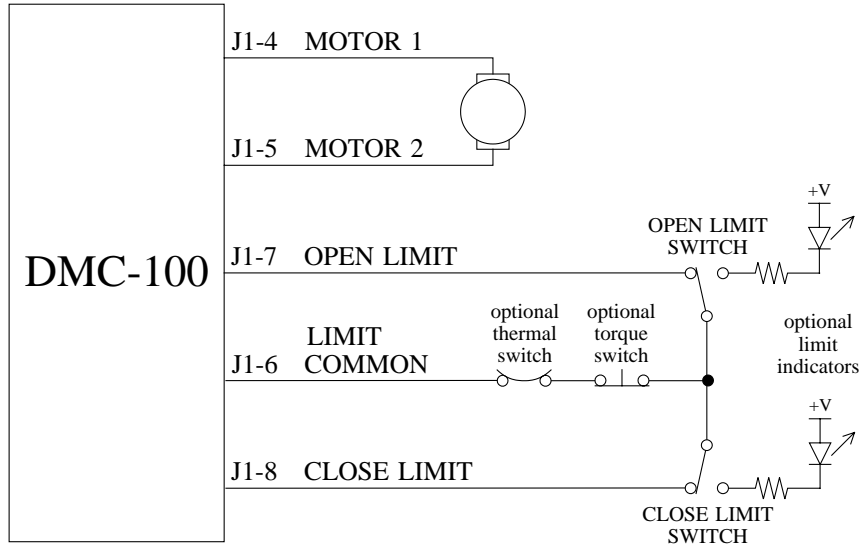

DC Motor Control Output

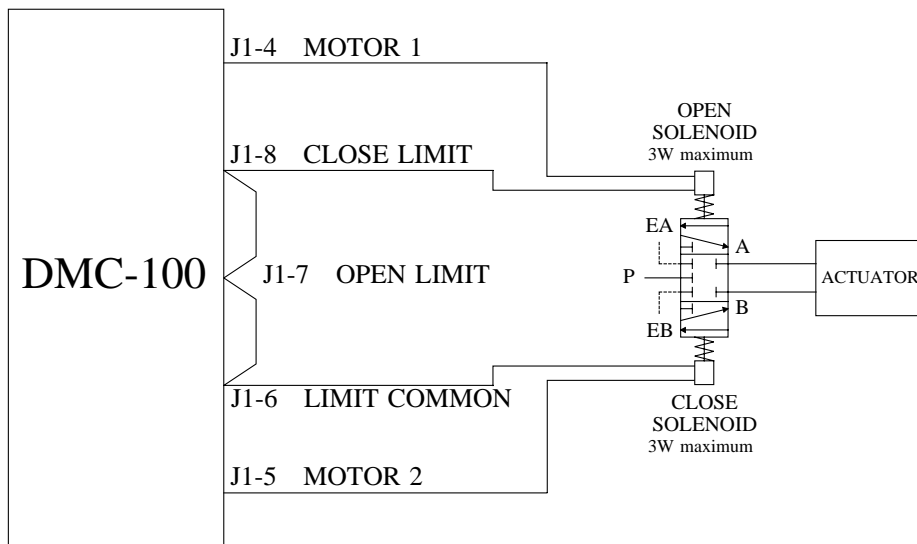

DC Solenoid Control Output

WIRING DIAGRAMS

Input Signal Configurations

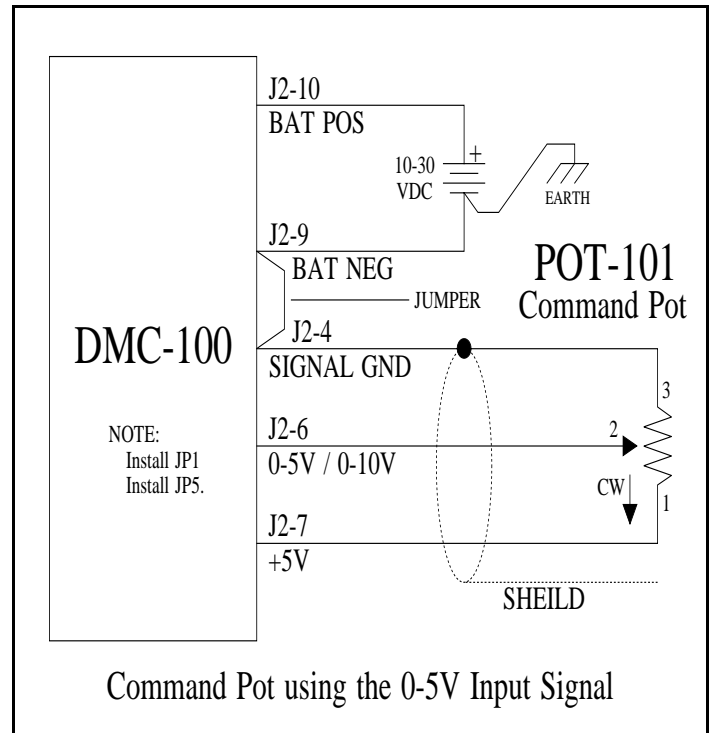
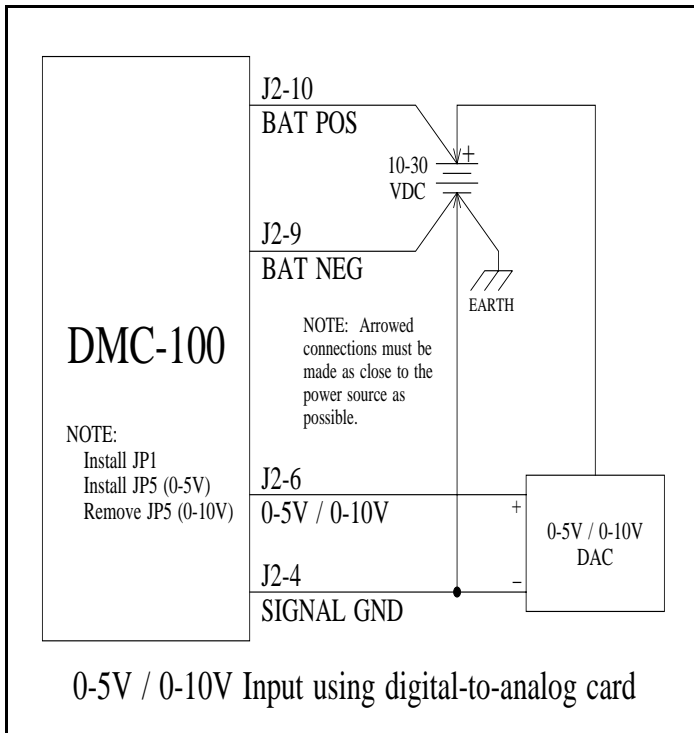
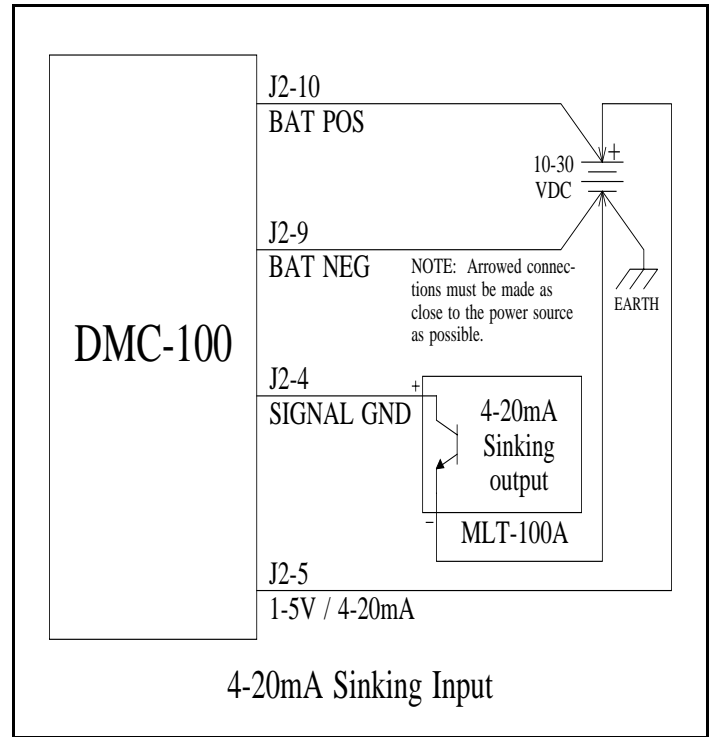
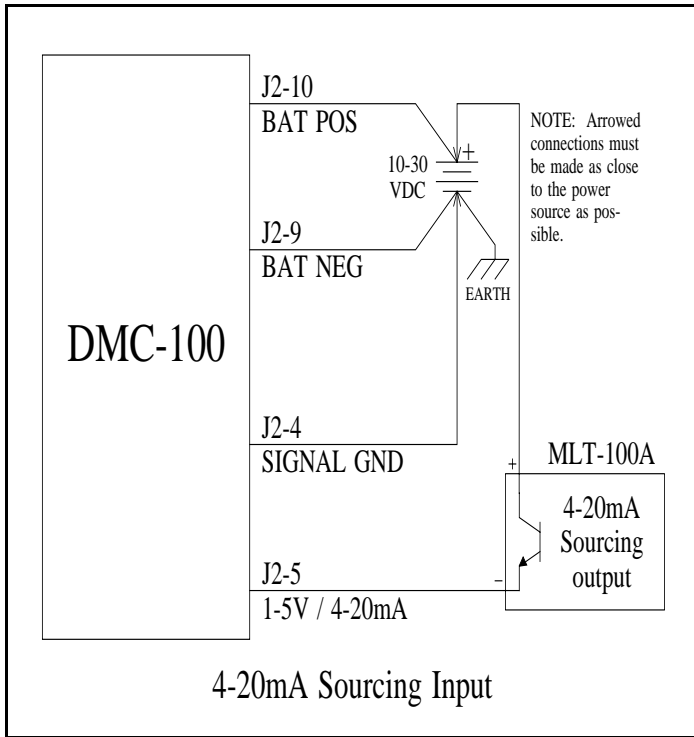

WIRING DIAGRAMS

Special Applications

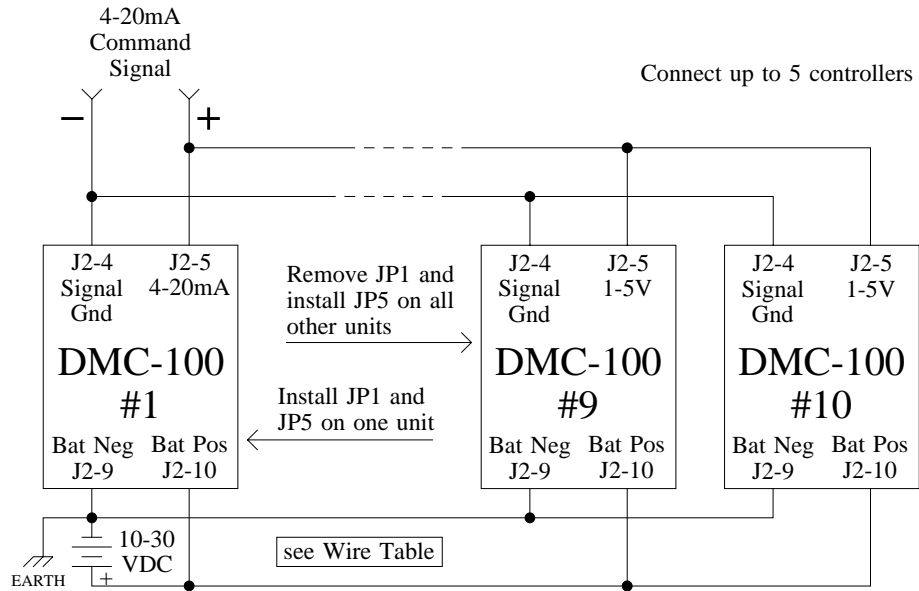

Controlling multiple units using a single 4-20mA signal

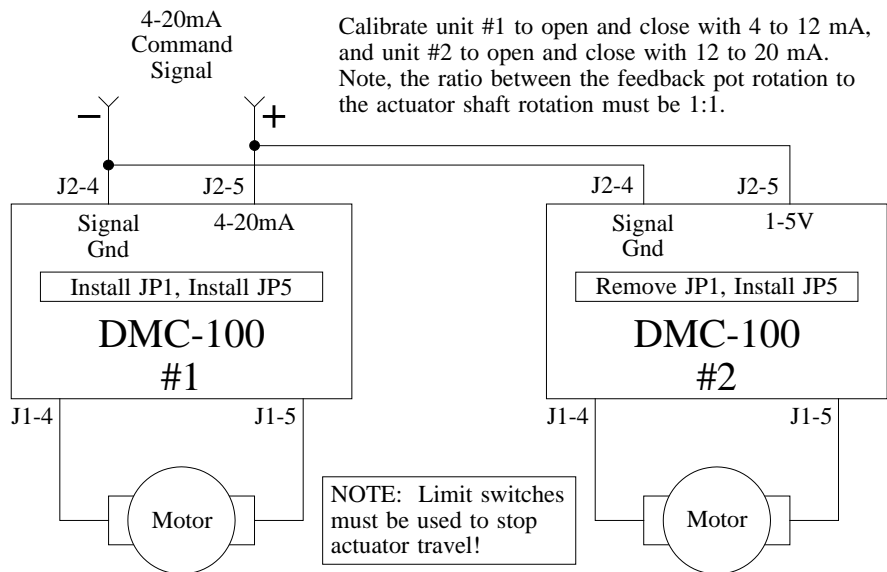

Split range control

WIRING DIAGRAMS

Special Applications

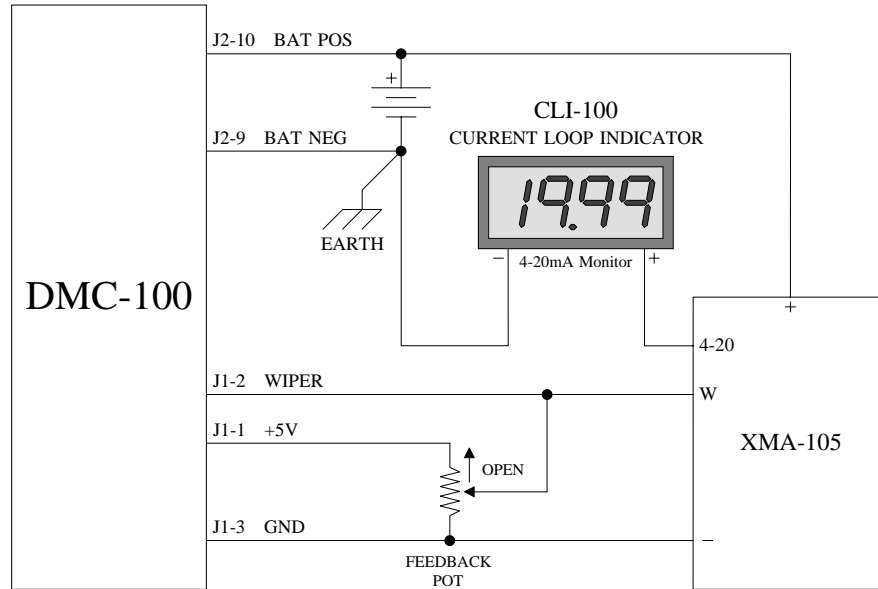

Connecting a Position Feedback Transmitter

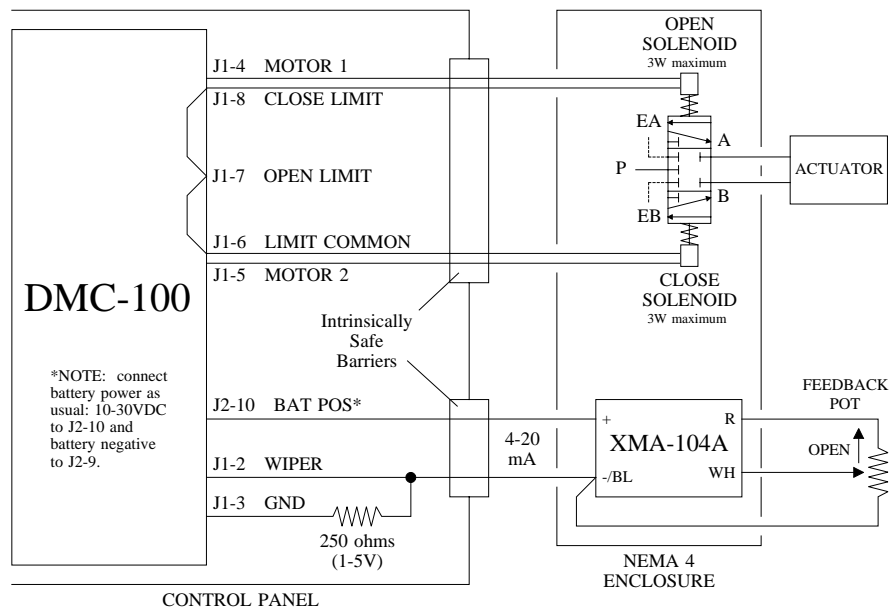

Intrinsically Safe Solenoid Controller

WIRE TABLE

The table below shows the maximum recommended distance (in linear feet) between the battery source and the DMC-100 unit. The maximum distance is limited by the wire size used and the locked rotor current of the motor. All signal wires on the DMC-100 should be connected with wires sizes ranging from 22 to 18 AWG.

| ft | Wire Size | | | | | | |
|-----------------------------|-----------|--------|--------|--------|------------------------|-----------------------|-----------------------|
| Locked Rotor Current (Amps) | 18 AWG | 16 AWG | 14 AWG | 12 AWG | 10 AWG (see Note 1) | 8 AWG (see Note 1) | 6 AWG (see Note 1) |
| 1 | 133 | 211 | 337 | 535 | 847 | 1353 | 2151 |
| 2 | 66 | 106 | 169 | 268 | 424 | 677 | 1076 |
| 3 | 44 | 70 | 112 | 178 | 282 | 451 | 717 |
| 4 | 33 | 53 | 84 | 134 | 212 | 338 | 538 |
| 5 | 27 | 42 | 67 | 107 | 169 | 271 | 430 |
| 6 | 22 | 35 | 56 | 89 | 141 | 226 | 359 |
| 7 | 19 | 30 | 48 | 76 | 121 | 193 | 307 |
| 8 | 17 | 26 | 42 | 67 | 106 | 169 | 269 |
| 9 | 15 | 23 | 37 | 59 | 94 | 150 | 239 |
| 10 | 13 | 21 | 34 | 54 | 85 | 135 | 215 |
| 11 | 12 | 19 | 31 | 49 | 77 | 123 | 196 |
| 12 | 11 | 18 | 28 | 45 | 71 | 113 | 179 |
| 13 | 10 | 16 | 26 | 41 | 65 | 104 | 165 |
| 14 | 10 | 15 | 24 | 38 | 61 | 97 | 154 |
| 15 | 9 | 14 | 22 | 36 | 56 | 90 | 143 |

NOTES

- 1) The DMC-100 terminal strip will not accept wire sizes larger than 12 AWG. Use a short run of 12 AWG from the DMC-100 to an auxiliary terminal block when larger wire is needed.
- 2) If the motor is located some distance from the DMC-100, add this length to the overall wire length; be sure to use an appropriate wire size to the motor.
- 3) When multiple actuators are powered by a common set of wires, use the sum of all the motor currents when determining wire size.