

# ▲ PEAKTRONICS

The Peaktronics AMC-100/AMC-101 AC Motor Controllers are used for proportional positioning of split phase AC actuator motors. An external command signal of 0-10V, 1-5V, or 4-20mA can be used to compare to a feedback signal from a potentiometer. The *open* or *closed* AC output will energize, which powers the actuator motor, until the feedback signal matches the command signal, at which time the controller's AC output is turned off and the actuator motor stops.

With a loss of command signal in the 1-5V or the 4-20mA input range, the AMC-100/AMC-101 offers three useful options: fail in place, the *open* output on, or the *closed* output on. All input and output options are easily field configurable with jumper plugs. The only other adjustments consist of Deadband and non-interactive Zero and Span trimmers, which allows for easy field calibration.

These controllers are available in versions for 117VAC  $\pm 10\%$ , 234VAC  $\pm 10\%$ , or 24VAC  $\pm 10\%$  power and give the user optical isolation between the input signal and the AC outputs. The unit includes a red LED indicator (for the *open* output), a green LED indicator (for the *closed* output), an on-board fuse, and two removable screw terminal strips (for easy servicing).

The AMC-100 (117VAC), AMC-100B (234 VAC), and AMC-100D(24VAC) are mounted on Snap-track® and deliver 2A at 60°C. Subsequently, the AMC-101 (117 VAC), AMC-101B (234VAC), and AMC-101D (24VAC) are mounted on an aluminum extrusion and can deliver 5A at 60°C. All six versions are available with standoff mounts only (insulating sheet is included) which allows the units to be mounted directly to the actuator housing or bracket. Note, the housing or bracket is required for heatsinking the AMC-101A, AMC-101C, and AMC-101E 5A units.

Snaptrack® is a registered trademark of Augat/RDI.

## AMC-100 AMC-101

### AC Motor Controllers

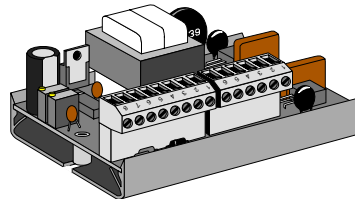

AMC-100  
AMC-100B  
AMC-100D

AMC-101  
AMC-101B  
AMC-101D

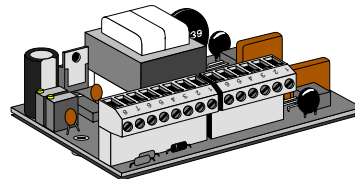
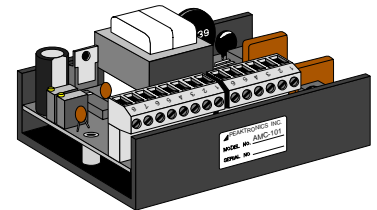

AMC-100A  
AMC-100C  
AMC-100E  
AMC-101A  
AMC-101C  
AMC-101E

## ADDITIONAL FEATURES

- Multiple units are easily connected in parallel to a common command signal.
- Built-in utility power supplies for powering a command pot, 4-20mA input or output transmitter, and the feedback potentiometer.
- No external motor resistors are required.

# OUTLINE

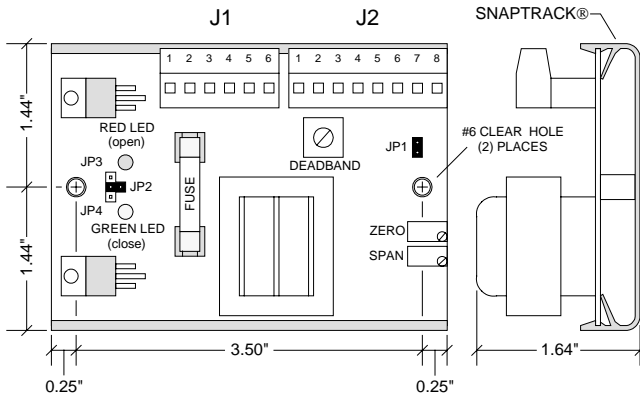

AMC-100 117VAC, 2A  
 AMC-100B 234VAC, 2A  
 AMC-100D 24VAC, 2A

## ELECTRICAL CONNECTIONS

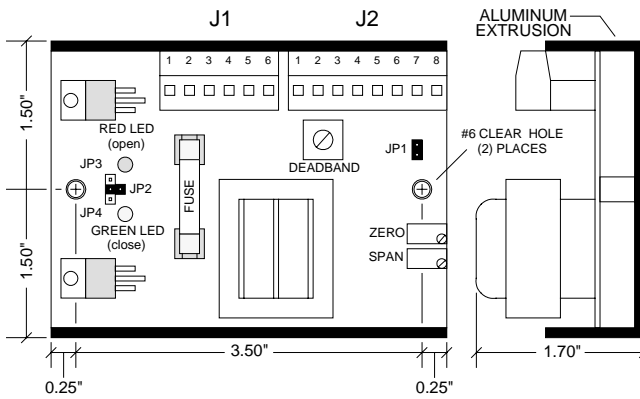
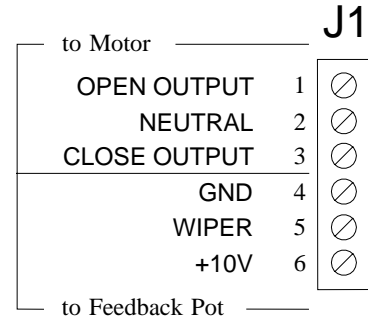

AMC-101 117VAC, 5A  
 AMC-101B 234VAC, 5A  
 AMC-101D 24VAC, 5A

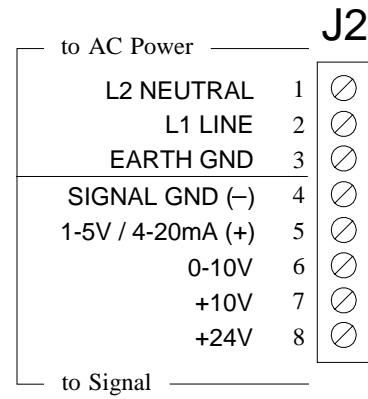

INPUT SIGNAL	
INPUT SIGNAL RANGE	JP1 JUMPER PLUG
0-10V	INSTALL
1-5V	REMOVE
4-20mA	INSTALL

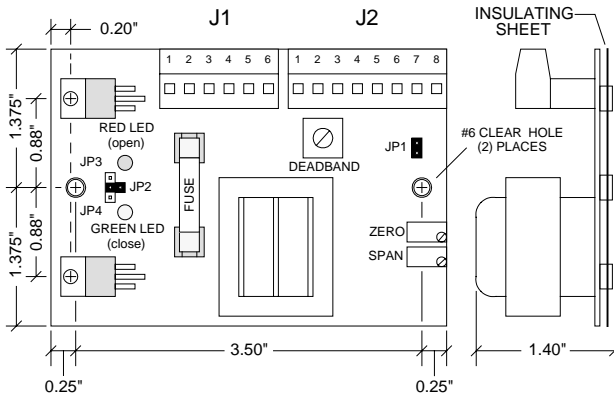

AMC-100A 117VAC, 2A      AMC-101A 117VAC, 5A  
 AMC-100C 234VAC, 2A    AMC-101C 234VAC, 5A  
 AMC-100E 24VAC, 2A      AMC-101E 24VAC, 5A

LOSS OF INPUT SIGNAL	
OUTPUT STATE	JUMPER PLUG
BOTH OFF	JP2
OPEN ON	JP3
CLOSE ON	JP4

NOTE: Do not install JP2, JP3, or JP4 when using the 0-10V input signal range. Power must be off when installing these jumpers.

## BLOCK DIAGRAM

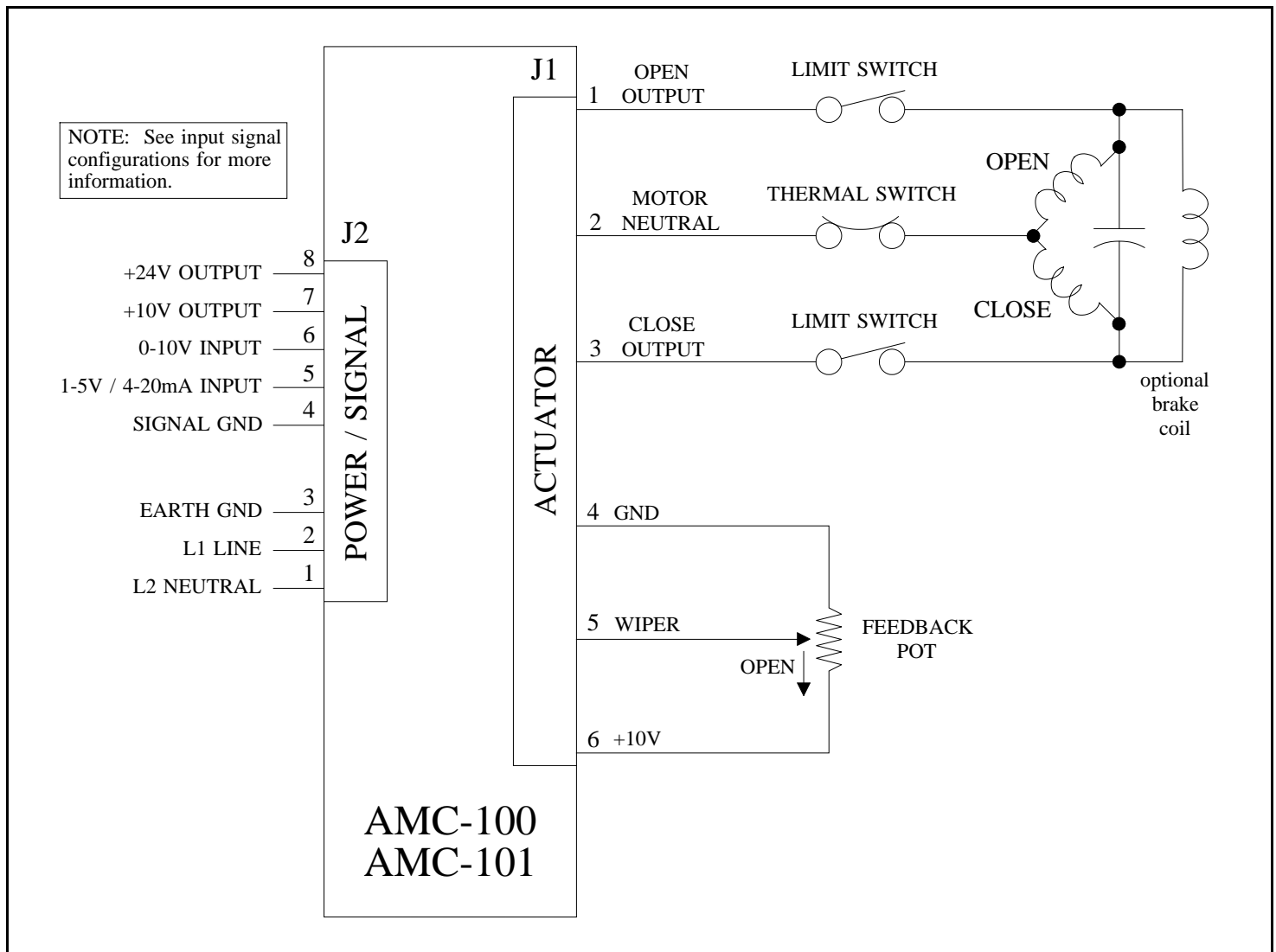

## DESCRIPTION

The AMC-100/AMC-101 AC Motor Controllers come in various configurations to accommodate many applications. Basically three parameters should be considered in selecting the appropriate model: motor current, operating voltage, and package configuration (see Outline information).

The AMC-100 controllers are rated for 2A motors and are available for either 117VAC, 234VAC, or 24VAC operation. The AMC-100, AMC-100B, and AMC-100D come mounted on snaptrack while the AMC-100A, AMC-100C, and AMC-100E have standoffs for direct mounting to a bracket (insulating sheet is included). The AMC-101 controllers are rated for 5A motors and also come in

117VAC, 234VAC, or 24VAC versions. The AMC-101, AMC-101B, and AMC-101D are packaged on an aluminum extrusion. The AMC-101A, AMC-101C, and AMC-101E come with standoff mounts - these units **require** screw mounting through all four standoffs to a suitable metal plate or bracket in order to provide sufficient heatsinking for the unit.

**CAUTION !** These units are intended to be mounted in an appropriate enclosure to avoid electrical shocks. High voltages are present on the outside of the unit when power is applied. AC power should be disconnected prior to any wiring of these units. A heater and thermostat should be used where condensation may occur.

## POWER / SIGNAL (J2)

Power is connected to pins 1, 2, and 3 as shown in the block diagram above. The fuse installed on the unit is rated for maximum output current that can be safely delivered by the AC outputs. Replacement fuses must not exceed these maximum ratings (2A for the AMC-100 controllers and 5A for the AMC-101 controllers) to prevent damage to the unit. Smaller fuse sizes can be used with smaller motors - consult the actuator manufacturer for appropriate fuse size and type.

An appropriate command signal, either 0-10V, 1-5V, or 4-20mA, should be connected to pin 5 or 6 (as shown in the Block Diagram) while using pin 4 as the return *signal ground*. The AMC-100/AMC-101 must be configured for the type of command signal that is to be used - jumper plug JP1 must be installed whenever a 4-20mA or 0-10V input is used (see Outline).

Pin 7 of J2 provides an auxiliary +10V output which can be used to connect a command potentiometer. By connecting one end of a potentiometer to pin 7, the other end to pin 4, and the wiper to pin 6, a local control knob can be implemented. Pin 8 provides an auxiliary +24VDC output which can be used to power an input or output 4-20mA transmitter.

## ACTUATOR (J1)

The actuator and feedback potentiometer are connected to J1 as shown in the block diagram. Pin 1 should be connected to the motor winding that moves the actuator toward the *open* position, and conversely, pin 3 is connected to the winding that moves the actuator toward the *closed* position. Pin 2 is the neutral or common wire to the motor windings. The AMC-100/AMC-101 is suitable for powering most dynamic brakes used with electric actuators; however, consult the actuator manufacturer for more information.

The feedback potentiometer wiper must be connected to pin 5 of J1. One end of the potentiometer is connected to pin 4, and the other is connected to pin 6. The potentiometer should be connected so that when the actuator moves towards the *open* position, the potentiometer's resistance between pins 4 and 5 will increase. This can also be measured as a voltage - the voltage between pins 4 and 5 should increase when the actuator moves towards the *open* position. If the potentiometer is wired incorrectly, the typical response of the unit will be to run the actuator to the full open or closed position (the appropriate output indicator will remain on) regardless of the command signal input.

The feedback potentiometer should be mounted to provide a proper feedback signal through the entire range between the *open* and *closed* positions. For best results,

position the actuator to the midway point between the *open* and *closed* positions; then adjust the feedback potentiometer for approximately 5VDC (or 1/2 of the potentiometer's resistance) between pins 4 and 5 of J1.

Since the feedback potentiometer is crucial for proper operation of the AMC-100/AMC-101, the following items should be carefully observed:

- 1 - Potentiometer resistance should be a value from 1K to 10K ohms.
- 2 - The potentiometer should be a linear taper type.
- 3 - The potentiometer must be properly wired to provide the correct feedback signal.
- 4 - The potentiometer must be properly and securely mounted in order to provide a reliable feedback signal.

## OUTPUT INDICATORS

The AMC-100/AMC-101 units have on-board indicators that identify when one of the motor outputs is turned on. When the open output is turned on, the red LED indicator will turn on, and when the close output is turned on the green LED indicator will turn on (see Outline).

Many actuators are equipped with limit switches at the *open* and *closed* positions which are intended to disconnect power to the motor to prevent mechanical damage. For this reason, it is possible that the AMC-100/AMC-101 will indicate that one of the motor outputs is turned on when the actuator is not in motion. However, it should be noted that when the indicator is on, power is applied to the motor output.

## LOSS OF INPUT SIGNAL

When the 1-5V or 4-20mA type command signal is used, the AMC-100/AMC-101 can detect that the input signal has been disconnected. The unit can be configured to respond to the loss of command signal in one of three ways: turn both outputs off (leaving the actuator in its last position at the time signal was lost), turn on the open output (to move the actuator to the full *open* position), or turn on the close output (to move the actuator to the full *closed* position). To select the desired response to a loss of input signal, install jumper plug JP2, JP3, or JP4 as shown in the Outline information. **CAUTION!** Power must be disconnected when installing or removing these jumpers - damage to the unit may occur if these jumpers are set with power on.

When using this feature, certain precautions should be observed. For applications using the 0-10V input signal type, the unit **cannot** detect a loss of signal; **do not** install jumper plugs JP2, JP3, and JP4 for these applications. When JP3 or JP4 are installed, the unit will turn on one of the motor outputs when the input signal is lost; if the actuator does not use limit switches, these selections should not be used.

## CALIBRATION

The non-interactive zero and span adjustments of the AMC-100/AMC-101 allow for easy calibration once the unit is installed. After insuring that the feedback potentiometer and motor outputs are wired to provide a proper feedback signal, as described under "ACTUATOR (J1)", follow these steps to calibrate the unit (see Outline for the location of the adjustments):

- 1 - Apply AC power to the unit, and set the command input signal to minimum:

0V for 0-10V input type  
1V for 1-5V input type  
4mA for 4-20mA input type

- 2 - Adjust the "Zero" adjustment so that the actuator moves to the desired *closed* position. If the desired position cannot be achieved, check that the feedback potentiometer provides a feedback signal as described under "ACTUATOR (J1)"; also, check the position of the limit switches.
- 3 - If the actuator is hunting for position, turn the "Deadband" adjustment clockwise until hunting stops. If the actuator is not hunting for position, turn the "Deadband" adjustment counterclockwise until the actuator begins to hunt; then turn the "Deadband" adjustment slightly clockwise until hunting stops.

**WARNING!** Actuator failure may occur if the "Deadband" adjustment is set to allow continuous hunting. This can cause excessive wear of motor bearings, geartrain, dynamic brake, and feedback potentiometer. Hunting can also cause the internal temperature of the actuator housing to rise to a level that exceeds the maximum rating of the AMC-100/AMC-101, 60°C.

- 4 - Set the command signal input to maximum:

10V for 0-10V input type  
5V for 1-5V input type  
20mA for 4-20mA type

- 5 - Adjust the "Span" adjustment so that the actuator moves to the desired *open* position. If the desired position cannot be achieved, check the position of the limit switch.

**NOTE:** The "Zero" adjustment is an offset setting rather than an absolute setting. Should the "Zero" adjustment be changed, the "Span" adjustment should be checked for the desired *open* position. Setting of the "Span" adjustment has no affect on the "Zero" adjustment.

- 6 - To check proper operation and linearity, set the command signal to halfway:

5V for 0-10V input type  
3V for 1-5V input type  
12mA for 4-20mA input type

Verify that the actuator's position is midway between the *open* and *closed* positions.

## REVERSE ACTING CALIBRATION

When converting a direct acting actuator to a reverse acting actuator, two changes in wiring must be made:

- 1 - Reverse the feedback potentiometer wires connected to J1-4 and J1-6.
- 2 - Reverse the motor output wires connected to J1-1 and J1-3.

**NOTE: DO NOT** reverse the input signal polarity. Also, make sure that both wiring changes are made - if only one is made, the actuator will run to either full *open* or full *closed*.

After the wiring changes have been made, refer to **CALIBRATION** for setting the zero and span adjustments.

## SPECIFICATIONS

### POWER REQUIREMENTS

AMC-100, AMC-100A, AMC-101, AMC-101A: 117VAC  $\pm$ 10%, 50/60 Hz  
AMC-100B, AMC-100C, AMC-101B, AMC-101C: 234VAC  $\pm$ 10%, 50/60 Hz  
AMC-100D, AMC-100E, AMC-101D, AMC-101E: 24VAC  $\pm$ 10%, 50/60 Hz  
3.6 VA typical (not including output load)  
Fuse Type:  
AMC-100x: 2A 3AG Slo-Blo  
AMC-101x: 5A 3AG Slo-Blo

### COMMAND SIGNAL INPUT

0-10 VDC Input  
Input Impedance: 11K ohms minimum  
External Command Potentiometer: 1K ohm  
1-5 VDC Input  
Input Impedance: 1M ohms minimum  
*Loss of Command Signal* Threshold:  $\leq$  0.75V  
4-20 mA Input  
Input Impedance: 250 ohms  $\pm$ 1%  
*Loss of Command Signal* Threshold:  $\leq$  3mA

### FEEDBACK SIGNAL INPUT

Input Voltage: 0 to 10 VDC  
External Feedback Potentiometer: 1K ohm to 10K ohms

### POWER SUPPLY OUTPUTS

Input or Output Transmitter Power (J2-8): 24VDC @ 20mA max  
Command Signal Potentiometer Power (J2-7): 10VDC @ 10mA max  
**NOTE:** *Do not* connect these outputs to other power supplies.

### AC MOTOR OUTPUTS

Off-state Leakage Current: <15mA  
Maximum Load Current @ 60°C:  
AMC-100x: 2A  
AMC-101x: 5A (when properly mounted)

### CONTROL ADJUSTMENTS

Zero: adjustable throughout feedback signal range  
Span: adjustable throughout command signal range  
Deadband: adjustable from 0.12% to 2.4% of span

### ENVIRONMENTAL

Operating Temperature Range: 0 °C to 60 °C  
Storage Temperature Range: -40 °C to 85 °C  
Relative Humidity Range: 0 to 90 % (noncondensing)

## WIRING DIAGRAMS

### Input Signal Configurations

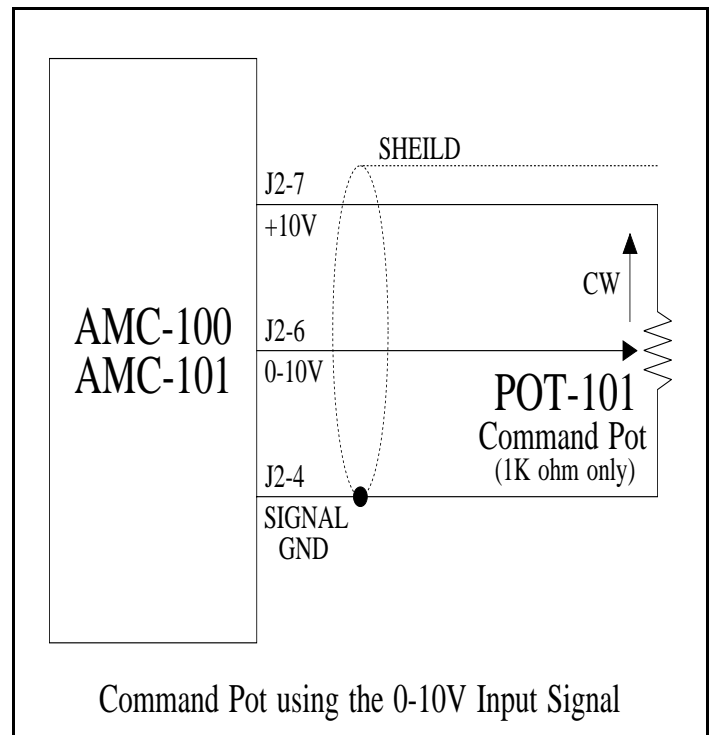
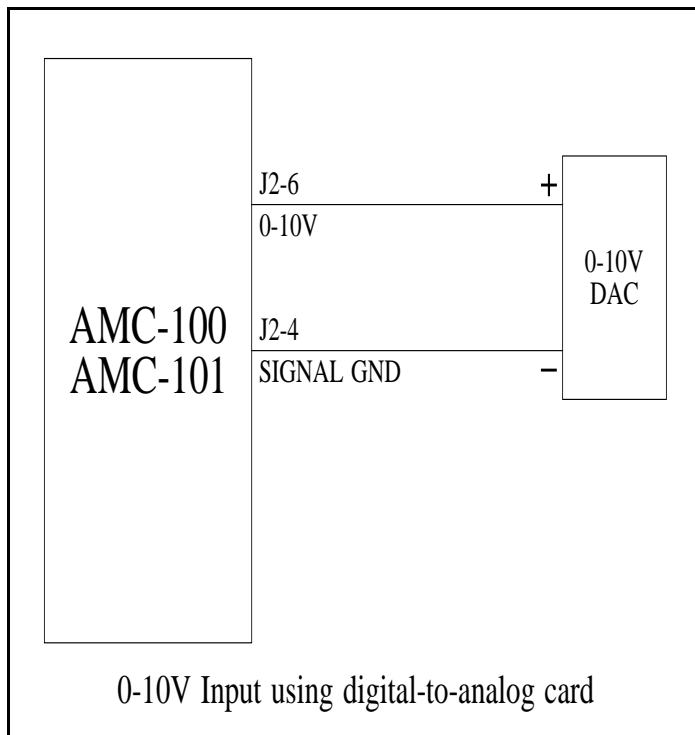
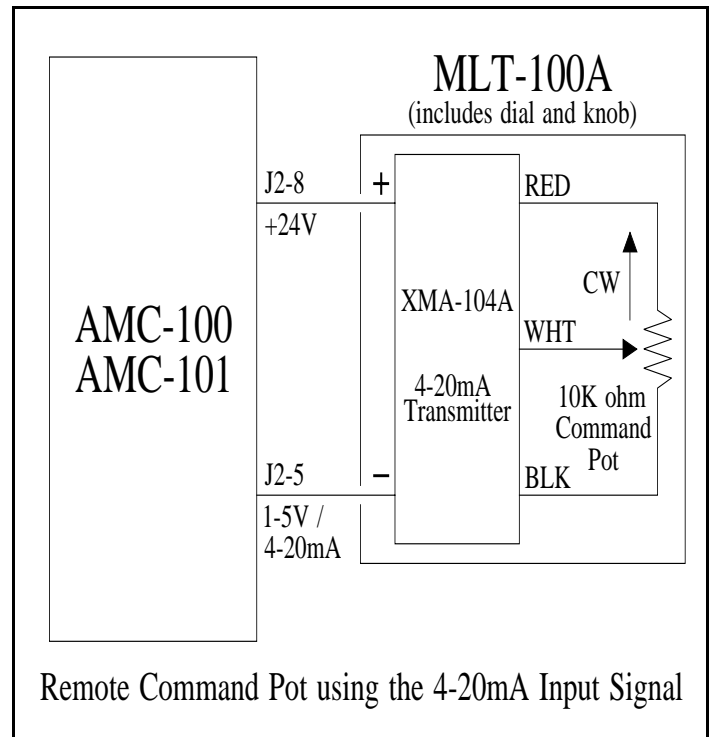
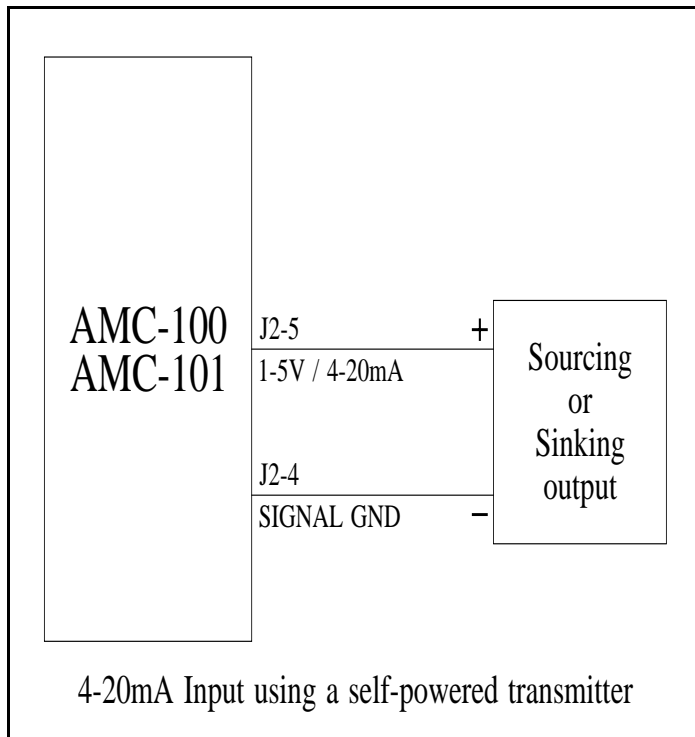

## WIRING DIAGRAMS

### Special Applications

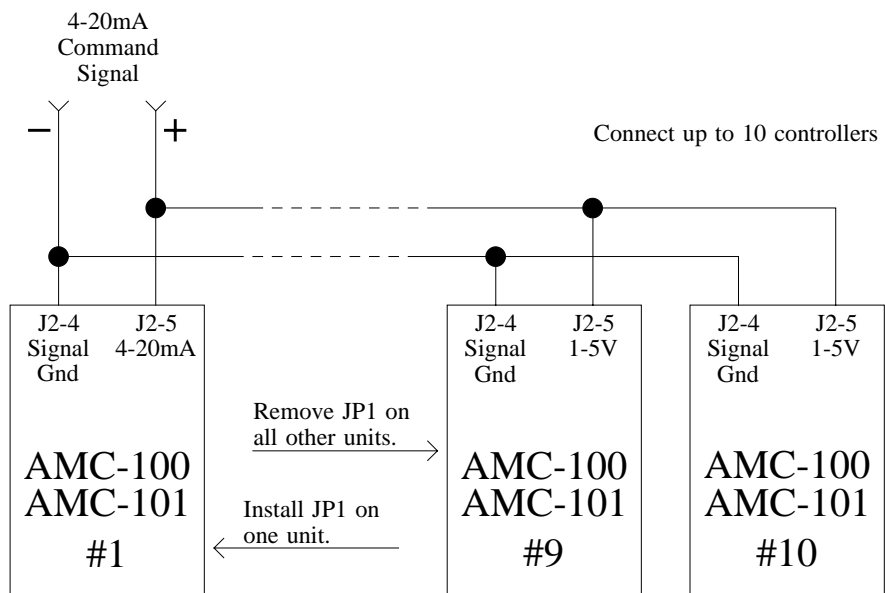

Controlling multiple units using a single 4-20mA signal

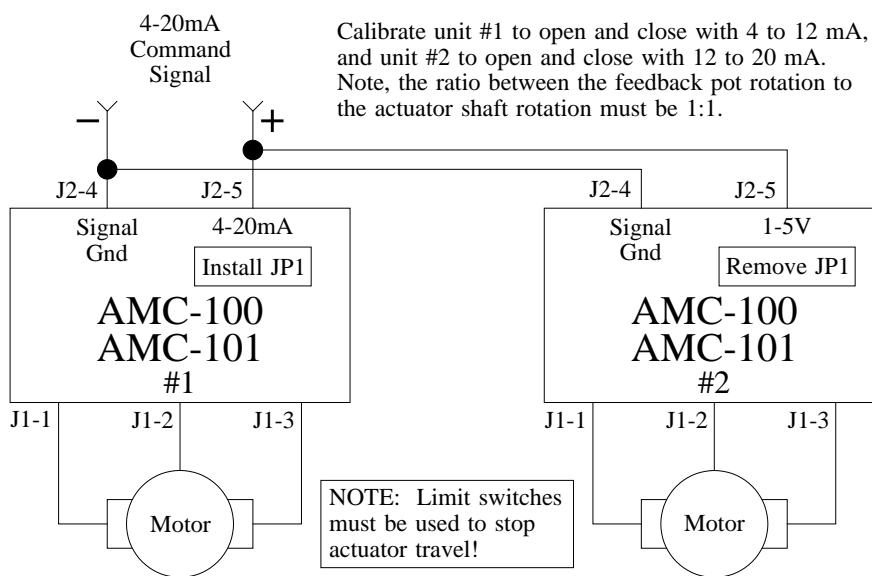

Split range control