

## Electro-Pneumatic Positioner

### YT-1300 Series

# USER'S MANUAL

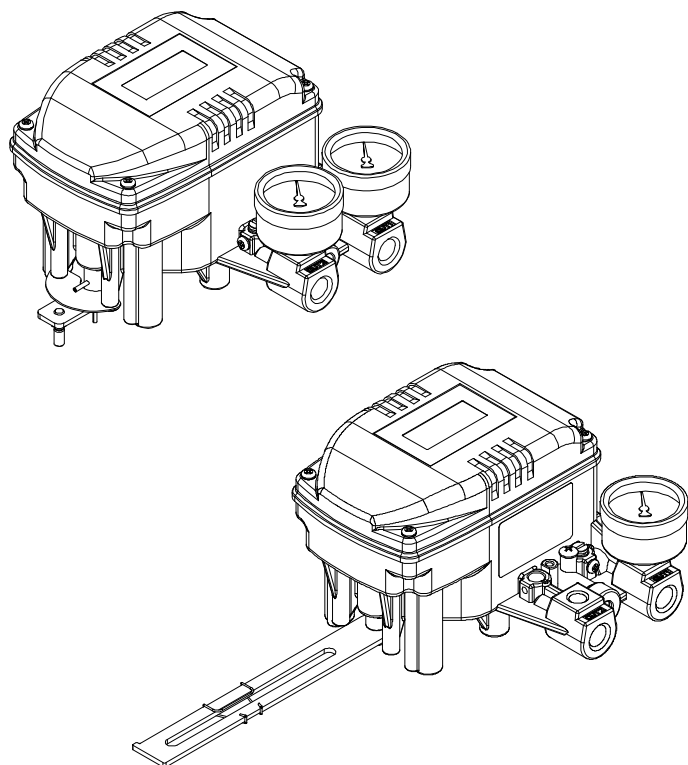

YTC

V.1.00

-Content (H/W)-	
Content	2
Manual description	4
Notes on safety and warranty	4
Product description	5
Features and functions	5
Nameplate description	6
Ordering number	7
Specifications	8
Structure	9
Installation	10
Notes	10
YT-1300L drawing	10
YT-1300R drawing	11
Tools for installation	12
YT-1300L installation	12
Example	12
Installing YT-1300L with bracket	13
YT-1300R installation	17
Example	17
Installing YT-1300R with bracket	18
Piping connection	21
Note	21
Conditions of supply pressure	22
Conditions of pipe	22
YT-1300 Piping connection with actuator	22
Single acting actuator	22
Double acting actuator	23
Power connection	24
Notes	24
Terminal connection of current input signal	25
Terminal connection of feedback signal	26
Terminal connection for limit switch	27
Terminal connection for ground	28
A/M Switch	29



## Product Description

YT-1300 Electro-positioner controls valve stroke accurately according to input signal of 4-20mA being input from controller. In addition, optionally high efficiency, high accuracy, high confident operator built in the performs position transmitter, limit switch at the same time.

### Features and functions

1. It endures severe vibration.
2. It is operated normally regardless of change of supply pressure during operation.
3. Calibration method is very simple.
4. It is easily equipped on small actuator because of its small size.
5. Air consumption is so small that operating cost in huge plants is decreased.
6. Because it can be used in low voltage (8.5V), there is no limitation in controller.
7. Variable orifice is applied and so in case of small actuator the hunting is controlled to the optimum condition during operation.
8. Optionally it can be used outputting feedback signal.
9. Optionally it can be used Electro- limit switch.
10. Split range such as 4-20mA, 12-20mA are available.
11. The pressure of Air filter regulator is sent to Actuator directly with using A/M switch.
12. PD parameters can adjusted in sensitiveness and specific action.
13. Ex ia IIB T6 protection grade because of structure of intrinsically safe type.  
(Be in progress)
14. It has IP 66 Protection grade.
15. Air filter regulator can be attached with the product with only one linear nipple without extra piping.
16. Because of Epoxy polyester powder coating, it can be used for long period of time in corrosive air.
17. Because of simple and modulized inner structure, maintenance is very easy.

## Nameplate Description

### Model number

Product model name and additional option codes.  
Refer the next chapter for detailed ordering number.

### Explosion Proof

Explosion proof grade applied to the product.  
It has Ex ia IIB T6 intrinsically safe type grade.

### Protection

Protection grade applied to the product.  
It has IP66 protection grade.

### Input signal

Current input signal range.  
DC 4-20mA current is used.

### Ambient temperature

Ambient temperature range for operating product.  
Standard ambient temperature is -20°C to 70°C.

### Supply pressure

Supply pressure range inputting product.  
It is set as 1.4-7 kgf/cm<sup>2</sup> (0.14-0.7 MPa).

### Serial number

The numbers given each product.  
By tracking this number various information for the item can be collected.

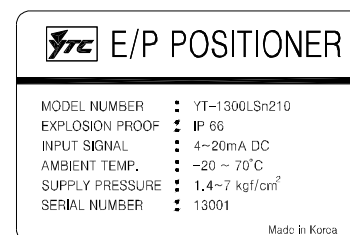

YT-1300 Label

## Ordering number

YT-1300 series use the following ordering numbers.

**YT-1300** □ □ □ □ □ □ □ □ □ □ □ □ □ □

1. Motion type	L : Linear R : Rotary
2. Acting type	S : Single acting D : Doble acting
3. Explosion proof	n : Non explosion proof I : Ex ia IIB T6 (note 1)
4. Feedback lever (YT-1300L)	1 : 10 ~ 40 mm 2 : 20 ~ 70 mm 3 : 50 ~ 100 mm 4 : 100 ~ 150 mm (note 2)
Feedback lever (YT-1300R)	1 : M6 x 40L 2 : M6 x 63L 3 : M8 x 40L 4 : M8 x 63L 5 : Namur standard
5. Connection type	1 : PT 2 : NPT 0 : None
6. Option	1 : Position transmitter 2 : Limit switch 3 : Position transmitter & Limit switch

Note 1. No.3 Intrinsically safe type is in progress.

2. No. 4 lever (100 ~ 150mm) is connected one of No. 2 and No. 3 lever.

## Specification

Model	YT-1300L		YT-1300R	
	Single	Double	Single	Dpuble
Acting Type				
Input Signal	4~20 mA DC			
Supply Pressure	1.4~7kgf/cm <sup>2</sup> ( 0.14~0.7 MPa )			
Stroke	10 - 150 mm		60 - 90°	
Impedance	Max.500 Ohm/20mA DC			
Air Connection	PT 1/4, NPT 1/4			
Gauge Connection	PT 1/8, NPT 1/8			
Conduit Entry	PF 1/2(Standard), NPT1/2(Option)			
Explosion Proof	Ex ia IIB T6			
Protection	IP66			
Ambient Temperature	-30~80℃			
Linearity	±0.5% F.S.			
Hysteresis	0.5% F.S.			
Sensitivity	±0.2% F.S			
Repeatability	0.3% F.S.			
Flow Capacity	70 LPM			
Air Consumption	below 2 LPM (sup=1.4K)			
LCD Temp. Condition	Storage Temp:-30~85℃, Operating Temp:-10~70℃			
Vibration Effect	6G			
Humidity	5-95% RH at 40℃			
Communication (Option)	below DC 24V			
Feedback Signal (Option)	4-20mA ( DC 10 - 30V )			
Material	Aluminum Diecasting			
Weight	1.5 kg (3.3 lb)			
Painting	Epoxy Polyestere Powder Coating			
Color	Black			

1. Based on temperature 20℃, absolute pressure 760mmHg and relative humidity 65%

2. Contact us for the product beyond the specification.

3. To change Product color or to use user's own label is available, but they are limited to the big volumes of quantity. Contact our sales dept.

## Structure

The structure of YT-1300L is as follows. That of YT-1300R is as same as linear type except feedback lever.

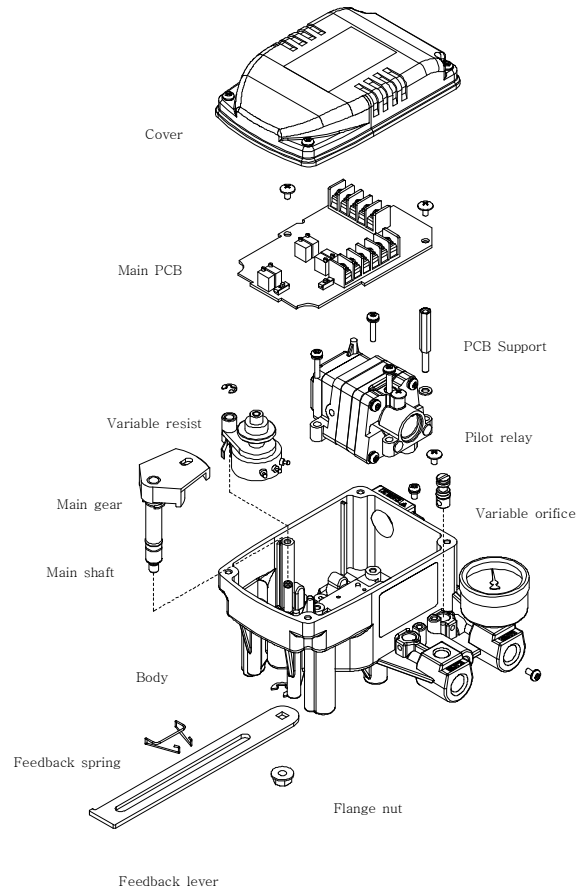

YT-1300 structure

## Installation

### Note

When the positioner is installed with the actuator or replaced, ensure the followings.

- All inputs and supply pressure to valve, actuator and other instrument must be shut down.
- In order entire system not to shut down the control valve must be separated from the system by bypass valve or other equipment.
- No pressure remains in the actuator.

### YT-1300L drawing

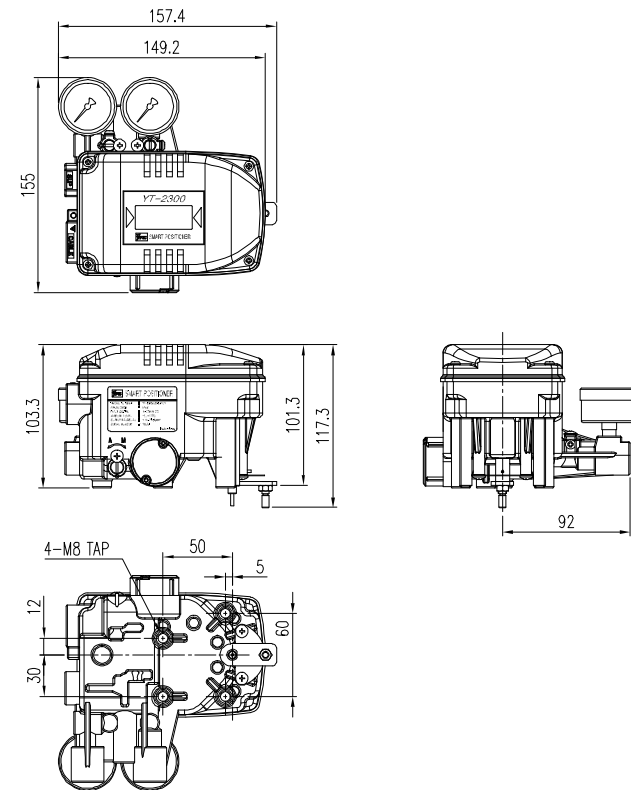

YT-1300L drawing

YT-1300R drawing

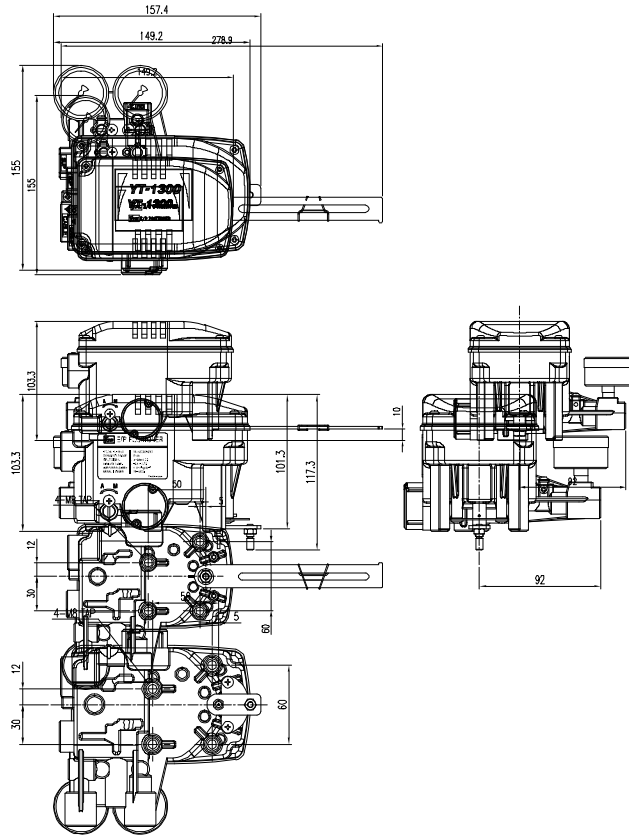

YT-1300R drawing

\* The brackets for attaching on the actuators are made by using these drawings and they are also used for checking piping, etc.

## Tools for installation

Tools and bolts used for assembly are,

1. Hexagonal wrenches
2. (+) screw driver
3. (-) screw driver
4. Spanners for hexagon head bolts

## YT-1300L installation

YT-1300L is used for linear motion valve such as globe valve or gate valve using spring return type diaphragm actuator or piston actuator. YT-1300L consists of the following components. Be sure that all the components are prepared.

1. YT-1300 main body
2. Feedback lever and lever spring
3. Flange nut (attached on the bottom of main shaft of YT-2300L body)
4. 4pcs of Hexagon head bolt M8x1.25P
5. 4pcs of M8 plate washer

## YT-1300 installation example

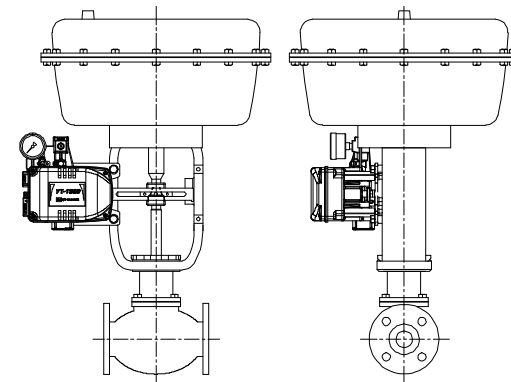

YT-1300L installation example

## Installing YT-1300L with bracket

1. First of all, it is necessary to make proper bracket to attach on actuator yoke.  
The most important things in making bracket are as follows.

- 1) YT-1300L feedback lever should be level at 50% of valve stroke. (Refer to no. 7 in this chapter.)
- 2) Feedback lever connection bar of actuator clamp should be connected at the position that valve stroke and the numbers carved on feedback lever is fitted. (Refer to no. 8 in this chapter.)

If the bracket meets the above conditions, YT-1300L is installed very easily.

2. Assemble YT-1300L and bracket with bolts. Use standard bolts in bolt holes on the backside of YT-1300L. The standard of bolt screw is M8x1.25P and other bolt standards are available as option. For details, contact our sales dept.

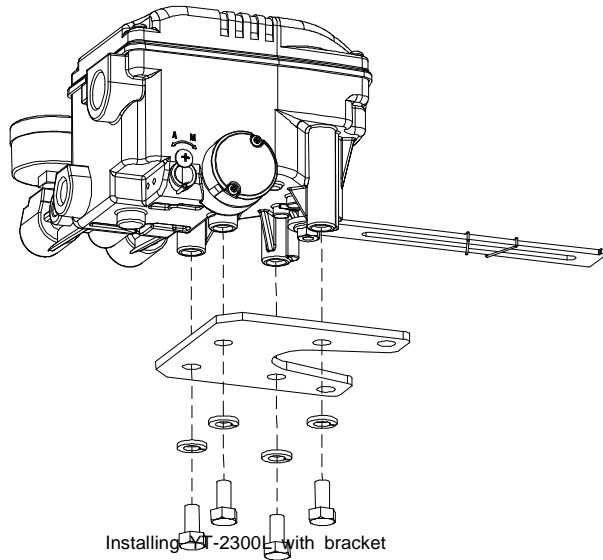

3. After assembling YT-1300L and bracket with bolts, attach it with using bolt holes of actuator yoke. But do not attach completely. There must be some space.

4. Install bar connected with YT-1300L feedback lever on the actuator clamp. The slot length between YT-1300L feedback lever is 6.5mm, so the diameter of connection bar should be less than 6.3mm.

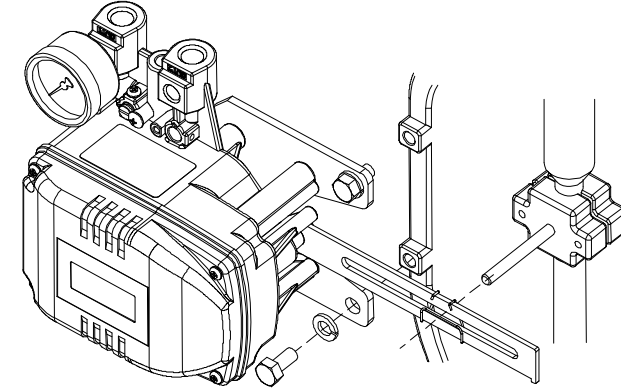

Installation of actuator clamp and connection bar

5. Connect air filter regulator with the actuator temporarily. Set supply pressure of air filter regulator in order that actuator clamp is positioned at 50% of valve stroke.

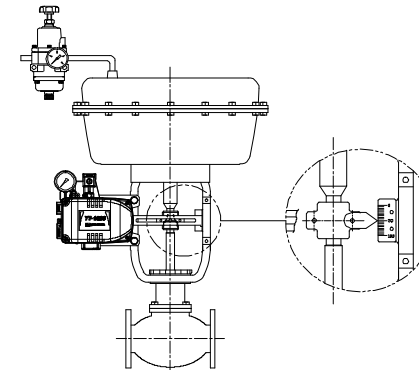

Connection of supply pressure pipe between actuator and air filter regulator

6. Insert connection bar attached on actuator clamp into the slot of YT-1300L feedback lever. Ensure that inserting should be the following picture in order to reduce hysteresis.

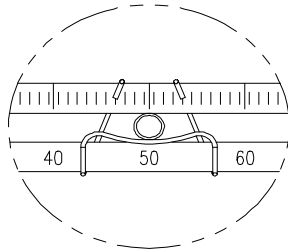

The connection bar inserted correctly between feedback lever and lever spring

7. Check if YT-1300L feedback lever is level at 50% of valve stroke. If not, make it be level with moving bracket or feedback link bar. If YT-1300 is installed not being level at 50% of valve stroke, product linearity becomes worse.

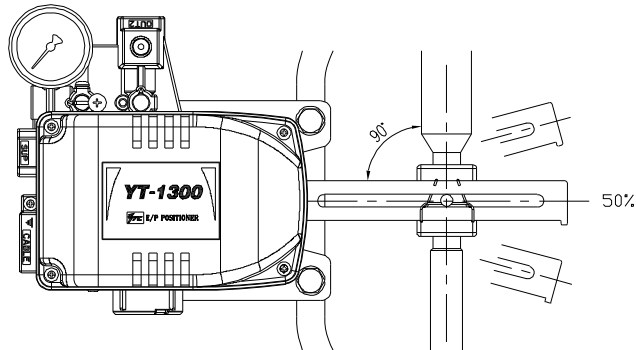

Feedback lever being leveled correctly

8. Check valve stroke. The numbers indicating stroke are carved on the YT-2300L feedback lever. Set connection bar attached on actuator clamp on the number on

feedback lever applicable to valve stroke as the following picture. To set the connection bar and the number, move the bracket attached on YT-1300L or connection bar from side to side.



Stroke 30mm

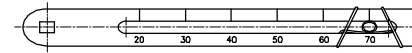

Stroke 70mm

Installation position of connection bar for valve stroke

**Note**

After installation, operate valve from 0 stroke to 100% stroke with using air filter regulator on the actuator. When the stroke is both 0% and 100%, feedback lever should not be reached to the lever stopper on the backside of YT-1300. If feedback lever reaches to the lever stopper, move attachment position of YT-1300L to the direction becoming more distant from yoke center.

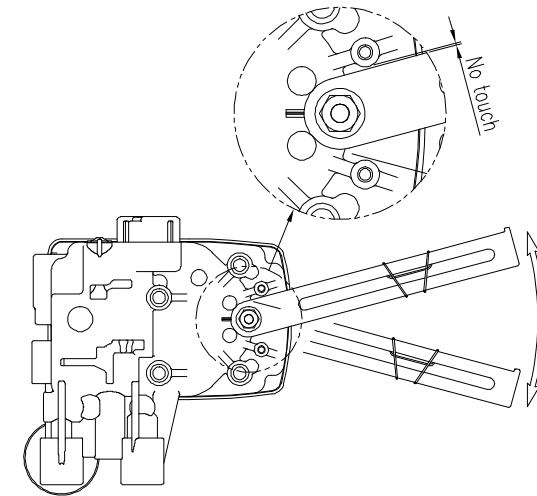

Check whether or not lever stopper and feedback lever is contacted

9. If YT-1300L is installed accurately as above procedures, lock the bolts and nuts of bracket and feedback lever connection bar completely.

## YT-1300R installation

YT-1300R is used for rotary motion valve such as ball valve or butterfly valve using rack and pinion, scotch yoke or complex type actuator whose stem is rotated 90 degrees. YT-1300R consists of the following components.

1. YT-1300R main body
2. Fork lever and lever spring to attach on actuator
3. 1 set of bracket
4. 4pcs of Hexagon head bolt M8x1.25P
5. 4pcs of M8 plate washer

### YT-1300R installation example

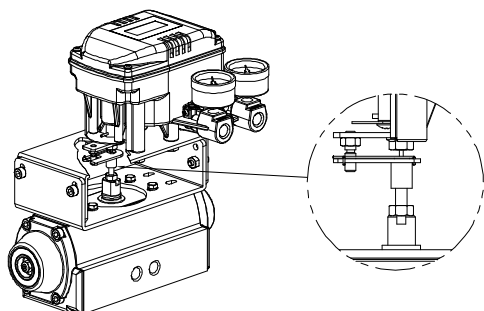

YT-1300R installation example of fork lever

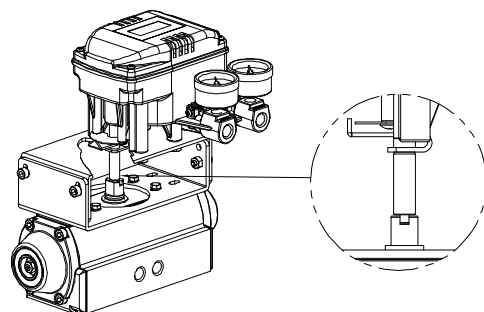

YT-1300R installation example of Namur shaft

## Installing YT-1300R with bracket

YT-1300R is supplied with standard bracket. The bracket is consists of 2 part and can be used with Fork lever and Namur shaft. The bracket is assembled in the factory as based on 20mm of actuator stem height. But if actuator stem height is higher than that like 30mm, 50mm, reassemble the bracket adjusting to the height. Referring to the following table, check the hole positions.

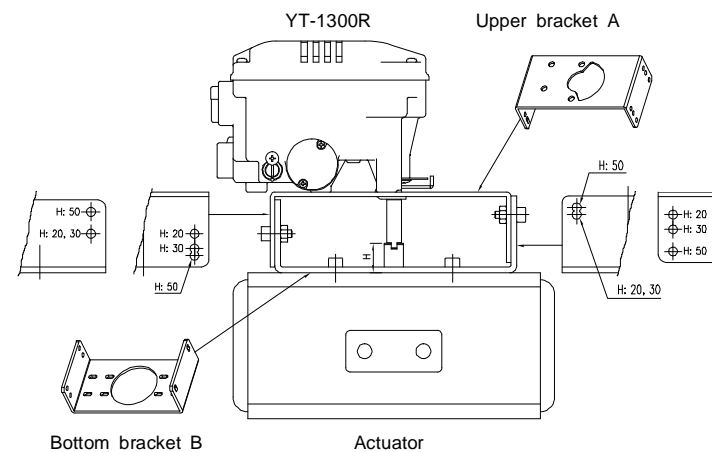

Bracket assembly method by actuator stem height H

Actuator stem height (H)	Markings of bolt holes			
	A-L	B-L	A-R	B-R
20mm	H : 20	H : 20, 30	H : 20	H : 20, 30
30mm	H : 30	H : 20, 30	H : 30	H : 20, 30
50mm	H : 50	H : 50	H : 50	H : 50

Ex) In case that H is 30mm, A-L should be locked in H:30 hole and B-L in H:20,30, A-R in H:30, B-R in H:20,30 with bolts.

Table: Bracket assembly method by actuator stem height H

1. Usual types of actuator stem height (H) are 20, 30 and 50mm. After checking H, assemble brackets as explained on the previous page. The bracket is set as 20mm type in the factory.

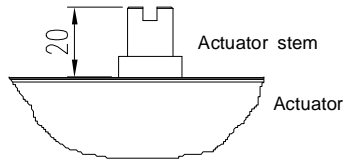

Actuator stem height (H=20mm)

2. Attach bracket to the actuator using hexagon head bolts or wrench bolts. Diameter of bracket bolt holes is 6mm. Use spring washers or any other equipment so as the bolts not to be loosened by vibration or impact. The direction of bracket is different by operating conditions, but normal direction is as following picture. That is, when the piping of actuator and YT-1300R is direction A, bracket hole and indicator attached on the bottom of YT-1300R main shaft should be same direction as being half circle.

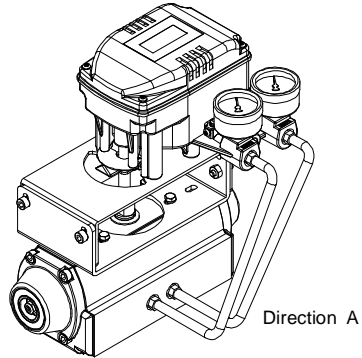

Attachment direction of bracket and actuator

3. Set rotation position of actuator stem as initial zero point which is stroke 0%. In case of spring return type single actuator, since the actuator stem is always rotated at zero point without supply pressure, it is easy to check zero point. If the actuator is double acting, check that whether it is clockwise or counter clockwise or the rotation direction of actuator stem with using supply pressure.

4. Set actuator stem as initial zero point and install fork lever as the following picture. Ensure the position of initial zero point when actuator stem is clockwise or counter clockwise. Installation angle of fork lever should be about 45 degree based on the linear shaft. But the angle is not related to Namur shaft.

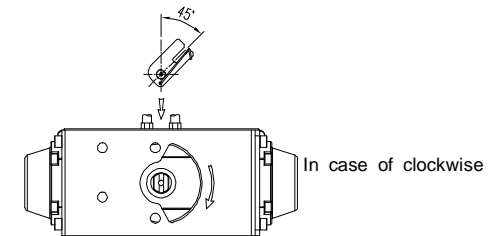
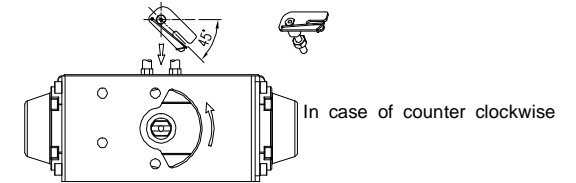

Installation position of fork lever

5. If the fork lever position is set, lock check nuts assembled on the bottom of fork lever with turning clockwise. Set the upper height of fork lever as 6-11mm lower than bracket upper height.

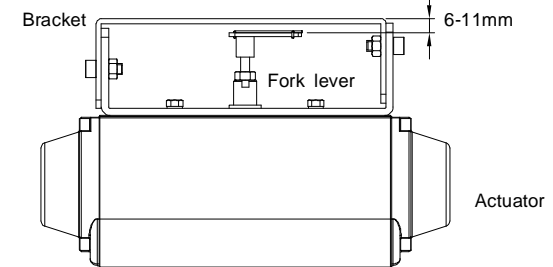

Height of bracket, fork and fork lever

6. Attach YT-1300R to the bracket. Fix the clamping pin on the main shaft center of YT-1300R into the hole of fork lever and insert connection bar attached on the main shaft lever into fork lever slot to be locked fork lever spring. This is to fit the main shaft of YT-1300R and the center of actuator stem. If they are not fitted, product durability is getting worse due to too much force on the main shaft of YT-1300.

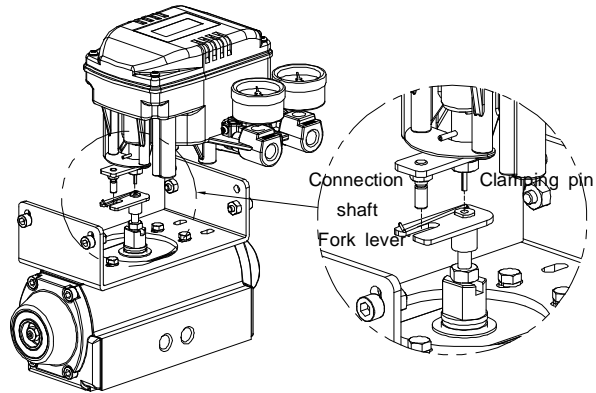

Fitting the pin on the YT-1300R main shaft into fork lever hole

7. Fix YT-1300R base and the bracket with hexagon head bolts and plate washer. It is better to lock the bracket and YT-1300R after checking the position of YT-1300R inserting four bolts.

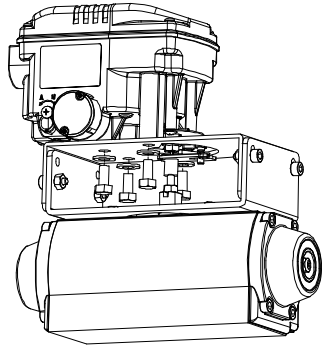

Assembly status of YT-1300R

## Piping connection

### Note

1. To prevent moisture, oil and dust from being led into the product, give careful consideration to the choice of supply pressure compressor and its system.

2. We recommend to attach filter or air filter regulator in front of supply port of YT-1300.

### Conditions of supply pressure

1. Dry air whose dew point is at least 10°C lower than that of ambient temperature.
2. Be free from solid particles as a result of being passed through 5 $\mu$ m or finer filter.
3. Not contain oil or lubricating oil.
4. Comply with ANSI/ISA-57.3 1975(R1981) or ISA S7.3-1975(R1981).
5. Not used beyond the range of 1.4 - 7 kgf/cm<sup>2</sup> (140 - 700 kPa).
6. Set supply pressure of air filter regulator as 10% higher than operating pressure of actuator of spring range pressure.

### Conditions of pipe

1. Remove foreign objects inside of pipe.
2. Do not use squeezed or broken pipe.
3. To maintain flow rate of YT-1300, use the pipe whose inner diameter is more than 6mm (outer diameter 10mm).
4. Do not connect the pipe too long. It affects flow rate due to the friction inside the pipe.

## Piping connection with actuator

### Single acting actuator

YT-1300 series single acting type is set to use OUT1 port. Therefore, in case of using single acting type of spring return actuator, OUT1 port should be connected with supply pressure port of actuator.

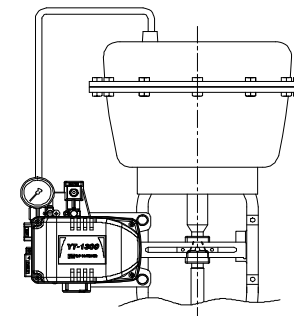

Piping connection example of YT-1300L with single acting actuator

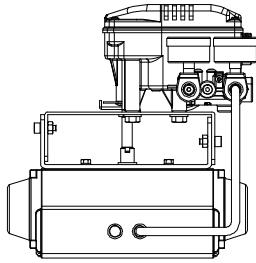

Piping connection example of YT-1300R with single acting actuator

### Double acting actuator

In case of YT-1300 series double acting type, when input current signal, supply pressure is out from OUT1 port.

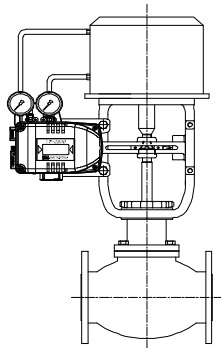

Piping connection example of YT-1300L with double acting actuator

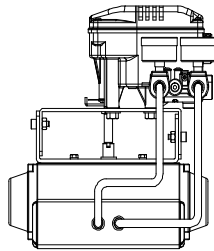

Piping connection example of YT-1300R with double acting actuator

### Power connection

#### Note

1. Before connecting terminal, power must be shut off.
2. Use ring type terminal against oscillation, impact, etc.
3. YT-1300 series (except PTM and L/S included type) use DC 4-20mA as power.
4. If structure of explosion need to area according to explosion rule of their area have to power connection.
5. Safety Barrier set controller or DSC system of safety area for keep the intrinsically safe type. Here is the Safety Barrier specification.
6. In case of PTM type, additional power should be supplied to PTM separately. Supply voltage is 9-27V and must not be exceeded 30V.
7. In case of Limit Switch type, additional power should be supplied L/S separately. Supply voltage is not exceeded DC 24V.
8. In order to protect the product the ground terminals should be grounded.
9. Use twisted cable which conductor sectional area is 1.25mm<sup>2</sup> and is suitable for 600V as on conductor table of NEC Article 310. Outer diameter of cable should be 6.35-10mm. Use shield wire against electromagnetic wave and noise.
10. Do not install the cable near the equipment such as high-capacity transformer or motor generating noise.

The following is terminal part of YT-1300 series.

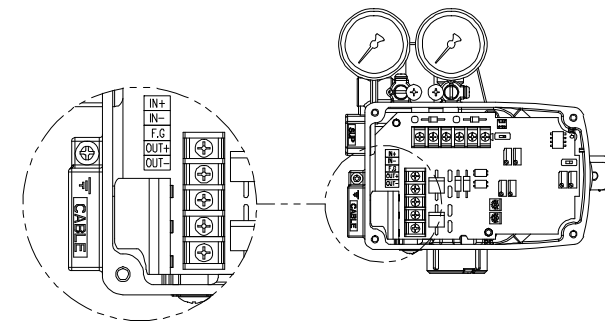

Terminal plate of YT-1300

### Terminal connection of current input signal

1. Open cover by loosening 4pcs of M4 bolts of product cover.
2. Loosen terminal locking bolts of terminal plate receiving current input signal.

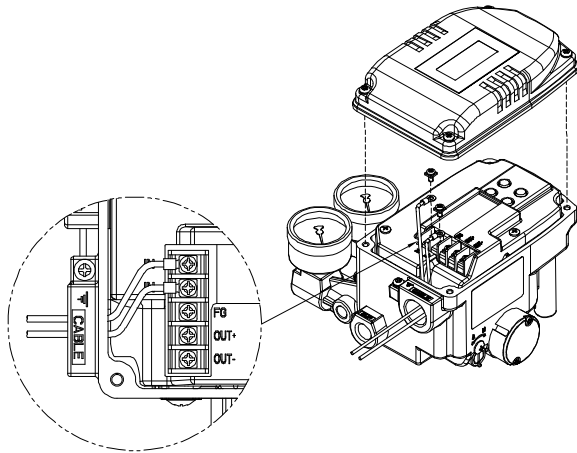

Terminal connection of current input signal

3. Insert a cable through cable connector in YT-1300.
4. Use ring type as cable terminal in order not to come out.
5. Insert terminal bolts in terminal holes of cable and lock them with + terminal and - terminal each on terminal plate. Tighten terminal bolts with 1.5Nm (15kgfcm) torque.
6. Be sure not to change the polarity of terminal.

### Terminal connection of feedback signal

1. Open cover by loosening 4pcs of M4 bolts of product cover.
2. Loosen terminal locking bolts of feedback signal for position transmitter on terminal plate.

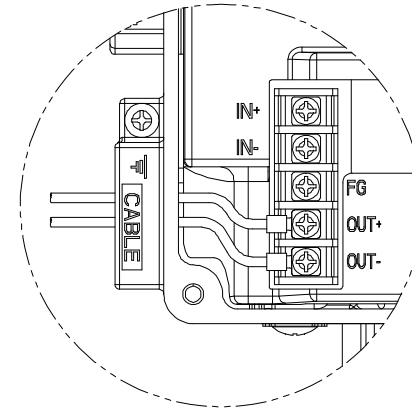

Terminal connection of transmitter

3. Insert a cable through cable connector in YT-1300.
4. Use ring type as cable terminal in order not to come out.
5. Insert terminal bolts in terminal holes of cable and lock them with + terminal and - terminal each on terminal plate. Tighten terminal bolts with 1.5Nm (15kgfcm) torque.
6. Be sure not to change the polarity of terminal.

## Terminal connection of limit switch

1. Open cover by loosening 4pcs of M4 bolts of product cover.
2. Loosen terminal locking bolts of feedback signal for position transmitter on terminal plate.

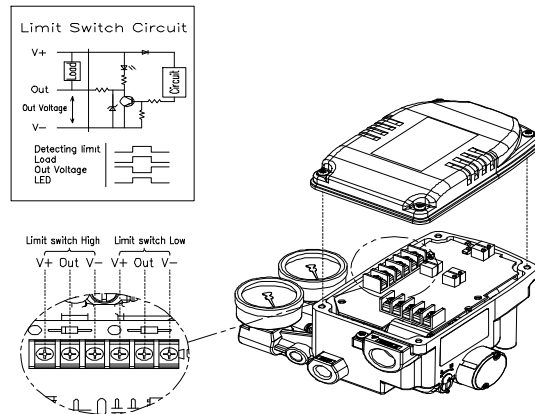

Terminal connection of limit switch

3. Insert a cable through cable connector in YT-1300.
4. Use ring type as cable terminal in order not to come out.
5. Insert terminal bolts in terminal holes of cable and lock them with + terminal and - terminal each on terminal plate. Tighten terminal bolts with 1.5Nm (15kgfcm) torque.
6. Above the drawing, 3pieces terminal of left are located 100% open valve, 3pieces of terminal of right are located 0% open valve.
7. Be sure not to change the polarity of terminal.

## Inner terminal connection for ground

1. The ground is necessary for the safety of YT-1300 series and system.
2. There are inside terminal in the center of terminal plate and outside terminal beside outer cable entry. Using any ground terminal is available and resistance must be less than 1000hm.

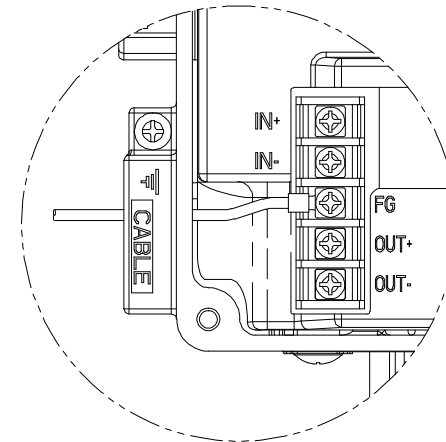

Ground terminal connection

3. In case of using inside ground, open cover by loosening 4pcs of M4 bolts of product cover.
4. In order to maintain the ground safely, use ring type as ground cable terminal to prevent it coming out.

## A/M switch (Auto/Manual switch)

There is A/M switch on the bottom of YT-1300. If this switch is set as auto, supply pressure is transmitted to actuator by the operation of YT-1300 and if it is set as manual, supply pressure of air filter regulator is transmitted to actuator regardless of YT-1300.

\* When A/M switch is set as manual, ensure that too much pressure must not be transmitted to the actuator.

1. Check if the supply pressure of air filter regulator is too high.
2. Turn the switch clockwise and supply pressure of air filter regulator is transmitted to actuator.(take 1~2 round)
3. If turn the switch counter-clockwise, YT-1300 is operated normally. (take 1~2 round)

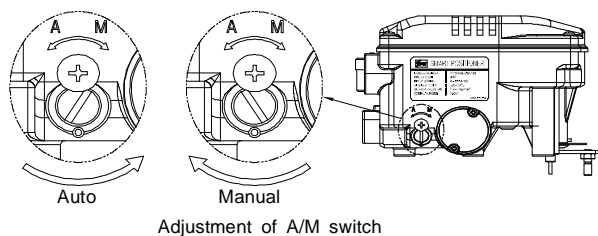

## Variable orifice

The actuator volume is too small, hunting can be occurred. In this case, adjust variable orifice with using (-) driver, then hunting is prevented by reducing flow rate of supply pressure transmitting to actuator.

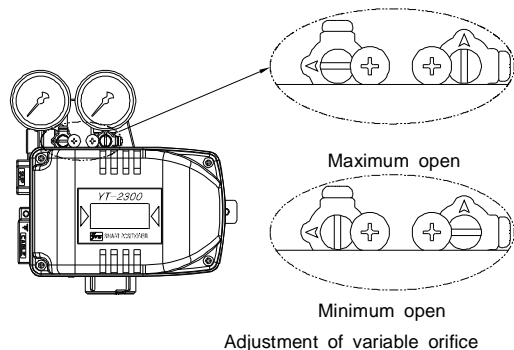

## Calibration

Warning : Since this makes valve or actuator move, before auto calibration valve must be separated from entire system.

### Explanation of Adjustment

Board of YT-1300 Series have power relate terminal plate 2set, variable resistor 3set and PD adjustment 1set.

Terminal plate is relate terminal block of positioner, position transmitter and limit switch, also adjustment variable resistor has positioner, transmitter, limit switch each variable resistor. Location and explain about the parts are as follows :

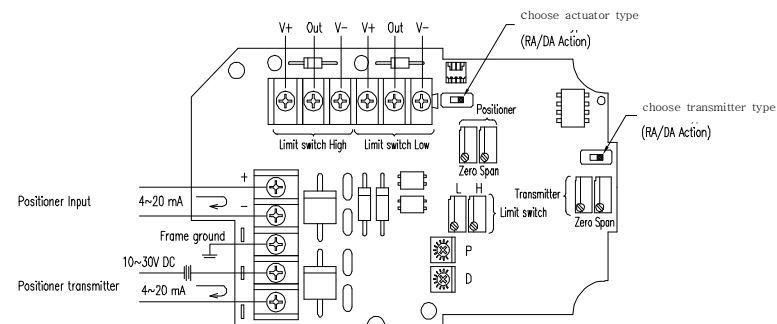

Location of terminal block and variable resistor above board

- (1) -1 : input signal to positioner
- (1) -2 : positioner, direct/reverse action convert switch
- (1) -3 : positioner, adjustment zero/span variable resistor
- (1) -4 : positioner, restrain of P, adjustment of D restrain variable resistor
- (2) -1 : position transmitter input/output signal (2 wire) terminal
- (2) -2 : position transmitter direct/reverse action convert switch
- (2) -3 : position transmitter adjustment of zero/span variable resistor
- (3) -1 : limit switch input/output signal terminal plate
- (3) -2 : limit switch perception location adjustment of switch
- (4) -1 : inner grounding terminal

## Calibration of Positioner

Calibration of positioner used to adjust sign switch of <POSITIONER-SW> and sign variable resistor 2 piece of <P-SPAN>, <P-ZERO>, also sign variable resistor 2 piece of <P>, <D>. Each location of adjustment reference to 'explain of adjustment'.

About each method of adjustment, explain to detail as follows.

### POSITIONER-SW

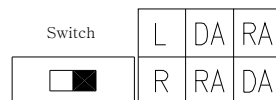

According to direction action or reverse action of operation direction of actuator, operation direction of positioner agreement. In this switch is agreed to operation direction of positioner. According to linear and rotary type, it have to opposite setting direction. If operator method of actuator is RA to linear type, it should be pushing the right to switch, if DA, it should be pushing the left to switch.

### VARIABLE RESIST OF P-SPAN

Variable resistor of P-SPAN adjust span of positioner. If turn to clockwise, span value is increasing, If turn to counter clockwise, span value is decreasing.

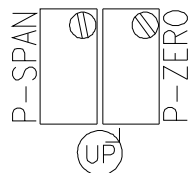

### ADJUSTMENT OF P-ZERO VARIABLE RESISTOR

P-ZERO variable resistor adjust zero point of positioner. If turn to clockwise, zero point is up, If turn to counter clockwise, zero point is down.

### VARIABLE RESIST OF P PARAMETER

Variable resistor of P parameter adjust to restrain value of P. What is the restrain of P, according to error %, it is proportional constant value of compensate signal. Although restrain value of P is getting bigger, according to input signal, quickly find to locate, easy to occur hunting, otherwise if restrain value of P is getting smaller, fall down the precision.

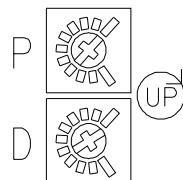

## VARIABLE RESIST OF D PARAMETER

Variable resistor of D parameter adjust to restrain value of D. What is the restrain of D, according to variation ratio of error %, add to fines constant value of original compensate signal through variation of compensation value. If restrain value of D is getting bigger, easy to occur hunting, if getting smaller, it is find to locate own course which able to worse the same property. If turn to clockwise, restrain value of D is increasing, if turn to counter clockwise, restrain value of D is decreasing.

### Calibration procedure

- (1) It will be right to check installing method and power connection for positioner, if something is wrong, it have to reinstalling right way again.
- (2) Input 4mA electric current signal turn to P-ZERO variable resistor which is setting to valve stroke 0%.(in case of reverse). In case of direction, it is setting 100%.
- (3) Input 20mA electric current signal turn to P-SPAN variable resistor which is setting to valve stroke 100%(in case of reverse). In case of direction, It is setting 0%.
- (4) If it adjust to span, it will be changed Zero point, so it is processing to repeat again above (2),(3).
- (5) After zero and span adjust, it will be setting to adjust P, D parameter various resistor to the same property of valve stem.

## Calibration of Position transmitter

Calibration of position transmitter method is better to easy than method of positioner. Calibration of position transmitter adjust variable resistor 2pieces of <TR-SPAN>, <TR-ZERO> sign and switch of <TR-ACTION> sign.

### Adjustment of TR-ACTION SWITCH

It should be agree to increase and decrease direction of signal between positioner and position transmitter.

<TR-ACTION> switch agree to increase and decrease direction of signal for two instruments. If it is agree between input signal of positioner and output signal of position transmitter, when input signal of positioner has 4mA, if output signal of position transmitter also occur to 4mA, it have to set the pushing switch right to direction of <DIR>. On the other hands, if



it occur to opposite between input signal of positioner and output signal of position transmitter, when input signal of positioner has 4mA, if output signal position transmitter has 20mA, it have to set the pushing switch left to direction of <REV>.

### Adjustment of TR-SPAN Variable resistor

Variable resistor of indicate to TR-SPAN adjust to span of position transmitter. If turn to clockwise, span value is getting bigger, if turn to counter clockwise, span value is getting smaller.

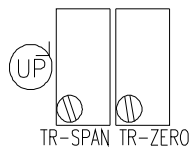

### Adjustment of TR-ZERO Variable resistor

Variable resistor of indicate to TR-ZERO adjust to zero of positioner. If turn to clockwise, zero point is up, if turn to counter clockwise, zero point is down.

### Calibration procedure

Calibration of position transmitter is same thing in positioner. Merely, Be careful to <TR-ACTION> switch direction.

### Calibration of Limit Switch

2pieces variable resistor adjust to use calibration <LIMIT-H>, <LIMIT-L> sign of limit switch. Limit switch is transistor formula which can use exclusively DC 24V, so it can not be used AC voltage and exceed DC voltage.

### ADJUSTMENT OF LIMIT-H LIMIT SWITCH

Variable resistor of LIMIT-H limit switch occur to signal of 20mA locate. In case of actuator of direction action, it occur to signal of stroke 0% point, on the other hand, in case of actuator of reverse action, it occur to signal of stroke 100% point. When close, it can be checked to operate to turn on the red LED light above limit switch plate.

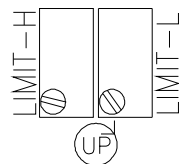

### Adjustment of LIMIT-L LIMIT SWITCH

Variable resistor of LIMIT-L limit switch occur to signal of 4mA locate. In case of actuator of direction action, it occur to signal of stroke 100% point, on the other hand, in case of actuator of reverse action,

### Calibration procedure <LIMIT-H>

- (1) It finished calibration of positioner.
- (2) It relate to power V+(H) terminal and COM(H) terminal, or V-(H) terminal and COM(H) terminal.  
When signal of Normal Open needed, relate to V+(H) terminal and COM(H) terminal, when relate to Normal Close, relate to V-(H) terminal and COM(H) terminal.
- (3) It input 20mA an electric current to positioner.
- (4) It can be checked to turn on the(Normal Open) red LED light above limit switch plate, if it doesn't turn on the light, variable resistor of LIMIT-H adjust until turn on the LED light. If it turn to clockwise, fixing point is going up, if it turn to counter clockwise, fixing point is going down.

### Calibration procedure <LIMIT-L>

- (1) It finished calibration of positioner.
- (2) It relate to power V+(L) terminal and COM(L) terminal, or V-(L) terminal and COM(L) terminal.  
When signal of Normal Open needed, relate to V+(L) terminal and COM(L) terminal, when relate to Normal Close, relate to V-(L) terminal and COM(L) terminal.
- (3) It input 20mA an electric current to positioner.
- (4) It can be checked to turn on the(Normal Open) red LED light above limit switch plate, if it doesn't turn on the light, variable resistor of LIMIT-L adjust until turn on the LED light. If it turn to clockwise, fixing point is going up, if it turn to counter clockwise, fixing point is going down.

## TROUBLE SHOOTING

Contents	Cause	Measures
Positioner is out of work, when input to electric current	supply pressure is very low	adjust to supply pressure
	terminal fixing bolt is loose	tight to terminal fixing bolt
	wrong relate to (+), (-)	right relate to (+), (-)
	trouble to PCB board	change to PCB board
	Piezo Unit is choked up	change to Piezo Unit
pressure of OUT1 piping rising until pneumatic regulator pressure, it is out of work to electric current signal	closed the A/M Switch	open to turn to counter clock wise A/M Switch
out put pressure occur only by A/M Switch	trouble to Piezo Unit	change to Piezo Unit
occur to hunting	volume of actuator is small	adjust to various orifice
	D restraint value is much big or small	adjust to D restraint value
	P restraint value is much big	reduce to P restraint value
actuator could not adjust to middle only ON/OFF work	OUT1 and OUT2 piping is changed	right relate to OUT1 and OUT2 piping
	RA/DA Action fixing to change	fixing to adjust RA/DA Action
linearity is not good	wrong relate to feedback lever	right relate to feedback lever
	wrong adjust to zero, span	again to adjust zero, span
	wrong installing positioner	right reinstalling positioner
much hysteresis	loose fixing patch of feedback lever	adjust to elasticity of fixing patch
	wrong setting up positioner	right resetting up positioner
	P restraint value much samll	raise to P restraint value
temporarily, it is not response to input signal, operate to turn on the power again	without ground or inferiority	right relate to ground
	trouble to PCB board	change to PCB board

### Yong Tech Co., Ltd.

ADD : 662-8, Pungmu-Dong, Kimpo-City, Kyeonggi-Do, Korea  
 TEL : 0082-31-986-8545  
 FAX : 0082-31-986-2683  
 E-mail : [vtc@vtc.co.kr](mailto:vtc@vtc.co.kr)  
 Homepage : <http://www.vtc.co.kr> , <http://www.positioner.biz>

This information contained in this catalogue is subject to change without prior notice  
 Please contact our web-site for the latest information.