

# Limitorque

*Limitorque Actuation Systems*

FCD LMABR1302-00  
(Replaces 130-10500)

Performance, value, and ease of use in multi-turn electric valve actuators



# Accutronix MX

# Accutronix™ MX:

the multi-turn valve actuators that deliver what you want most—control and ease of use.

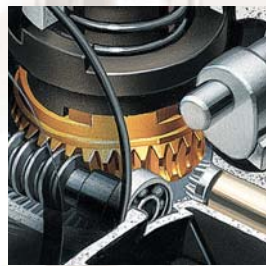



Limitorque set out to create the first actuator that would offer control without compromise—that is, reliability and high performance in an actuator that would also be remarkably easy to use. You'll discover that, with the Accutronix MX multi-turn electric valve actuator, Limitorque succeeded—on all counts.

**Engineered for Ease** Limitorque has created a product so advanced it's easy. Accutronix actuators offer time- and money-saving benefits through greater control, superior performance, solid strength and durability, and advanced monitoring and connectivity features. Accutronix actuators also make commissioning and operation easy with the most user-friendly human interfaces in the industry. And by surpassing the most rigorous testing of any actuator ever, Accutronix has proved itself to be remarkably reliable. Add other high-performance features, such as extensive internal logic and rugged construction—all in a unit that never needs a battery—and you've got an actuator that's easy to start with and easy to stay with: **Accutronix**.

# Accutronix MX speaks your language, whether it's management, technical, financial, operations, or service.



## Speed and simplicity

The Accutronix Control Panel features a 32-character LCD that provides actuator status and diagnostics in an easy-to-use, easy-to-read format. And it's multi-lingual, having the capability of operating in English, Spanish, German, French, Italian, and Portuguese.

Pipelines, production lines, and bottom lines coexist in perfect harmony with Accutronix MX. Engineering and finance share the benefits of a price/performance ratio second to none. Valve makers benefit when setting up the valve by saving time and lowering costs because of Accutronix MX's ease-of-use. Likewise, contractors benefit from the lower costs because Accutronix' streamlined human interfaces make

commissioning easy. In the plant, operators enjoy safe, predictable performance as well as lower training costs as a result of Accutronix' simplicity. Plant maintenance is able to troubleshoot quickly and easily—for further savings.

Accutronix MX electric valve actuators incorporate a range of features designed to address the way customers specify, install, and maintain

valve actuators. They offer control, reliability, and economy in clear and precise terms. Across-the-board in every phase of flow control operations, Accutronix MX actuators maintain 100% repeatable valve control—from quick, low-cost commissioning and reduced design cycle time to increased uptime, simplified maintenance, and ultimate reliability.

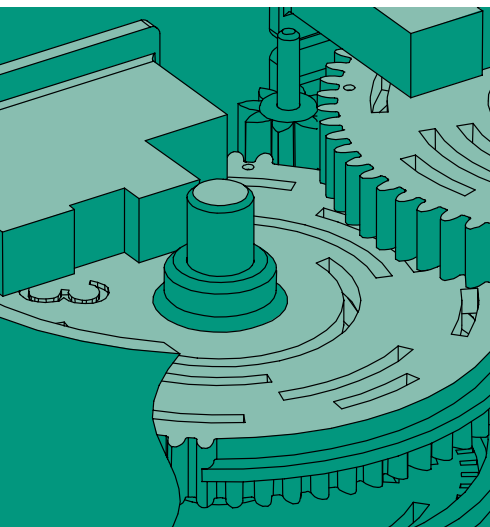

## Precision

An innovative 100% repeatable, patented absolute encoder provides optical sensing of valve position with 15-bit resolution. No battery or back-up power is required.

## Limitorque quality: rely on it

### Long life and easy maintenance

Double sealing of the terminal chamber protects Accutronix actuators even in harsh environmental conditions that can be encountered during initial commissioning. Should covers be removed to service the units or inadequately sealed conduits leak, internal control components remain protected.

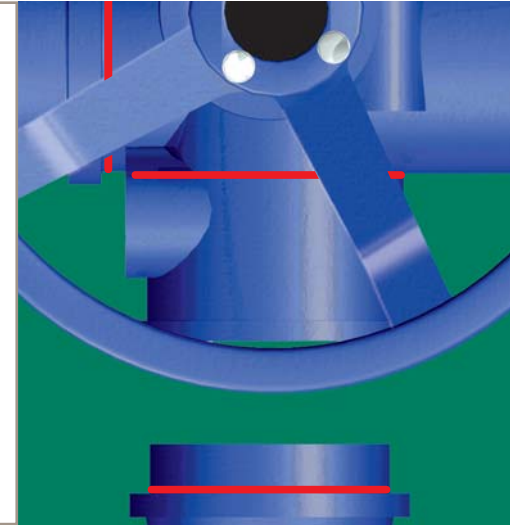

By building in nothing but the best, Limitorque responds to customers' needs to get the most out of their valve actuators. Quality is a way of life at Limitorque where the U.S. plant is certified to ISO 9001 standards, the recognized standard of

quality the world over. Limitorque routinely passes quality audits by demanding customers such as the U.S. Department of Energy and the U.S. Navy. The MX actuator complies with EC directives 89/392/EEC, 89/336/EEC, and carries the appro-

priate CE stamp. In addition, Accutronix actuators meet or exceed all relevant specifications of U.S. and international standards, including NEMA, CSA, ASTM, FM, SAA, ANSI, IEEE, IEC, and CENELEC.

### Quality and value

The powertrain is completely bearing-supported and immersed in extended-life synthetic oil. It consists of a hardened, rolled-steel worm and an alloy bronze worm gear with a design life of more than one million drive-sleeve turns.



## Accutronix anatomy: MX multi-turn actuators

Limiterque MX actuators respond to customer needs with advanced features designed for ease of commissioning and use, as well as time- and money-saving operational benefits. What sets Accutronix MX apart is the combination of control and reliability enabled by advanced Limitorque technology, plus superior ergonomics and human interfaces for speed, comfort, and ease of use.

*The reliable MX three-phase motor includes Class F insulation and thermal protection. It is designed specifically for valve actuator service, with a high starting torque and low inertia to reduce valve position overshoot.*

*Motor gear attachment allows the motor to be removed in one assembly for fast, easy inspection, repair, and maintenance.*

*Accutronix actuators feature a LimiGard™ circuit monitor that is designed for Fail/No-Action protection. LimiGard consists of dedicated circuitry that continually monitors the motor contactor, control relays, internal logic circuits, and external command signals to detect and alarm malfunctions.*

*Plug-in connectors permit quick and easy replacement of components.*

*Double-sealed design provides a termination chamber that is separate and sealed from the control chamber. Control components are never exposed to the elements during site wiring or because of a faulty cable connection.*

*External connection block has three power terminals, a ground screw, and 52 control screw-type terminals to simplify commissioning and upgrades.*

*Long-life gear set consists of hardened alloy steel rolled worm and bronze worm gear immersed in an extended-life synthetic gear oil. It is completely bearing-supported.*

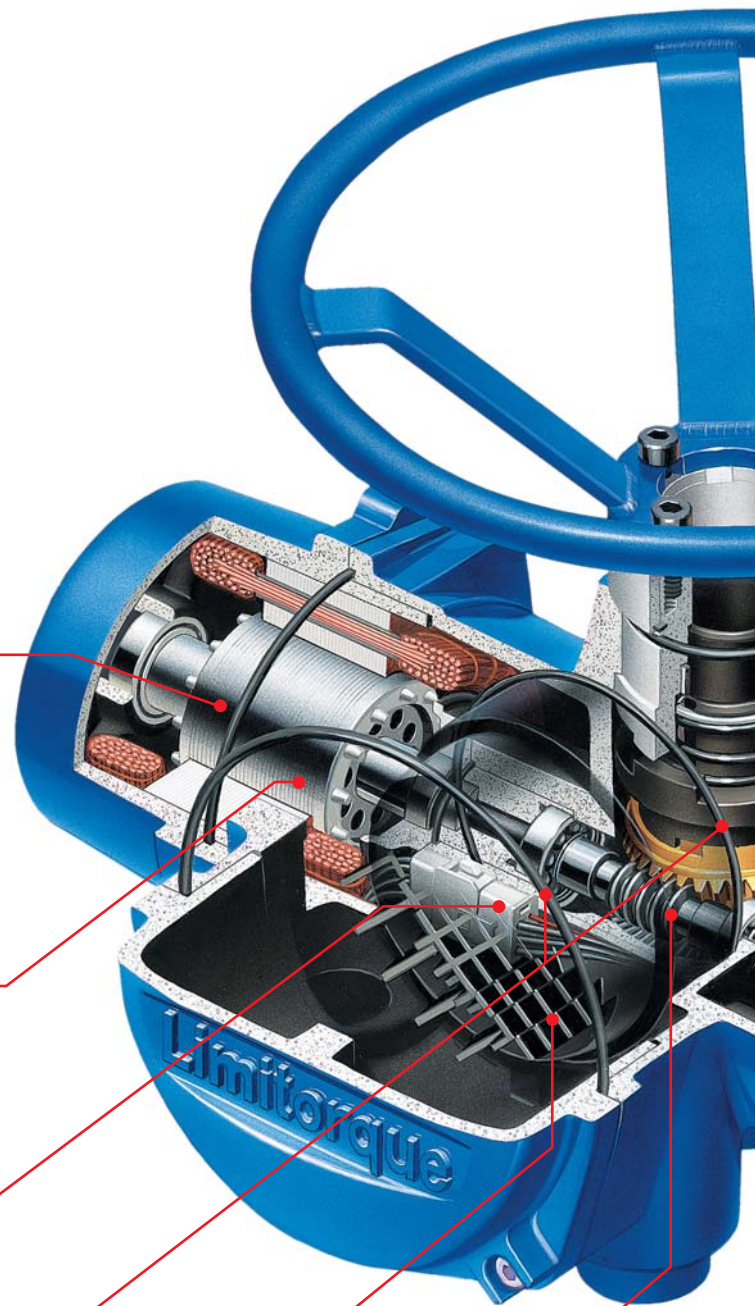

Limitorque Actuation Systems

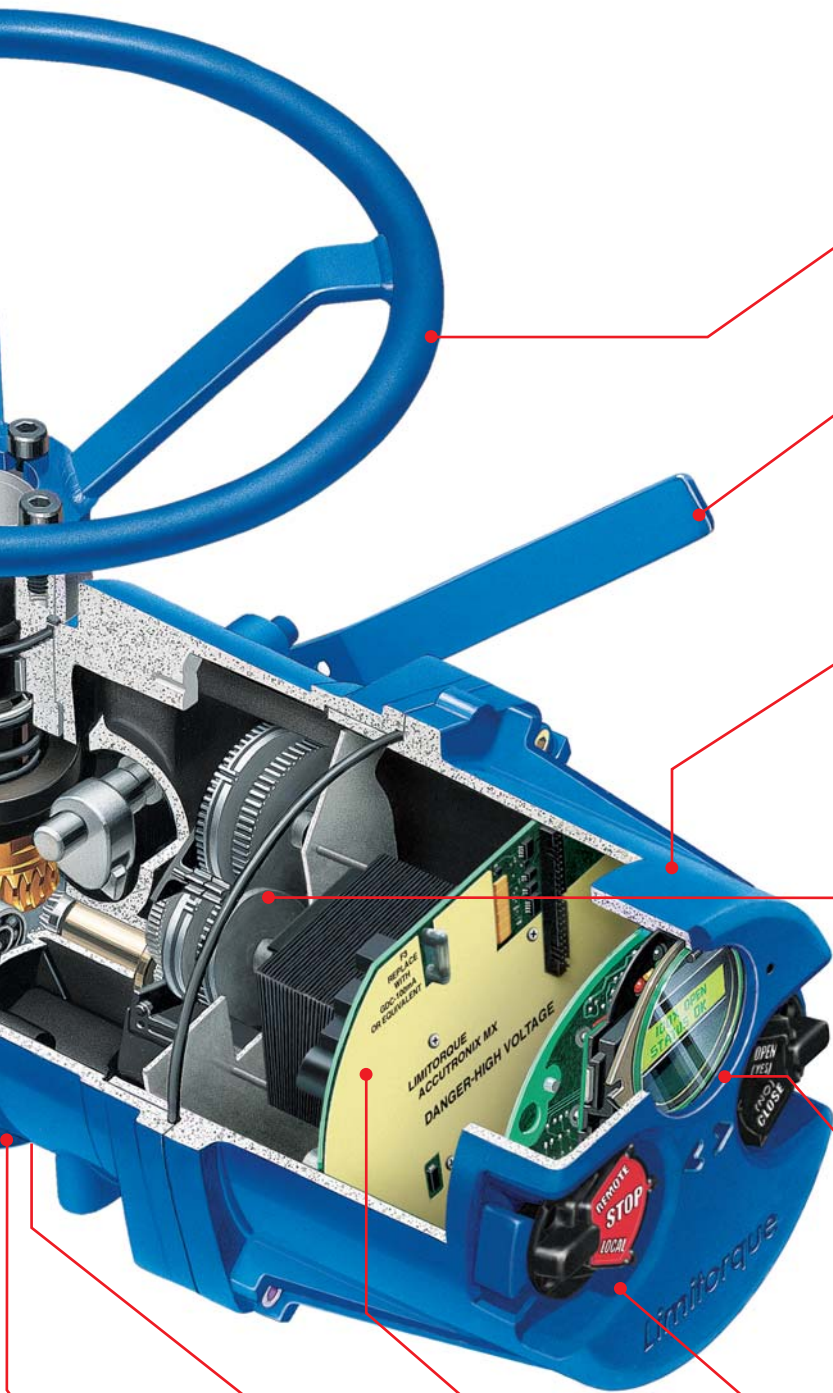

The MX heavy-duty handwheel provides backup for manual operation.

Declutch lever enables the MX actuator to be placed in manual, handwheel-drive operation. Lever automatically disengages when motor is energized and can be padlocked in the motor position.

Cast aluminum housing powder-coated for extreme environments.

Torque sensor derives output from motor speed, temperature, and voltage—and shuts off the motor to protect the actuator and valve if the set torque is exceeded.

Optionally, controls may be powered from an external 24 VDC source as backup for AC power. Controls and display will remain active through loss of AC power.

The absolute encoder, a key that enables MX actuators to achieve 100% repeatable control, provides optical sensing of valve position with 15-bit resolution. The encoder measures valve position in both motor and handwheel operation.  
**No battery or back-up power supply is required.**

Ductile iron thrust base is removable from main actuator housing for easier valve installation and maintenance.

High-strength, bronze alloy stem nut is removable for machining to suit the valve stem.

The control chamber includes an electronic control, monitoring, and protection module mounted on steel plate. Plug-in connectors allow fast, error-free removal and replacement of the module.

Local control switches make setup and calibration easy, using “yes” or “no” responses to straightforward questions, plus they provide the ability to open, stop, and close the actuator and to select remote or local preferences.

The control panel display delivers instant, up-to-the-minute actuator status and valve position. It also provides simple calibration and diagnostic information, including motor, identification, and hardware data, as well as torque profile and log reports.

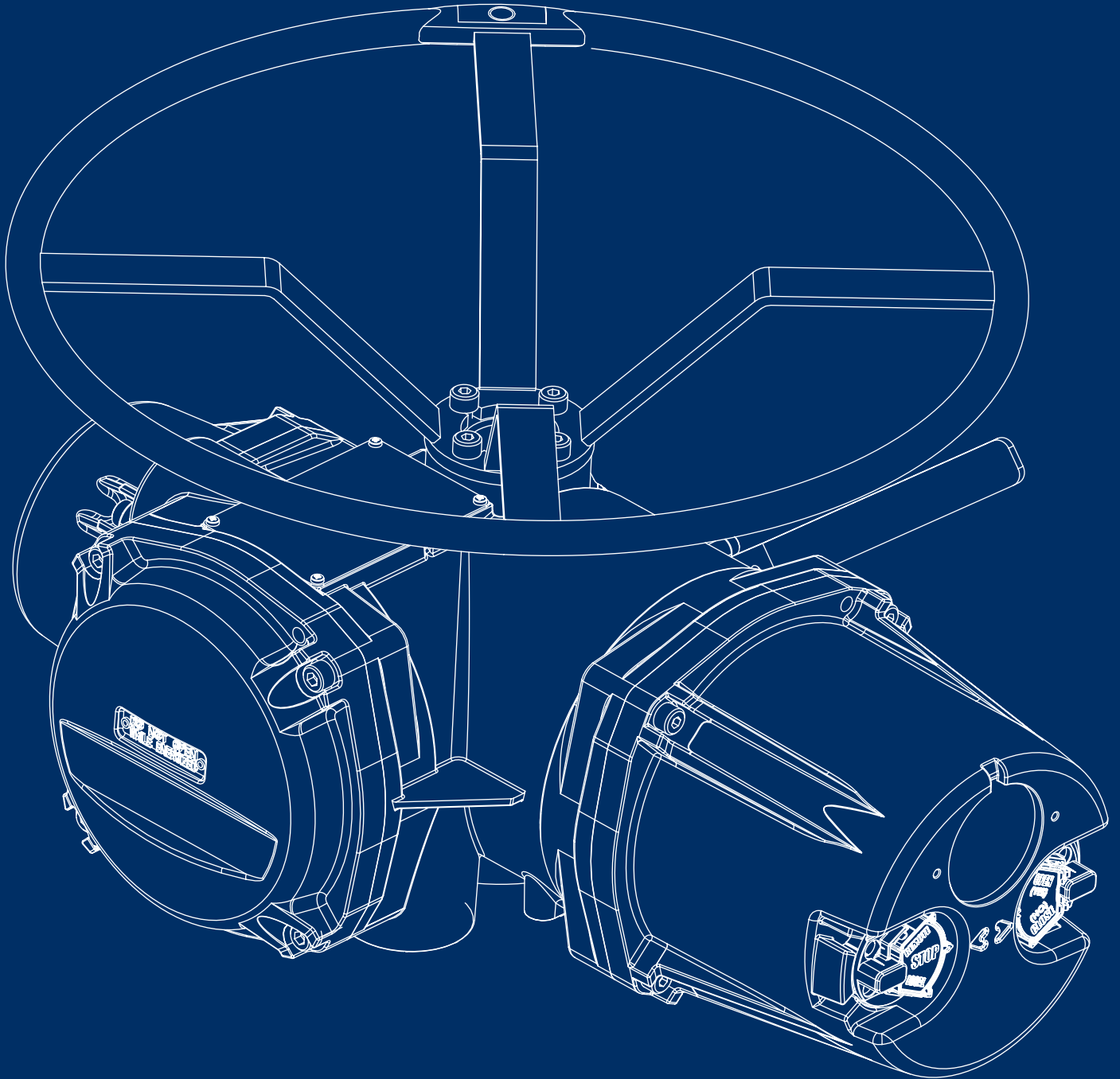

# Control as easy as 1 – 2 – 3

For valve adaptation/field commissioning, routine valve operation, and plant maintenance, users want three types of efficient, but powerful methods of control:

- 1 – Calibration/setup
- 2 – Normal operation
- 3 – Diagnostics

Drawing on more than 70 years of experience, Limitorque has responded to customer desires to simplify valve control automation by making the MX control panel as easy as 1, 2, 3. Accutronix' dialog-based human interface combines a 32-character LCD with two local control switches to form a control panel that puts complete control and confidence into the hands of the people you depend on to maintain operations.

The Accutronix control panel is rugged and environmentally sealed, yet clear and easy to read. Local control switches command valve action and reconfiguration of control parameters. Three LEDs continuously signal open, mid-travel, or closed status, regardless of control panel mode.

## Easy, yet accurate

The self-guided configuration dialog is performed by simply using the local control switches to respond “yes” or “no” to a series of questions. Accutronix MX actuators may be completely configured on-the-spot through the Accutronix control panel. Reference manuals are rarely needed for in-the-field activities—in fact, no additional equipment is required.

Enhancing the control panel's ease of use is its multi-language capability. The dialog is available in English, Spanish, German, French, Italian, and Portuguese. Under normal conditions, the LCD shows a “STATUS OK” message, which is accompanied by a valve position read-out—“100% OPEN.” If conditions deviate from normal, the “STATUS OK” message is replaced by an alarm message—“OVERTORQUE” for example. The alarm message appears and clears automatically when the alarm condition no longer exists.

Should more detailed information be required to diagnose a particular condition, it's provided in the “VIEW DIAGNOS-

TICS” screens at the actuator. For example, a reference profile of past torque output levels, an operation log, hardware status and motor data, or current alarms can be selected and displayed on the LCD panel. The result is fast, accurate troubleshooting of processes and equipment.

To provide the benefit of securing the actuator against unauthorized changes to configuration parameters, a three-digit numeric password may be configured by the user.

## Additional local indications

Visual indicators are another form of quick, easy communications. Conventional valve status indication is provided by three LEDs, according to the following pattern:

- Red “On” – Valve fully open
- Red “Blinking” – Valve opening
- Green “Blinking” – Valve closing
- Green “On” – Valve fully closed
- Yellow “On” – Valve stopped in intermediate position
- Yellow “Blinking” – Monitor relay has tripped

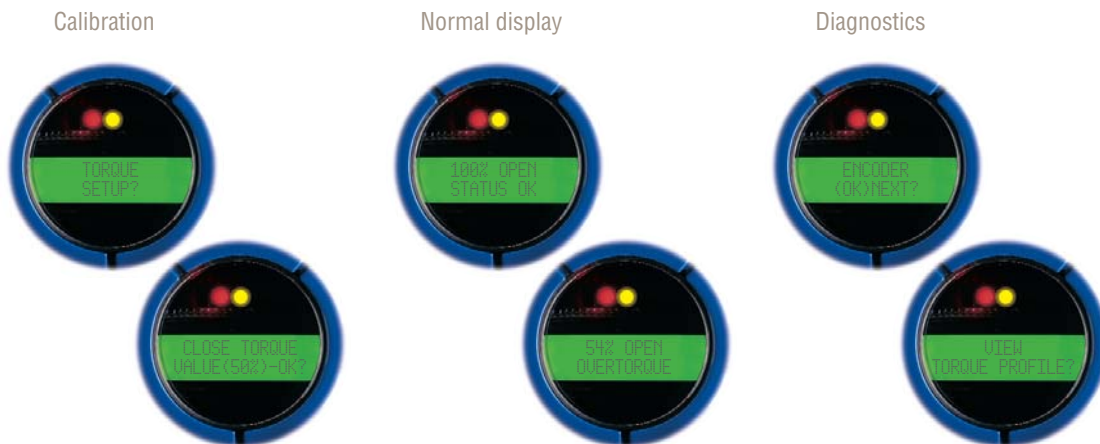

# Accutronix actuators stand up to the worst because they're the best through and through



## Separate termination chamber

The internal integrity of the controls components is assured because the components are double-sealed against outside elements. All connections to the actuator can be made, and calibration and diagnostics can be performed without exposing any internal component to the environment.

## Corrosion-resistant surfaces

Exposed surfaces of the housing and covers are primed and then electrostatically powder-coated for corrosion resistance.

## High-strength hardware

External hardware is carbon steel for strength, then hexavalent chromate coated, and finally coated with a durable polymer for a triple finish.



## Magnetically coupled Hall effect devices

Local control switches on the Accutronix MX control panel are magnetically coupled, solid state Hall effect devices. The use of solid state Hall effect devices for setup and configuration eliminates troublesome and fragile reed switches.

## Powertrain built for durability

Power transmission begins with a three-phase induction motor designed specifically for valve service. The motor is coupled to a hardened alloy steel worm that drives an aluminum-bronze worm gear. All shafts and sleeves are bearing-supported and are lubricated by extended-range synthetic oil designed for high-pressure gear service.



## Normal operations—even when conditions aren't

MX actuators have been tested and certified for demanding environmental and operational conditions, including temperature extremes, plant-induced vibration, electromagnetic interference, seismic susceptibility, XP hazardous areas, and highly corrosive atmospheres. Contactors, connectors, and motors deliver highly reliable operation even in extreme temperatures or electrical conditions, such as surges induced by lightning. Compliance with relevant world standards assures that Accutronix can be accurately specified for local conditions.



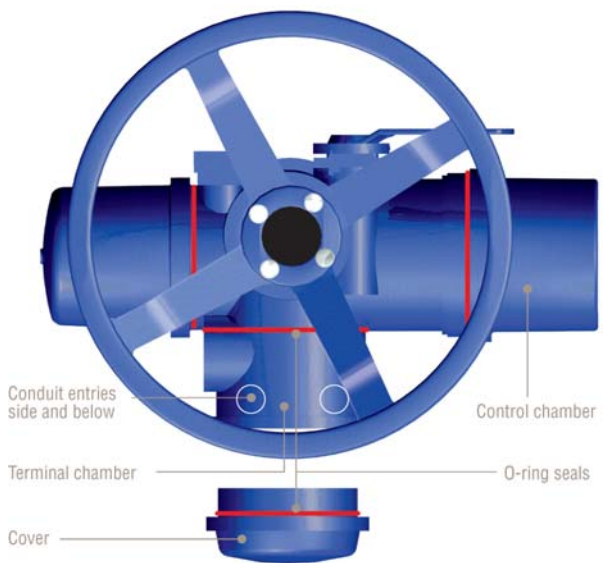
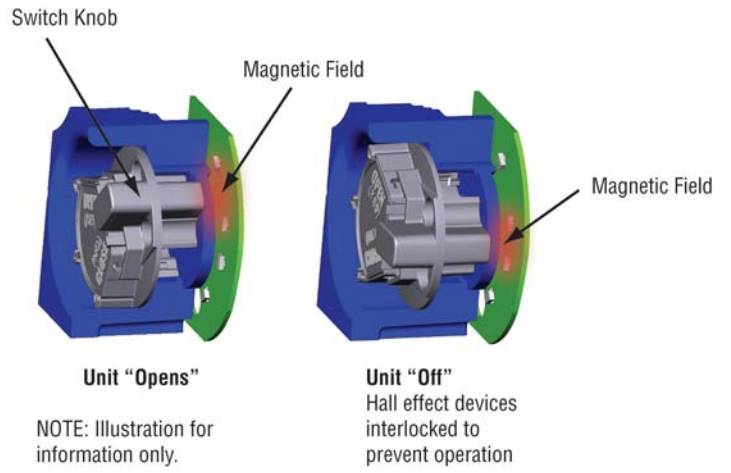

Double-sealed protection from dust and moisture

# Nothing exceeds Limitorque MX actuators for ease and compatibility with valves of all types

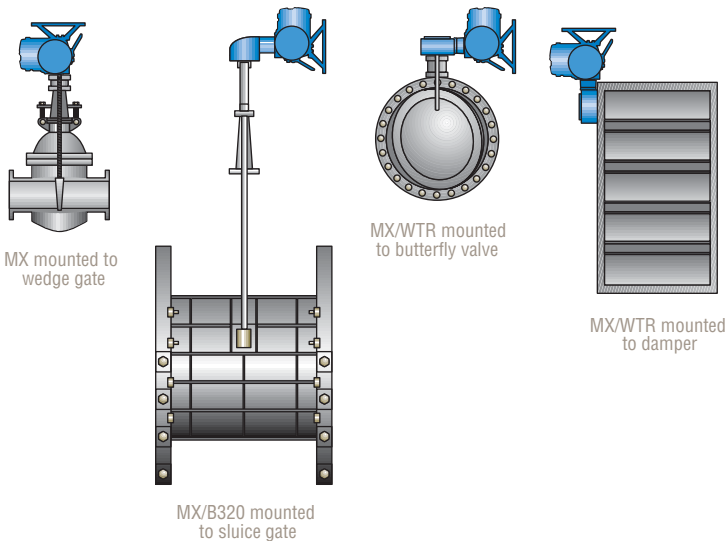

## Valves

Limitorque MX actuators have been designed to accommodate today's wide variety of valve designs and to meet international standards for valve and actuator interfaces, including ISO 5210 and MSS SP-102.

MX actuators are available in a wide variety of configurations to accommodate various applications and valve designs:

**Direct mounting** – The MX can be directly coupled with valves for torque-only applications. For thrust applications, a separate thrust base is used.

**MX/WTR** – The MX can be coupled to a PT, WTR or HBC worm gear reducer for operation of part-turn valves, such as butterflies, balls, plugs, and dampers. This combination provides an output torque capacity of up to 100,000 ft-lb/135,500 N m.

**MX/B320** – Rising stem valves may be operated by an Accutronix MX coupled to a B320 bevel gear reducer. Thrusts up to 325,000 lb/1,445 kN and torque up to 12,000 ft-lb/16,320 N m can be accommodated.

## Couplings

Thrust actuator drive couplings:

- Type A1 – Alloy bronze (thrust)
- Type A1E – Extended bronze nut

Torque-only actuator drive couplings:

- Type B4 – Standard steel bushing
- Type B4E – Extended steel bushing
- Type B1 – Large fixed-bore keyway steel bushing (ISO 5210)
- Type BL – Splined steel bushing for rising rotating stem valves

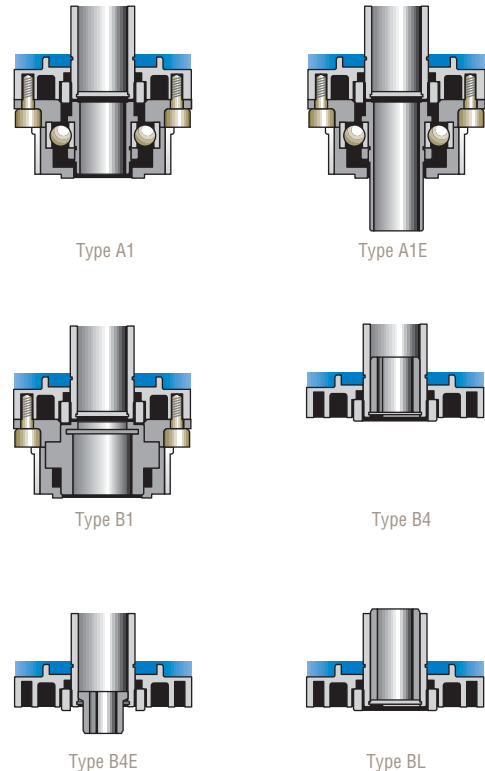
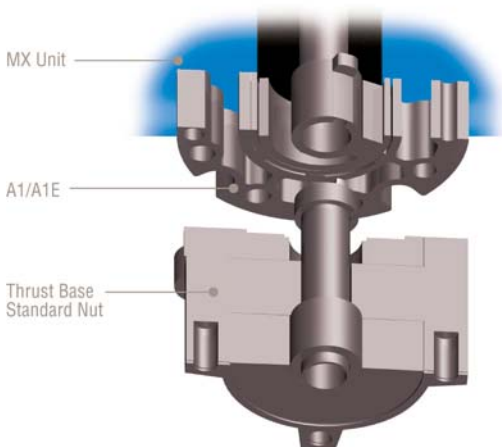

# Operational integrity— predictable performance every time

Three key enabling technologies enhance durability and overall performance.

## LimiGard supervisory actuator monitor

Enhanced reliability for optimal plant operations and reduced troubleshooting costs are the primary benefits of Limitorque's patented smart actuator monitor: LimiGard.

When LimiGard wiring diagrams are followed, LimiGard continually monitors the control relays, internal logic circuits, and external command signals, comparing them to reference conditions. This virtually eliminates the possibility that an actuator malfunction can occur without prompt detection and alarm communication. In the event of a malfunction, LimiGard takes over and supervises the actuator's response characteristics, maximizing safety and predictability. Fault Insertion Tests confirm this Fail/No-Action philosophy built into every MX actuator.

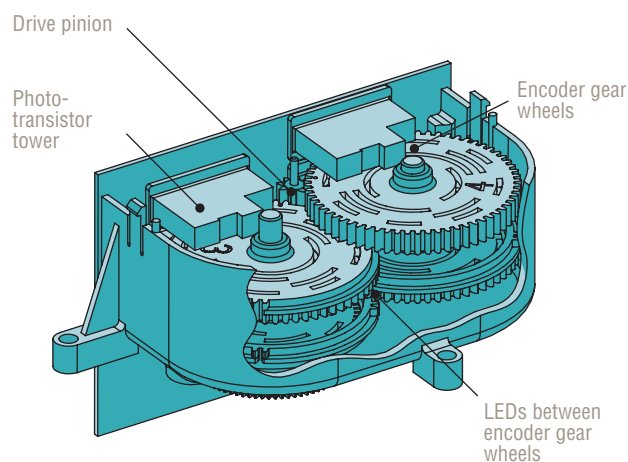
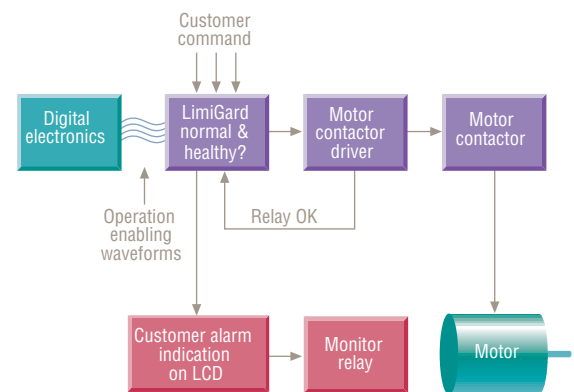

## Absolute position encoder

Limitorque's patented optical position encoder technology senses valve position for 100% repeatability in both hand-wheel and electric operation—with or without electrical power. This assures actuator accuracy when power is restored and eliminates the need for batteries or back-up power to track valve position during handwheel operation.

The absolute optical encoder incorporates 16 phototransistors that are switched on and off by a gear/wheel mechanism. Each combination of photo-transistor status represents a unique valve position.

## Torque sensor

MX actuators sense torque electronically for use in valve control, overload protection, and historical trending. Motor speed, voltage, and temperature are measured by a microprocessor that calculates torque. The measured torque value is compared with the calibrated value, and then used to tightly seat the valve, or protect the valve and actuator from an overload condition. Torque calibration is performed through the control panel.

Valve corrosion, changing process needs, and lack of routine maintenance can often increase the amount of torque required to operate a valve. Accutronix actuators are equipped with a torque profiling diagnostic capability that allows users to trend historic valve performance and to detect problems before they render a valve inoperable.

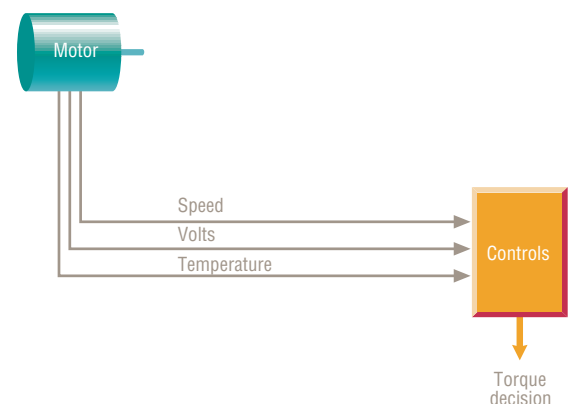

# Accutronix MX control, indication, and protection features

## Standard features

- **Direct-wired remote control** – Wiring flexibility includes the following standard alternatives to open-stop-close the actuator:
  - Four-wire – Valve can be opened, closed, or stopped.
  - Two-wire switched – Single open or closed contact; valve can be opened or closed, but not stopped.
  - Three-wire maintained – Two momentary contacts for self-maintained control. Valve can be opened or closed but not stopped in mid-travel.
  - Three-wire inching – Two “push-to-run” contacts; valve can be opened, closed, and stopped in mid-travel.
- **Monitor relay** – Provides an N/O and N/C contact representing “Actuator available for remote operation.”
- **Emergency Shutdown (ESD)** – A remote, external ESD signal may be applied to the actuator to move the valve to a predetermined user-configured shutdown position, overriding existing control signals.
- **Inhibit signals** – External signals may be used to inhibit actuator opening, closing, or both.
- **Control signals** – The control signal can be either 24 VDC or 125 VAC; it can be sourced from the actuator or customer supply.
- **Status contacts (4)** – May be set to represent valve open and closed positions (alternately, they may be configured to represent many other actuator conditions).

## Protection features

- **Autophase protection and correction** – Assures proper open/close directions and monitors and corrects phasing if connected improperly. Prevents operation if a phase is lost.
- **Jammed valve** – Automatically initiates a forward/reverse cycle to free jammed valves.
- **Instantaneous reversal protection** – Incorporates the proper time delay between the motor reversals to reduce current surges and extend contactor life.
- **Motor thermal protection** – A thermistor, placed within the motor, protects against overheating.

## Optional features

- **Alarm contacts** – Three additional unlatched contacts may be set to represent key actuator conditions, such as overtorque, thermal overload, power off, valve jamming, etc.

- **Two-speed timer** – A two-speed pulsing timer may be incorporated to support variable stroke times as configured by the user.
- **Analog Position Transmitter (APT)** – The APT is an internally powered, non-contacting valve position transmitter that provides a 4-20 mA signal proportional to valve position.
- **Analog Torque Transmitter (ATT)** – The ATT is a non-contacting, internally powered transmitter that provides a 4-20 mA signal that is proportional to actuator output torque.
- **Modutronic controller** – The Modutronic controller positions the valve in response to an external 4-20 mA command signal. It includes automatic pulsing mode to prevent overshoot at the set point. Parameters that may be set easily during configuration include proportional band, dead band, polarity, and action on loss of command signal.
- **Solid State Motor Reverser (SSMR)** – An SSMR is available when severe operating conditions demand continuous operation.
- **Arctic temperature** – Accutronix MX is the only commercial electronic valve actuator that is suitable for installation and operation in severely cold climates to  $-50^{\circ}\text{C}$  ( $-58^{\circ}\text{F}$ ). There is no need for external heat sources to supplement the internal power—the MX is predictable and reliable even in the most rugged applications.
- **Control Station (CSE)** – The CSE is a separate control station designed for the operation of inaccessible actuators. It is available with LEDs, Remote/Local and Open/Close selector switches. The CSE may be powered by the actuator internal supply, provided wire resistance and other external loads do not limit the available signal power presented to the Accutronix MX.
- **Isolation and Load Break Switches** – Isolation and Load Break Switches can be supplied for the incoming three-phase supply to the actuator. These may be coupled directly to the actuator for weatherproof (WP) applications only or supplied separately for mounting by user. The enclosure is suitable for weatherproof or temporary submersion service. An explosion-proof (XP) isolation switch is also available for user mounting. It is suitable for mounting with all MX actuators. Please contact factory for availability.
- **Negative Switching** – When remote control systems require the negative pole of the circuit supply to be switched to positive earth, an optional board is supplied.
- **Auxiliary Power Device (APD)** – The APD is designed such that, when power to the actuator is interrupted, the control operations of the Accutronix MX continue without interruption. It can supply continuous power for up to 24 hours, depending on options.

# Control up to 250 actuators with Limitorque flexible network protocols

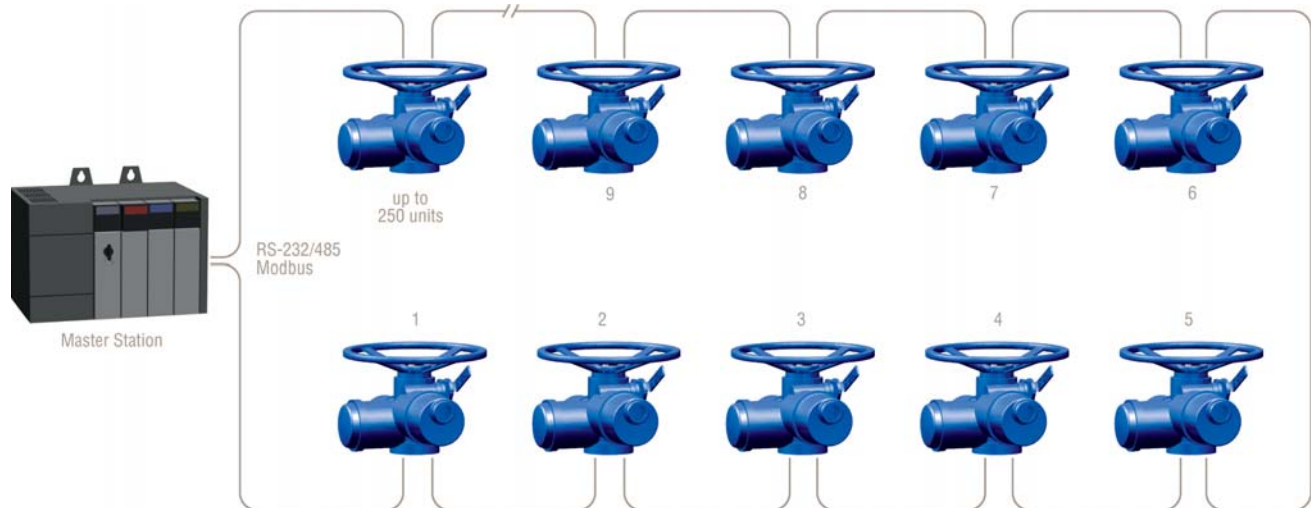

## Foundation Fieldbus H1 communication:

Limitorque's Foundation Fieldbus H1 interface for MX actuators uses an all-digital, serial, two-way communications system to permit a truly field-distributed control system.

Standard Function Blocks for Analog Output (AO), Digital Output (DO), and Digital Input (DI) are used to easily integrate the MX actuator into the plant control system. These standard Function Blocks permit a seamless interface to control and monitor the MX actuator with other field instrumentation for increased visibility and control of the plant processes.

### Other features of Foundation Fieldbus:

- Increased visibility of MX actuator status
- Reduced wiring and wire terminations
- Ease of configuration
- Open standard non-proprietary fieldbus protocol

## Profibus DP-V1 and PA communication:

Limitorque is the only electronic valve actuator manufacturer that provides the user with both Profibus options; the speed of PROFIBUS DP-V1 (up to 1.5 MB/s) and Profibus PA, for loop-powered, IS applications. Profibus is an international standard

(EN50170) and Accutronix MX actuators fitted with the PB DP-V1 and PA field unit device are immediately compliant with this standard and other PROFIBUS user organization certified devices.

## DDC-100 communication:

Limitorque's distributed digital control (DDC) valve-control network supports up to 250 actuators over a single twisted-pair cable using standard protocols. MX actuators and other devices can be accessed from a control room for integration with a distributed control system (DCS), programmable logic controller (PLC), or personal computer- (PC) based network. (Modbus)

## DDC-100 provides:

- Cost reduction – Multi-core cables are replaced with a single, shielded twisted-pair cable, providing significant savings in wire, conduit, installation, and maintenance costs. In addition, control room I/O equipment may be replaced by a single RS-232/485 connection.
- Reduced downtime – All information concerning the valve and actuator is accessed over the DDC-100 network. Problems can be detected, analyzed, and corrected before they disable a process.

- Proven connectivity – DDC-100's open standards-based connectivity interfaces with major DCS and PLC suppliers, including: Foxboro, Honeywell, Yokogawa, Allen-Bradley, GE, Westinghouse, Modicon, Fisher, and Siemens.

## DDC-100 specifications

### Master Station II (optional)

- Host interface – RS-232 or RS-485 (Modbus™ protocol)
- LED indicator for network status
- Configurable polling sequence priority
- Configurable bitmap to host
- Redundant RS-485 network ports
- High-level surge protection on network
- Logging port for maintenance PC

### Network

- Single-ended loop (consult factory)
- Modbus protocol
- High speed – up to 19.2 k baud

### Accutronix field units

- Open, stop, and close commands
- ESD and "GO TO POSITION" commands
- Actuator status and alarms messages
- Three discrete digital inputs and one analog input for user
- Two communication channels: surge-protected and isolated
- Accutronix control panel configuration

# MX Series Performance Ratings for Units 05–140

MX-05 through MX-40 (three-phase: 50 Hz/380, 400, and 415 Volt: 60 Hz/230, 380, 460, 575 Volt)

MX-85 through MX-140 (three-phase: 50 Hz/380\*, 400, and 415 Volt: 60 Hz/380, 460, 575 Volt)

\*380/50 multiply by 0.9

Output Speed (RPM)				MX-05		MX-10		MX-20		MX-40		MX-85		MX-140	
				Rated Output Torque											
60 Hz		50 Hz		ft-lb	N m	ft-lb	N m	ft-lb	N m	ft-lb	N m	ft-lb	N m	ft-lb	N m
18		15		55	75	125	170	225	305	440	597	N/A	N/A	N/A	N/A
26		22		55	75	125	170	225	305	440	597	850	1153	1500	2036
40		33		55	75	125	170	225	305	440	597	1225	1662	1700	2307
52		43		55	75	125	170	225	305	440	597	1150	1561	1600	2171
77		65		48	65	107	145	178	241	345	468	850	1153	1200	1628
100	131 <sup>1</sup>	84	110 <sup>1</sup>	39	53	89	121	148	201	286	388	600	814	739	1003
155	170 <sup>1</sup>	127	143 <sup>1</sup>	41	56	89	121	140	190	260	353	450	611	650	882
200		165		34	46	73	99	114	155	210	285	N/A	N/A	N/A	N/A

Note 1: MX-85 and MX-140

	lb.	kN	lb.	kN	lb.	kN	lb.	kN	lb.	kN	lb.	kN
Thrust Ratings (lb/kN)	8000	35	15000	66	25000	111	36000	160	50000	222	75000	333
	lb.	kg	lb.	kg	lb.	kg	lb.	kg	lb.	kg	lb.	kg
Weights (lb/kg)	52	24	65	29	109	49	133	60	250	114	300	136

## Maximum Stem Capacity

Type A Couplings	in.	mm	in.	mm	in.	mm	in.	mm	in.	mm	in.	mm
Type A1	1.26	32	1.57	40	2.36	60	2.64	67	3.50	88	3.50	88
Type A1E (Extended Nut)	1.26	32	1.57	40	2.36	60	2.64	67	3.50	88	3.50	88
Type B Couplings (Torque Only) <sup>2</sup>	in.	mm	in.	mm	in.	mm	in.	mm	in.	mm	in.	mm
Type B4	1	25.4	1.25	30	1.94	50	2.2	55	2.88	73	2.88	73
Type B4E (Extended)	0.75	19	0.91	22	1.56	41	1.78	46	2.25	57	2.25	57
Type B1 (Fixed Bore) <sup>3</sup>	N/A	42	N/A	42	N/A	60	N/A	60	N/A	N/A	N/A	N/A
Type BL (Splined)	6 & 38 Splines		6 & 38 Splines		6 & 36 Splines		6 Splines		N/A	N/A	N/A	N/A
Maximum Bore and Keyway	in.	mm	in.	mm	in.	mm	in.	mm	in.	mm	in.	mm
Maximum Bore (B4)	1	25	1.25	30	1.94	50	2.2	55	2.88	73	2.88	73
Maximum Keyway	¼ sq.	8 x 7	¼ sq.	10 x 8	½ x ¾	14 x 9	½ x ¾	16 x 10	¾ x ½	20 x 12	¾ x ½	20 x 12
Maximum Bore (B4E)	.75	18	0.91	22	1.56	41	1.78	46	2.25	56	2.25	56
Maximum Keyway	⅜ sq.	6 x 6	¼ sq.	8 x 7	¾ sq.	12 x 8	½ x ¾	14 x 9	½ x ¾	16 x 10	½ x ¾	16 x 10

Note 2: Maximum bores for Type B couplings may require rectangular keys.

Note 3: Available in ISO base only.

	MX-05	MX-10	MX-20	MX-40	MX-85	MX-140
Mounting Base (MSS SP-102/ISO 5210)	FA10/F10	FA10/F10	FA14/F14	FA14/F14	FA16/F16	FA25/F25
Handwheel Ratio (STD/Optional)	Direct	Direct/8:1	Direct/12:1	Direct/24:1	16/48	16/48
Side-Mounted Handwheel Efficiencies	N/A	52%	54%	51%	53%/51% <sup>4</sup>	53%/51% <sup>4</sup>

Note 4: Efficiencies for MX-85 and 140 are 51% with SGA and 53% without SGA.

## MX Handwheel Rimpull

Unit/ Mounting	Handwheel Diameter (in.)	Gear Ratio	Rated Torque ft-lb	Efficiency	Rimpull at Rated Torque (lb.)	Output Torque at 20 lb. Rimpull	Output Torque at 40 lb. Rimpull	Output Torque at 60 lb. Rimpull	Output Torque at 80 lb. Rimpull
MX-05 Top	12	1	55	0.88	125	9	18	26	35
MX-05 Top	18	1	55	0.88	83	13	26	40	53
MX-10 Top	18	1	125	0.88	189	13	26	40	53
MX-10 Side	12	8	125	0.52	60	42	83	125	166
MX-20 Top	24	1	225	0.88	256	18	35	53	70
MX-20 Side	12	12	225	0.54	69	65	130	194	259
MX-40 Top	24	1	440	0.88	500	18	35	53	70
MX-40 Side	12	24	440	0.51	72	122	245	367	490
MX-85/140 w/o SGA	18	16	600	0.53	88	127	254	382	508
MX-85/140 w/SGA	18	48	1574	0.51	86	367	734	1101	1469

# MX specifications

Limitorque MX electric valve actuators are designed for the operation of ON-OFF and modulating valves. They include a three-phase electric motor, worm gear reduction, absolute encoder, electronic torque sensor, reversing motor contactor, electronic control, protection and monitoring package, handwheel for manual operation, valve interface bushing, 32-character LCD, and local control switches—all contained in an enclosure sealed to NEMA 4, 4X, 6, and IP68. Explosion-proof (XP) enclosures can also be provided when required. All MX actuators comply with applicable European Directives and exhibit the CE mark.

## Gear drive

- Bearing-supported worm gear reduction, lubricated with an extended-life synthetic oil.

## Motor

- Three-phase squirrel cage induction type, designed for valve actuator service. Supplied with a solid state thermistor to prevent damage due to temperature overloads.
- Available as 50 Hz/380, 400, 415, or 440 Volts and 60 Hz/208, 230, 380, 460, or 575 Volts.
- Bolt-on design with plug-in connector allows easy removal.

## Controls

- Power and logic circuit boards, a control transformer, and fuses are mounted to a steel plate that is attached in the control compartment with captive screws. Plug-in connectors allow for easy removal.
- Reversing contactor is interlocked to prevent simultaneous energizing of the open and closed coils and supplied with control logic to extend contactor life by inhibiting high current surges caused by rapid motor reversals.
- Phase correction circuit detects and corrects motor rotation faults caused by incorrect site wiring and also prevents operation of the motor due to a loss of phase.
- Control transformer powers actuator controls and minimal external loads from the site's three-phase power supply. It includes vacuum-impregnated coils for moisture resistance and dual fuse protection.
- Internal 110 VAC and 24 VDC power supplies for remote control functions are fuse protected.
- Terminals for auxiliary 24 VDC supply provide the ability to externally power the electronic control package and LCD display without AC power.
- LimiGard is protection circuitry that continually monitors motor controls, internal logic circuits, and external command signals to all but eliminate the possibility of actuator malfunction due to internal component failures or erratic command signals.

## Control panel (local control and indication)

- 32-character LCD displays valve position (0–100%), current actuator status, and provides dialog for calibration. Available languages include English, Spanish, German, French, Italian, and Portuguese.
- Green, red, and yellow LEDs for local position indication; LOCAL-STOP-REMOTE and OPEN-CLOSE switches provide local valve control and are magnetically coupled to solid state Hall effect devices under the controls cover for environmental security.
- LOCAL-STOP-REMOTE switch is padlockable in each position.
- OPEN-CLOSE switch is spring-return-to-center and may be configured for maintained or push-to-run (inching) control.

## Remote control

- Remote control can be configured using two, three, or four wires for open-stop-close control.
- Connections are also supplied for ESD (Emergency Shutdown) and inhibit movement commands. The ESD signal will override existing control signal and send the valve to a pre-set position.

## Remote indication

- Four latched contacts (configurable as N/O or N/C and for any valve position) provide remote indication of valve position.
- Alternately, the contacts may be configured to represent other actuator status: overtorque, motor thermal overload, power off, manual operation, local selected, etc.

## Monitor relay

- Will de-energize when the actuator is not available for remote operation. Both N/O and N/C contacts are included and are rated 250 VAC/30 VDC, 5 amps.

## Calibration

- Simple, non-intrusive calibration of all actuator settings through the control panel. A password may be user-configured to prevent unauthorized changes. No tools are required.

## Position sensing

- 15-bit, optical, 100% repeatable absolute encoder for measurement of valve position. Open and closed positions are stored in permanent, non-volatile memory. The encoder measures valve movement at all times, including both motor and handwheel operation. Position resolution is better than 0.1% for valves requiring 50 turns or more. Maximum output turns are 1350 drive sleeve turns for units >25 RPM.

## Torque sensing

- A microprocessor calculates output torque from motor speed, voltage, and temperature. Torque limit may be set from 40–100% of rating in 1% increments. A boost circuit is included to prevent torque trip during initial valve unseating and in cold climates. A “Jammed Valve Protection” feature, with automatic retry sequence, is included to de-energize the motor if the output torque requirement exceeds boost torque.

## Terminal compartment

- Separately sealed terminal chamber for connection of site wiring protects actuator components from the environment. Internal sealing is suitable for NEMA 4, 6, and IP68. Includes three power terminals, a ground screw, and 52 control screw-type terminals.

## Conduit entries

- Three conduit entries, available as NPT, mm, or PG.

## External corrosion protection

- Primed using high solids epoxy and powder top-coated, royal blue color with a DFT of 1–3 mils. The coating is suitable for an ASTM B117 salt spray test of 1500 hours.
- External fasteners are high-strength carbon steel, hexavalent chromate-coated, and top-coated with a high-strength, high-endurance polymer coating.

## Handwheel

- Handwheel with padlockable, manual declutch lever is provided for manual operation.

**Wiring**

- All internal wiring is flame resistant, rated -40°C to 105°C (-40°F to 221°F), and is UL listed.

**Ambient working temperature**

- The normal operating temperature range is from -30°C to 70°C (-22°F to 158°F).

**Valve interface**

- Mounting base conforms to MSS SP-102 or ISO 5210/1/2/3 as required. Steel torque bushings (type B) and bronze thrust nuts (type A) are removable for machining. Refer to rating chart on page 16 for a listing of couplings available.

**Design life**

- One million drive sleeve turns.

**Diagnostic features**

- Diagnostic facilities are displayed on the LCD by accessing the diagnostic menu. It includes: motor data (voltage, current, phase rotation, and temperature), hardware status, identification (tag, serial order, and software revision), torque profile (comparison of last torque to baseline), and operations log (total turns, contactor operations, valve stroke time, and handwheel operations).

**Factory test**

- Factory testing verifies rated output torque, output speed, motor performance, handwheel operation, local control, control power supply, and control features. A report confirming successful completion of testing is included within the actuator.

**Testing summary**

**Endurance** – 50 million collective drive sleeve turns of endurance testing.

<b>Applicable emissions standards</b>	EN50011:1998
Radiated emissions	EN55011:1998 & FCC Part 15, subpart J
Conducted emissions	EN55011:1998 & FCC Part 15, subpart J
<b>Applicable immunity standards</b>	IEC EN 61000-6-1:2001
ESD	IEC61000-4-1:1995
Radiated RF immunity	IEC61000-4-3:1995
Fast Transients/Burst	IEC61000-4-4:1995
Voltage Surges	IEC61000-4-5:1995
Conducted RF immunity	IEC61000-4-6:1996
Magnetic Field immunity	IEC61000-4-8:1993
Voltage Dips and Interrupts	IEC61000-4-11:1994

**Vibration and seismic** – Per MIL-STD-167 and IEC68-2-6.

Vibration consists of 5-200-5 Hz sweeps at 0.75 g acceleration in 3 axes and 2-35 Hz at 1.0 g acceleration in 3 axes. Seismic is 5.0 g acceleration from 3.5-35 Hz in 3 axes.

**Drop test** – D3332-88, method A.

**Submersion** – NEMA 6 (6 ft.–30 min.), IEC529, IP68 (7 m–48 hrs.), Limitorque spec. (20 ft.–24 hr.).

**Temperature extremes with humidity** – Confirm function of motor, controls, and output torque at -30°C (-22°F) for 72 hours continuous, 70°C (158°F) dry heat for 16 hours continuous and 70°C (158°F) damp heat for 72 hours continuous.

**Airborne sound** – 74 dB (at 200 RPMs) per grade A noise requirement of MIL-STD-740 and ANSI/ISA-S82.01-1994 (Harmonized std. to IEC 1010-1).

**Di-electric** – Motor per NEMA MG1-12.02 and .03 with leakage of less than 10 mA. Control terminals per IEC-1131-2 and CSA C22.2 with check against physical breakdown.

**Salt spray** – 1500-hour test per ASTM B117-1985.

**AWWA C540-87** – “Standard For Power Actuating Devices For Valves and Sluice Gates” – 5,000 cycles with confirmation of specified torque and position accuracy.

**Non-hazardous certification options**

- FM – NEMA 3, 4, 4X and 6.
- CSA – Type 3, 4, and 6.
- IEC – IP 68 to 7 m for 48 hours.

**Explosionproof certification options**

- FM – Class 1, Division 1, Group B, C, and D. Class II/III, Division 1, Group E, F, and G.
- CSA – Class 1, Division 1, Group C and D. Class II/III, Division 1, Group E, F, and G.
- ATEX – EEx d IIB T4 ATEX II 2 G, CENELEC Norm EN50014 and EN50018
  - EEx d IIC T4 ATEX II 2 G, CENELEC Norm EN50014 and EN50018
  - EEx de IIB T4 ATEX II 2 G, Increased Safety, CENELEC Norm EN50014, EN50018, EN50019
  - EEx de IIC T4 ATEX II 2 G, Increased Safety, CENELEC Norm EN50014, EN50018, EN50019
- SAA – Ex d & Ex de IIC and Ex d & Ex de IIB.

## Options

### Stainless Steel Hardware

#### APT (Analog Position Transmitter)

- 4-20 mA output signal proportional to valve position.

#### ATT (Analog Torque Transmitter)

- 4-20 mA output signal proportional to output torque.

#### Modutronic

- Alters valve position in proportion to a 4-20 mA command signal. Proportional band, deadband, signal polarity, and fail position are all configured through the control panel.

#### SSMR (Solid State Motor Reverser)

- The MX can be ordered with an SSMR package extending operational duty for modulating applications up to 1200 starts per hour.

#### Two-speed timer

- Pulses motor to achieve a longer overall stroking time. Configurable for both directions of travel and for any portion of the valve stroke.

#### Arctic climates

- A severe cold temperature option is available for climates from -30°C to -50°C (-22°F to -58°F).

#### Alarm relays

- Two N/O and one N/C output contacts, configurable to represent any actuator status (valve position, torque overload, etc.).

#### Negative switching

- When remote control systems require the negative pole of the circuit supply to be switched to positive earth, an optional board is supplied.

#### APD (Auxiliary Power Device)

- The APD is designed such that when power to the actuator is interrupted, the controls operation of the Accutronix MX continues without interruption. It can supply continuous power for up to 24 hours, depending on options.

## Network protocols

### DDC-100

- The DDC-100 control system provides the ability to connect up to 250 actuators over a single twisted-pair cable. The communication network employs Modbus protocol on an RS-485 network, is redundant, and may be managed from various control room devices, including pushbuttons, PLC, DCS, or PC. Actuator commands that may be initiated over the network include open, close, stop, ESD, and “Move To” position. Actuator network messages include valve position and status, alarms, configuration, and diagnostic data.

### Foundation Fieldbus H1

Accutronix MX actuators can be fitted with the FF-Hi field unit connected to a Foundation Fieldbus Hi network. This device is certified for interoperability by the Fieldbus Foundation and employs two-wire technology.

#### The user layer in each device contains:

- One resource block
- One transducer block
- Function blocks for (1) AI, (4) DI, (2) DO, (1) AO with multiple channels available for use with each block.

#### Network specifications

- Point-to-point topology, bus with spurs topology, daisy chain topology, tree topology, or a combination of these four topologies.
- Fieldbus protocol IEC 1158-2 and ANSI/ISA-S50.02, Part 2-1992, Fieldbus Standard for Use in Industrial Control Systems Part 2: Physical Layer Specification and Service Definition.
- High speed – up to 31.25 kbits/s communications.

#### MX FF-H1 device specifications

- Device descriptions are available online at [www.fieldbus.org](http://www.fieldbus.org).

### Profibus DP-V1 and PA

Limitorque is the only electronic valve actuator manufacturer that provides the user with both Profibus options; the speed of PROFIBUS-DP V1 (up to 1.5 MB/s) and Profibus PA, for loop-powered, IS applications. Profibus is an international standard (EN 50170) and Accutronix MX actuators fitted with PB DP-V1 and PA field unit device are immediately compliant with this standard and other PROFIBUS user organization certified devices.

## **Australian Distributor for Limitorque**

Acrodyne Pty Ltd  
14/11 Havelock Road  
Bayswater, Victoria 3153  
Australia  
Phone 03-8727-7800  
Fax 03-9729-8699